

1. Report No. XXXXXX		2. Government Accession No.	3. Recipient's Catalog No.
4. Title and Subtitle Evaluation of Continuity Detail for Precast Prestressed Girders		5. Report Date December 2010	
		6. Performing Organization Code	
7. Author(s) Ayman M. Okeil, Ph.D., P.E. Steve Cai, Ph.D., P.E. Veeravenkata Chebole Tanvir Hossain, M.S.		8. Performing Organization Report No.	
9. Performing Organization Name and Address Department of Civil and Environmental Engineering Louisiana State University Baton Rouge, LA 70803		10. Work Unit No.	
		11. Contract or Grant No. LTRC Project Number: 08-1ST State Project Number: 736-99-1513	
12. Sponsoring Agency Name and Address Louisiana Department of Transportation and Development P.O. Box 94245 Baton Rouge, LA 70804-9245		13. Type of Report and Period Covered Final Report March 2008 – September 2010	
		14. Sponsoring Agency Code	
15. Supplementary Notes XXXXXX			
16. Abstract <p>The construction of highway bridges using precast prestressed concrete (PSC) girders is considered one of the most economical construction alternatives because of the advantages they offer (e.g. reducing formwork and rapid construction). Constructing multi-simple span bridge is an easy alternative for precast PSC girder bridges. However, the existence of expansion joints often leads to a host of problems in their vicinity due to drainage leaks and debris accumulation. The maintenance of expansion joints is, therefore, an activity that bridge owners would rather avoid by eliminating these joints. The connection between precast elements needs to be capable of resisting the forces for which they are designed. Several continuity details have been used over the years for slab-on-girder bridges with the goal of avoiding the aforementioned maintenance issues and reaping the benefits of continuity without the drawbacks of introducing it in large structures such as bridges (e.g. thermal movements). A new continuity detail is adopted in the John James Audubon Bridge that differs from the current standard detail in Louisiana. The detail is based on the recommendation of the National Cooperative Highway Research Program (NCHRP) Project 12-53 (1).</p> <p>A 96-channel monitoring system was installed to provide information that can be used to assess the performance of the continuity detail. Embedded and surface-mounted sensors of different types were installed to measure strains, temperatures, rotations, and gap openings in critical locations in the monitored segment. Data from about 24 months of monitoring was collected. The data, its processing, and interpretation are presented in this report. Analyses based on NCHRP Project 12-53 models and finite element models were also conducted to further understand the behavior of the new detail. Results from the analyses were also used to recommend girder age at continuity to meet prespecified design criteria. A live load test was also conducted to assess the performance of the new detail.</p> <p>Recommendations based on the findings of the project are drawn. It can be said that the continuity detail is capable of transferring forces between girder ends. However, girder ends may be subjected to high localized strains, especially due to thermal variation, which can cause cracking. Such cracks are detrimental to the shear strength of PSC girders. Therefore, thermal gradients need to be considered in the design of this detail.</p>			
17. Key Words prestressed concrete; creep; continuous structures; bridges, live load			18. Distribution Statement Unrestricted.
19. Security Classification (of this report) N/A	20. Security Classification (of this page) N/A	21. No. of Pages 182	22. Price N/A

Project Review Committee

Each research project will have an advisory committee appointed by the LTRC Director. The Project Review Committee is responsible for assisting the LTRC Administrator or Manager in the development of acceptable research problem statements, requests for proposals, review of research proposals, oversight of approved research projects, and implementation of findings.

LTRC appreciates the dedication of the following Project Review Committee Members in guiding this research study to fruition.

LTRC Administrator/ Manager
Walid Alaywan, MSCE, P.E.
Senior Structures Research Engineer

Members

XXX XXXXX, XXXXXXXXXXXX
XXX XXXXX, XXXXXXXXXXXX
XXX XXXXX, XXXXXXXXXXXX
XXX XXXXX, XXXXXXXXXXXX
XXX XXXXX, XXXXXXXXXXXX
XXX XXXXX, XXXXXXXXXXXX
XXX XXXXX, XXXXXXXXXXXX
XXX XXXXX, XXXXXXXXXXXX
XXX XXXXX, XXXXXXXXXXXX

Directorate Implementation Sponsor
William B. Temple
DOTD Chief Engineer

Evaluation of Continuity Detail for Precast Prestressed Girders

by

Ayman M. Okeil, Ph.D., P.E.
Associate Professor

Steve Cai, Ph.D., P.E.
Professor

Tanvir Hossain, M.S.
Research Assistant

Department of Civil and Environmental Engineering
3513-D Patrick F. Taylor Hall
Louisiana State University
Baton Rouge, LA 70803

LTRC Project No. 08-1ST
State Project No. 736-99-1513

Conducted for

Louisiana Department of Transportation and Development
Louisiana Transportation Research Center

The contents of this report reflect the views of the author/principal investigator who is responsible for the facts and the accuracy of the data presented herein. The contents do not necessarily reflect the views or policies of the Louisiana Department of Transportation and Development or the Louisiana Transportation Research Center. This report does not constitute a standard, specification, or regulation.

December 2010

DRAFT

ABSTRACT

The construction of highway bridges using precast prestressed concrete (PSC) girders is considered one of the most economical construction alternatives because of the advantages they offer (e.g. reducing formwork and rapid construction). Constructing multi-simple span bridge is an easy alternative for precast PSC girder bridges. However, the existence of expansion joints often leads to a host of problems in their vicinity due to drainage leaks and debris accumulation. The maintenance of expansion joints is, therefore, an activity that bridge owners would rather avoid by eliminating these joints. The connection between precast elements needs to be capable of resisting the forces for which they are designed. Several continuity details have been used over the years for slab-on-girder bridges with the goal of avoiding the aforementioned maintenance issues and reaping the benefits of continuity without the drawbacks of introducing it in large structures such as bridges (e.g. thermal movements). A new continuity detail is adopted in the John James Audubon Bridge that differs from the current standard detail in Louisiana. The detail is based on the recommendation of the National Cooperative Highway Research Program (NCHRP) Project 12-53 (1).

A 96-channel monitoring system was installed to provide information that can be used to assess the performance of the continuity detail. Embedded and surface-mounted sensors of different types were installed to measure strains, temperatures, rotations, and gap openings in critical locations in the monitored segment. Data from about 24 months of monitoring was collected. The data, its processing, and interpretation are presented in this report. Analyses based on NCHRP Project 12-53 models and finite element models were also conducted to further understand the behavior of the new detail. Results from the analyses were also used to recommend girder age at continuity to meet prespecified design criteria. A live load test was also conducted to assess the performance of the new detail.

Recommendations based on the findings of the project are drawn. It can be said that the continuity detail is capable of transferring forces between girder ends. However, girder ends may be subjected to high localized strains, especially due to thermal variation, which can cause cracking. Such cracks are detrimental to the shear strength of PSC girders. Therefore, thermal gradients need to be considered in the design of this detail.

ACKNOWLEDGMENTS

The authors gratefully acknowledged the financial support provided by the Louisiana Transportation Research Center (LTRC Project No. 08-1ST) and Louisiana Department of Transportation and Development (State Project No. 736-99-1513).

The authors also acknowledge the assistance of the graduate students Tanvir Hossain and Veeravenkata Chebole who helped in some of the analysis reported herein. Many other graduate students who helped with the installation and live load testing including Yilmaz Bingol, Miao Xia, Xuan Kong, Archana Nair, and Fenghong Fan.

The authors would also like to thank Paul Fossier (DOTD) for initiating the idea behind this project and for providing information pertinent to the project throughout its execution. The support from the DOTD's Structures and Facilities Maintenance Administration (Gill Gautreau and Steven Sibley) is greatly appreciated. On site support from Louisiana TIMED Managers (Jim Wiley and Wayne Marchand) was essential for the success of this project. Support from LTRC Concrete Research Laboratory (Randy Young) with the testing of concrete specimens is greatly appreciated. Finally, the assistance from contractors of the bridge and the monitoring system (G.J Shexnayder and Zach Jopling – Boh Brothers, Jeremy Adkins and Eric Hebert – Dunham Price, Jeff Schultz, Scott Aschermann, and Jesse Grimson – Bridge Diagnostics, Inc.) is greatly acknowledged.

Special thanks are due to Walid Alaywan (LTRC), Senior Structures Research Engineer for his support of this research.

IMPLEMENTATION STATEMENT

New bridges whether designed by LA-DOTD engineers or consulting firms can directly and immediately benefit from this study. The results from this study include providing engineers with essential information for a successful design using the new detail. These can be summarized as follows:

1. The study highlights the importance of considering the effect of thermal variations on bridges employing this detail. Most studies on this and similar continuity details focused on other factors and did not quantify or discuss the effects of thermal variations, which was shown to be a dominant factor for the new detail.
2. It also brings to the attention of the designer that one girder age criterion such as the 90-day limit in NCHRP 519 may not be appropriate for all bridge configurations. Therefore, detailed analyses need to be conducted such that appropriate girder ages are used to ensure the avoidance of adverse effects of high positive restraint moments; i.e. diaphragm or girder end cracking.
3. The effects of live loads on the detail are small when it comes to the positive moment action, and therefore, may be ignored. The effect of live loads on the negative moment action is considerable and needs to be considered.
4. Simpler details that eliminate expansion joints by keeping the deck continuous over simply-supported girders; i.e. partial integration, expedite the construction of bridges and reduce the potential for damage caused by leaks through expansion joints or high positive restraint moments. Therefore, such details should be the default continuity detail in LA-DOTD projects.

TABLE OF CONTENTS

ABSTRACT.....	III
ACKNOWLEDGMENTS	V
IMPLEMENTATION STATEMENT	VI
TABLE OF CONTENTS.....	VII
LIST OF TABLES	XI
LIST OF FIGURES	XIII
INTRODUCTION	1
Continuity in Precast Prestressed Girder Bridges.....	1
Historic Background	4
NCHRP Projects 12-29, 12-53 and Related Research	5
Louisiana Research on Bridge Diaphragms.....	8
Calculation of Restraint Moment.....	9
Research Needs.....	10
OBJECTIVE	13
SCOPE	15
METHODOLOGY	17
Structural Health Monitoring.....	17
Description of Monitored Bridge.....	17
Material Properties and Fabrication Details	21
Instrumentation Plan	22
Data Processing.....	28
Continuity Assessment.....	32
Analytical Model	33
RESTRAINT Program (NCHRP Project 12-53)	33
Limitations of RESTRAINT	34
Modified Program mRESTRAINT	34
Parametric Study	35
Methodology for Establishing Age of Continuity	36
Finite Element Models.....	40
Single-line Girder Model	40

Global Bridge Model	44
Joint Model	45
Live Load Test	47
Truck Description	47
Static Load Tests	47
Additional Sensors for Dynamic Tests	51
Dynamic Load Tests	52
Temperature Effect	55
Sample sensor reading	56
DISCUSSION OF RESULTS	59
Structural Health Monitoring Data	59
Temperature Data	59
Strains in Hairpin Bars	62
Relative Movement between Bottom Flanges in Adjacent Spans	66
Differential Shrinkage between Deck and Girder Concrete	67
Rotation of Girder Ends in Adjacent Spans	69
Creep of Girders During Curing Period	71
Deck Cracking	73
Results from Parametric Study using mRESTRAINT	74
Results from Live Load Test	79
Feedback from Contractors	82
SUMMARY AND CONCLUSIONS	83
Summary	83
Conclusions	83
RECOMMENDATIONS	85
ACRONYMS, ABBREVIATIONS, & SYMBOLS	87
REFERENCES	90
APPENDIX A	93
APPENDIX B	107
Major Modifications to RESTRAINT Program	107
APPENDIX C	111
APPENDIX D	133
APPENDIX E	137
APPENDIX F	156
Elements used in thermal analyses	156

Elements used in stress analyses.....	157
APPENDIX G.....	161

DRAFT

LIST OF TABLES

Table 1 Mechanical properties for concrete.....	21
Table 2 Technical specifications of employed sensors.....	24
Table 3 Types and number of sensors employed in this study.....	24
Table 4 Technical specifications of employed sensors.....	36
Table 5 Description of static live load positions.....	49
Table 6 Technical specifications of employed sensors.....	67
Table 7 Minimum girder age at continuity (in days) that meets acceptable restraint moment levels, $M_{r,a}$, (7500 days – diaphragm cracking moment).....	75
Table 8 Minimum girder age at continuity (in days) that meets acceptable restraint moment levels, $M_{r,a}$, (20000 days – diaphragm cracking moment).....	76
Table 9 Minimum girder age at continuity (in days) that meets acceptable restraint moment levels, $M_{r,a}$, (7500 days – PSC girder cracking moment).....	77
Table 10 Minimum girder age at continuity (in days) that meets acceptable restraint moment levels, $M_{r,a}$, (20000 days – PSC girder cracking moment).....	78
Table A-1 Installed sensor details.....	100
Table A-1 (continued) Installed sensor details.....	101

LIST OF FIGURES

Figure 1 Typical continuity conditions in precast PSC girder bridges: (a) simply-supported, (b) fully continuous, (c) partially continuous. (2).....	2
Figure 2 Development of positive moment in bridge connections with continuity diaphragm.....	3
Figure 3 Bond breaker at girder ends.....	4
Figure 4 Alternatives for positive moment reinforcement (I).....	7
Figure 5 Bridge #2 chosen by LA-DOTD for monitoring the continuity detail.....	19
Figure 6 Main dimensions of monitored Bridge #2.....	20
Figure 7 Stress-strain relationship for prestressing strands.....	22
Figure 8 Antisymmetry of Bridge #2 allowed monitoring only one of the continuity details.....	25
Figure 9 Instrumentation Plan for structural health monitoring of positive moment continuity detail in Bridge #2.....	26
Figure 10 Sectional locations of embedded and surface-mounted sensors in Bridge #2.....	27
Figure 11 Communication between the datalogger (station) and the server.....	28
Figure 12 Removal of outliers from raw data (sensor #22 – VW on G1 (bottom) at Bent 24 in Span 23).....	29
Figure 13 Temperature correction of sensors #88(ES) and #92(EC) in G3 (bottom) at Midspan 24).....	31
Figure 14 Joined data record for tiltmeter (TM) at G1 in Spans 23 and 24.....	32
Figure 15 One set of results showing the effect of age of continuity on M_r	36
Figure 16 Transfer length model used in estimating M_{cr} at girder ends (Nilson 1987).....	38
Figure 17 Determining girder age that achieves prespecified M_r criteria.....	39
Figure 18 Meshing of cross section.....	41
Figure 19 Centerline model for Girder G3.....	42
Figure 20 Global model for Bridge #2.....	44
Figure 21 Creation of detailed joint model.....	46
Figure 22 Load test truck positions (distance with reference to middle of rear drive axle – see Figure D-2).....	50
Figure 23 Marking the bridge deck at truck positions for static live load test.....	51
Figure 24 Actual Trucks #1 and #2 in position for two of the nine static load positions.....	51
Figure 25 Truck paths for the dynamic load tests.....	54
Figure 26 Temperature increase during the time of conducting static load tests.....	55
Figure 27 Sample sensor reading during static live load testing (Sensor #50 – G3, Span 23, hairpin bar).....	57
Figure 28 Temperature readings in deck, top and bottom girder flanges.....	61
Figure 29 Sunlight hitting the bottom flange of G5 while the top flange is shaded by the overhang.....	62

Figure 30 Temperature gradient (Girder G3 in the middle of Span 24).	62
Figure 31 Strains in hairpin bars at both sides of continuity diaphragm.	64
Figure 32 Observed crack at bottom flange of Girder G3 – Span 24.	65
Figure 33 Surface-mounted VW strains at bottom flanges on both sides of continuity diaphragm (Girders G1, G3, and G5).	65
Figure 34 Gapmeter displacements for Girders G1, G3, and G5.	67
Figure 35 Strain records in deck and top flange at Girder G3, G4, and G5 locations.	69
Figure 36 Rotation of girder ends (G1, G3, and G5).	70
Figure 37 Schematic of girder end rotations.	71
Figure 38 Early strains in Span 24 Girders G1, G3, and G5 while curing in casting yard.	72
Figure 39 Observed deck cracks over continuity detail.	73
Figure 40 Contours of vertical displacement (Case P5).	79
Figure 41 Strains in hairpin bars showing positive values for faraway load cases.	81
Figure A-1 Strandmeters installed on hairpin bars at girder ends.	93
Figure A-2 Sisterbar installed next to a prestressing strand at midspan.	93
Figure A-3 Strandmeters installed on reinforcing bars in deck over continuity diaphragm.	94
Figure A-4 Sisterbars installed next to reinforcing bars in deck over continuity diaphragm.	94
Figure A-5 Surface-mounted sensors (vibrating wire gages and tiltmeters) at girder ends.	95
Figure A-6 Gap meter installed on brackets connected to girder ends at continuity diaphragm.	95
Figure A-7 Protection of wiring for embedded sensors prior to concrete casting.	96
Figure A-8 Surge protectors installed on one of every two embedded sensors at the same location.	96
Figure A-9 Solar panel powering the monitoring system.	97
Figure A-10 Campbell Scientific datalogger.	97
Figure A-11 Datalogger location while monitoring of curing girders in casting yard.	98
Figure A-12 Datalogger location in the complete system at bridge site. (Bent 24).	98
Figure A-13 Curing of bridge deck.	99
Figure A-14 Distribution of sensors on system multiplexers.	102
Figure A-15 Distribution of sensors on system multiplexers.	103
Figure A-16 Distribution of sensors on system multiplexers.	104
Figure A-17 Distribution of sensors on system multiplexers.	105
Figure A-18 Distribution of sensors on system multiplexers (MUX1 through MUX6).	106
Figure B-1 Introducing custom cross-sectional dimensions of I-girders.	107
Figure B-2 Allowing unsymmetric span lengths for bridges with more than two spans.	108
Figure B-3 Introducing different strand configurations for each span length.	109
Figure B-4 Resulting output for a five span bridge which also shows the age extension to 20000 days.	110
Figure D-1 Portable scales used in weighing individual truck axles.	133

Figure D-2 Dimensions and weights of trucks used in live load tests. 134
Figure E-1 Geometry, node and co-ordinate for SOLID5 element. 156
Figure E-2 Geometry, node location and co-ordinate system for LINK68. 157
Figure E-3 Geometry, node location and co-ordinate system for SOLID65. 158
Figure E-4 Geometry, node location and co-ordinate system for LINK8. 158
Figure E-5 Geometry, node location and co-ordinate system for SOLID45. 159
Figure E-6 Geometry, node location and co-ordinate system for CONTA178. 160

DRAFT

INTRODUCTION

Continuity in Precast Prestressed Girder Bridges

The construction of highway bridges using precast prestressed concrete (PSC) girders is considered one of the most economical construction alternatives. Not only does it eliminate the need for cumbersome formwork that is costly and may negatively impact daily activities around the construction site, but also speeds up the construction time since the precast PSC girders are only erected after being cured in the casting yard. One of the challenges for precast construction has always been the development of connection details that achieve the design goals without affecting the ease of construction. By default, precast elements are not connected monolithically. Therefore, many of the existing precast PSC girder bridges are constructed as simply supported spans as can be seen in Figure 1-a. The existence of expansion joints between spans is known to cause serious maintenance problems due to the accumulation of debris in the joints and the deterioration of elements in their vicinity (e.g. girder ends) due to drainage water leaks. Several continuity details have been used over the years in the bridge industry for slab-on-girder bridges with the goal of avoiding the aforementioned maintenance issues and reaping the benefits of continuity without the drawbacks of introducing it in large structures such as bridges (e.g. thermal movements). The continuity details can be categorized into two types, namely *full integration* details and *partial integration* details. Full integration details (Figure 1-b) result in a fully continuous structure (both deck and girders) that can resist the bending moments that develop at the supports due to long term, thermal, and live load effects. In bridges with partial integration details (Figure 1-c), the expansion joints are eliminated by casting a continuous deck over the support, while allowing adjacent girders some movements with respect to each other, thus relieving some of the continuity effects.

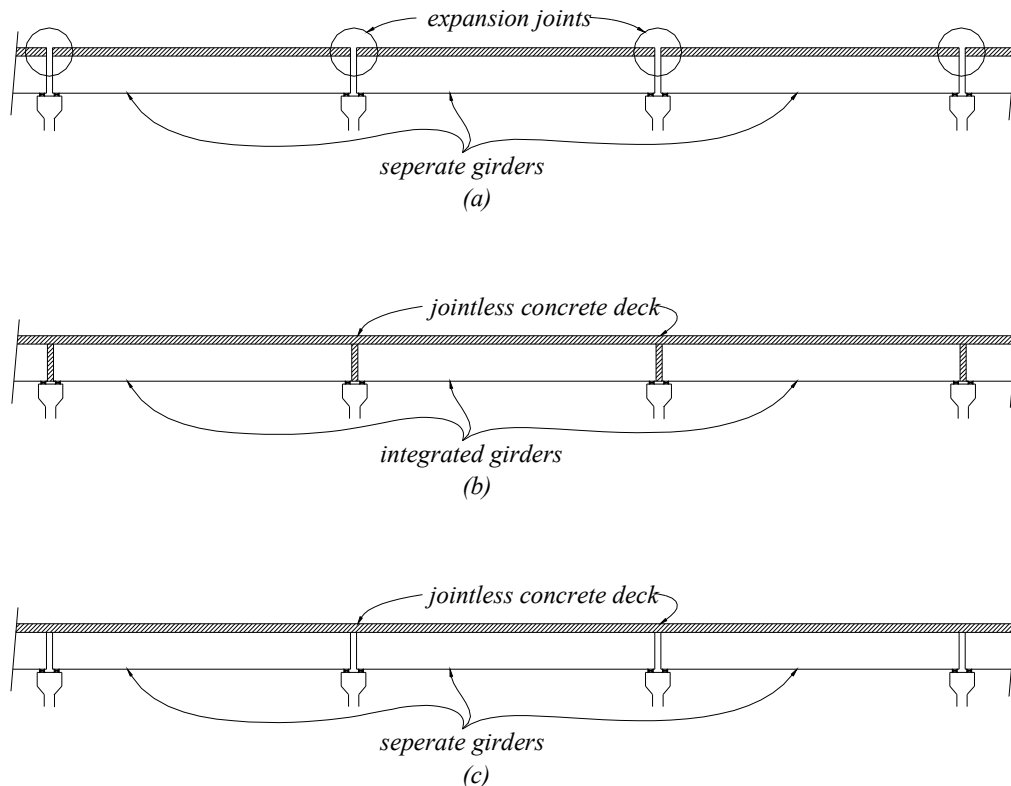


Figure 1
Typical continuity conditions in precast PSC girder bridges:
(a) simply-supported, (b) fully continuous, (c) partially continuous. (2)

Negative as well as positive moments develop over the continuous support once continuity is established in the system. Negative moments can be easily resisted by the abundance of tensile reinforcement in the deck and the ability of bottom flanges of precast PSC girders to transfer compression forces from one span to another through the diaphragm. The compression forces in the flanges of adjacent girders are transferred through the continuity diaphragm. Positive moments mainly develop in continuous bridge structures due to long term effects (e.g. creep) as can be seen in Figure 2. They cause compression in the deck over the support, which is not a problem because of the large deck area. However, the tensile forces developing in the girders' bottom flanges cannot be easily transferred from one span to the other. There are two solutions for the positive continuity moment problem. The first relies on providing additional bottom reinforcement at the girder ends that go through the continuity diaphragms to transfer the tensile forces between adjacent spans. This approach leads to *full integration* of the structure. Conversely, the designer may opt to relieve the

tensile force by separating girder ends and allowing some movement between the girder bottoms while maintaining the deck continuity. This option leads to a *partially continuous* structure.

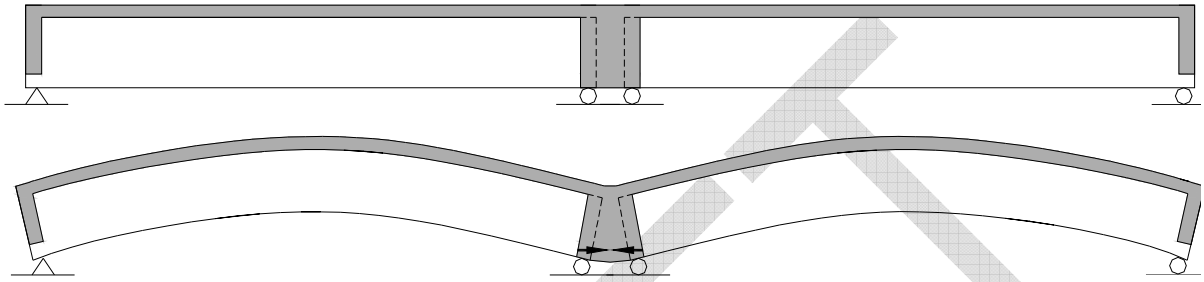


Figure 2
Development of positive moment in bridge connections with continuity diaphragm.

The Louisiana Department of Transportation and Development (LA-DOTD) adopts a detail that can be categorized under *partial integration*. In the current detail, girder ends are debonded from the continuity diaphragm by providing an asphaltic material layer as can be seen in Figure 3. A continuous deck is cast over the support. The debonding allows some movement of the girder ends from adjacent spans with respect to each other. Because of the existence of the diaphragm and continuous deck, the relative movement becomes more restrained at the top of the girder in comparison with the bottom. Despite the ability of this detail to resist negative moments, spans are conservatively designed as simply supported spans without taking advantage of the continuity. This approach may be justified based on the fact that if both girders are cambered up due to creep or thermal gradients, a gap may develop between girder ends from adjacent spans and the diaphragm. A negative moment effect will first have to close this gap before a compression force can be transferred; i.e. the negative moment, or part of it, will be redistributed.

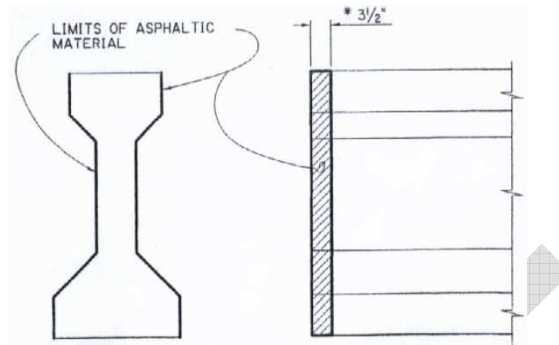


Figure 3
Bond breaker at girder ends

The new John James Audubon Bridge crossing the Mississippi River in Saint Francisville, LA, consists of eight bridges including the main cable-stayed span over the river. The designer of Bridge#2 adopted a detail that is different than the current continuity diaphragm standard used in Louisiana. It is based on the recommendations of the National Cooperative Highway Research Program (NCHRP) Project 12-53 (1). The adopted detail introduces positive reinforcement in the form of hairpin bars to the bottom at girder ends. The hairpin bars extend outside the girders and into the continuity diaphragm. LA-DOTD seized the unique opportunity by calling for an investigation into the performance of this new detail. The Louisiana Transportation Research Center (LTRC) is managing the project which is conducted by a research team from Louisiana State University. This report summarizes the efforts and findings from the research project. The evaluation of the performance of the continuity detail is based on structural health monitoring, and on analytical investigations that look into more details than what can be obtained from a single bridge.

Historic Background

The behavior of bridges continuity detail has been studied by several researchers. The majority of the work is related to the full integration technique. For example, Loveall (3) and Wasserman (4) reported their experience with jointless bridge decks over continuous girders. Russell and Gerken (5) wrote about the *Knowns and Unknowns* of jointless bridges. Burke, Jr. (6; 7) discussed the attributes and limitations of integral bridges. He also demonstrated some of the adverse effects of full bridge integration due to the buildup of stresses in concrete pavements (8). Alampalli and Yannotti (9) surveyed the integral and jointless-deck bridge inventory in the State of New York, US, indicating that their performance is as

designed. They recommended some new details for future projects to avoid some of the problems noted in the existing bridges. Thippeswamy et al. (10) also evaluated the performance of in-service jointless bridges.

Documentation of bridges that have been constructed or rehabilitated using one of the mentioned approaches can also be found in the literature. Demartini and Haywood (11) reported their work on the repair of the Story Bridge in Australia by eliminating contraction joints. A redecking case study where joints were eliminated was reported by Pierce (12). The construction of a demonstration bridge with jointless decks in North Carolina, US, was reported by Caner and Zia (13). The positive performance of bridges with jointless decks in seismic zones is demonstrated by Caner et al. (14) using existing bridges in Turkey. More recently, Wing and Kowalsky (15) reported the results obtained from monitoring an instrumented jointless bridge with debonded link slabs that was constructed as a pilot bridge in North Carolina. Long-term effects were also investigated by several researchers (7; 16). The results from these studies indicate that within certain limits, long-term effects may be ignored. This finding simplifies the analysis considerably. Several methods for the analysis of jointless deck systems were proposed (13; 17-20). Most of these methods are based on the finite element method, where researchers developed special computer code to incorporate the specifics of the jointless deck problem in the analysis. In a recent study by Okeil and El-Safty (2), a simplified analysis method was developed for jointless bridges. In this study, two support configurations, an upper and a lower bound, are considered. Closed-form expressions were derived and used to develop design tables that eliminate the need for computationally intensive finite element analyses.

NCHRP Projects 12-29, 12-53 and Related Research

In 1989, the National Cooperative Highway Research Program (NCHRP) published the findings from Project 12-29 in Report 322 titled *“Design of Precast Prestressed Bridge Girders Made Continuous”* (21), which is a comprehensive study on converting precast prestressed concrete girders into a continuous system. The authors of the report presented analytical methods for estimating the moments introduced by positive moment continuity details due to long-term as well as live load effects. It was concluded in the report that the construction of positive moment continuity details is *“difficult, time consuming, and costly.”* The authors also concluded that *“there is no structural advantage for providing positive moment reinforcement at the supports.”* It should be noted that thermal effects were not within the scope of the study.

Recently, NCHRP sponsored Project 12-53 (I) to survey current practices by different DOTs and to experimentally investigate the performance of positive moment continuity details. Design methods and tools were also developed for the design of live loads on bridges with the recommended continuity detail. Six specimens were fabricated and tested under cyclic loads until failure. Continuity details where positive moment reinforcement extends from the bottom flange at girder ends were investigated. Additional hairpin/hooked bars or prestressing strands can be utilized as can be seen in Figure 4. The conclusion from the study is that positive moment continuity details are not costly (\$200 per girder). It was recommended that positive moment connections should be designed for a capacity less than $1.2 M_{cr}$, since connections with higher capacities are not efficient. To reduce the applied moments, and therefore reduce the possibility of diaphragm cracking because of the concern that diaphragm cracking can lead to loss of continuity, the report recommends that the continuity be introduced after the 90 days or more after casting the PSC girders. The 90-day girder age limit was based on the response to the survey and from analytical results to. Experimental results showed that the loss of continuity was not seen until the connection was close to failure, and even then, the loss was about 30%. Furthermore, the authors of the report stated that positive moment continuity details also enhance the structural integrity of the bridge even if they do not reduce the total design moment. The authors of NCHRP Report 519 recommended further research to study the performance of the recommended positive moment continuity details in full-size specimens since the tested specimens were single line AASHTO Type II girders. The effects of bridge skew and thermal changes were not investigated.

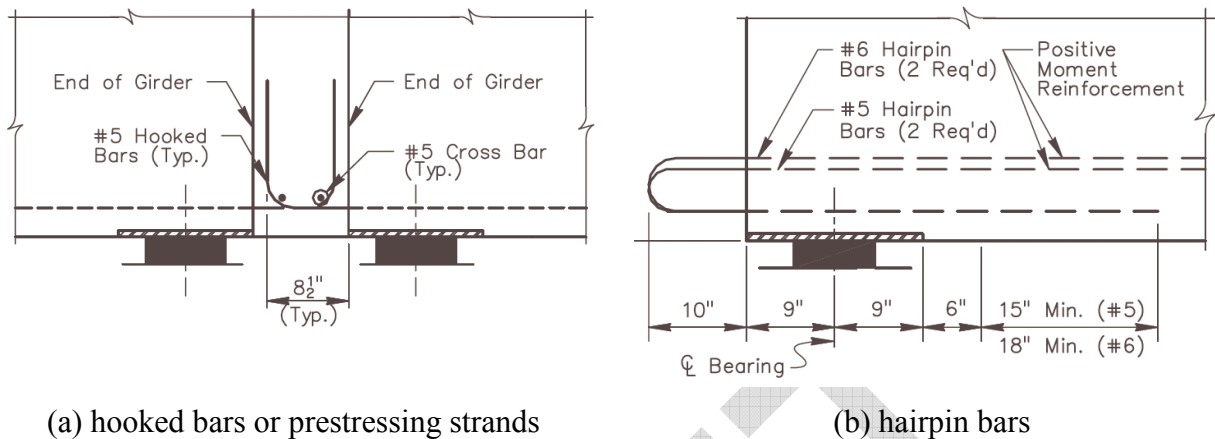


Figure 4
Alternatives for positive moment reinforcement (I)

A thorough investigation of prestressed concrete Bulb-T (PCBT) girder bridges with positive moment continuity details as those recommended in NCHRP Report 519 was the subject of a Ph.D. dissertation in Virginia Polytechnic Institute and State University (22). Experimental and analytical investigations were carried out on a 45-inch PCBT. It was concluded by the author that the restraint moments due to thermal influences measured during the study appear equally significant, or even more significant, than the restraint moments due to creep and shrinkage. Therefore, it was recommended that thermal restraint moments should be considered in the design. One specimen had the prestressing strands extend into the diaphragm to provide the positive moment reinforcement, while the other relied on 180° bent (hairpin) bars. A third specimen was also tested where no continuity diaphragm was provided, however, the deck was cast continuous over the support. It was concluded that the hairpin detail results in a stiffer connection than the bent-up prestressing strand detail, and therefore, it was recommended that the hairpin detail be used if a continuous deck is to be cast over the support. The conducted research only looked at single-line specimens and therefore did not study the effect of bridge skew. Furthermore, the size of the specific PCBT girders used in manufacturing the specimens is almost equal to an AASHTO Type IV. In other words, large Bulb-T sections (e.g. BT-72) have not been investigated.

Louisiana Research on Bridge Diaphragms

In Louisiana, several research projects that address bridge diaphragms were conducted through LTRC. The effectiveness of continuity diaphragms in skewed PSC girder bridges was investigated in Project 01-1ST (23). The necessity of providing continuity diaphragm over the skew bent and its effects on the distribution of stress and deflections were investigated using an elastic finite element model. The parameters considered in the analysis were the skew angle of the bent, span length, girder spacing, girder types and diaphragm condition. The analytical results showed that the effect of continuity diaphragm on the stress and deflection is limited, and can be omitted. The authors finally concluded that the continuity diaphragms may improve the load distribution characteristics, but their effectiveness for skewed continuous bridges is limited. Since this effort was based on analytical results, the authors recommended that laboratory tests and field measurements be considered to verify the theoretical results. The field investigation was the focus of the second study on the performance of continuity diaphragms in skewed PSC girder bridges (*Project 06-3ST - 24*). In this project, the Burlington Northern Santa Fe (BNSF) overpass was load tested using one truck with a gross vehicle weight (GVW) equal to 48.66-kip. The span length for the tested overpass was 79 feet with a skew angle (defined as the angle between the centerline of a support and a line normal to the roadway centerline) was 48°. AASHTO Type III girders spaced at 8 feet carried an 8 inch reinforced concrete deck. Strains and deflections were compared with those determined through theoretical analyses. The authors concluded that continuity diaphragms used in PSC girder bridges on skewed bents provided additional redundancy in the bridge, but their effects are negligible and caused difficulties in detailing and construction, especially for bridges with high skew angles and/or narrow girder spacing.

Intermediate diaphragms (ID) in PSC girder bridges were investigated by another LTRC project (*Project 03-3ST - 25*). Analytical investigations were conducted to assess the need for IDs in precast PSC girder bridges. The results showed that several parameters such as skew, span length, spacing, stiffness of diaphragm and girder influence the effectiveness of diaphragms in live load distribution for bridges. The research team also tested a bridge over Cypress Bayou on LA 408 East. The authors concluded that reinforced concrete IDs are beneficial in distributing lateral impact forces from over height trucks. Gravity live load distribution is also influenced by IDs, which can be addressed by modification factors to current AASHTO formulas. Stability of precast PSC girders during construction is an issue

that can be addressed by steel intermediate diaphragms rather than the reinforced concrete diaphragms, which increase the cost and time of construction.

Calculation of Restraint Moment

Study on precast/prestressed concrete bridges made continuous is started in early 1960s. Mattock (26) in his fifth study reported an experimental and analytical investigation of the influence of creep of precast girders and of differential shrinkage between precast girders and cast-in-situ deck slab on continuity behavior. In this early study, it was concluded that positive restraint moments may develop at the interior support sections of the continuous girders, which may result in cracking at the bottom of the diaphragm at these sections. The developed restraint moments, and the resulting cracking if any, will affect the behavior of the girders at the service load level. Design recommendations are suggested for the critical girder sections, considering restraint moments due to long-term deformations.

Freyermuth (27) used the results from Mattock's studies and presented a complete design procedure, popularly known as Portland Cement Association (PCA) method for calculating restraint moments. In NCHRP Project 12-29, Oesterle et al. (21) developed a computer program BRIDGERM to calculate time dependent restraint moments based on the PCA method, with several improvements including time-step analysis proposed by Construction Technology Laboratories (CTL) and is called as CTL method.

Peterman and Ramirez (28) proposed a modification to the restraint moment calculations by PCA and CTL methods and named it as *P*-method, intended for bridges with precast/prestressed concrete form panels. McDonagh and Hinkley (29) proposed a new computer program RMCALC, to compute restraint moments using Microsoft Windows Platform. RMCALC is essentially a repackaging of BRIDGERM where a graphical user interface is added to convert it into a more user-friendly design tool.

The most recent analysis tool was developed as part of Project 12-53 (1). The spreadsheet tool is a program called RESTRAINT that calculates restraint moments in continuous PSC bridges. RESTRAINT uses both PCA and CTL methods with some modifications. This method is described in detail in the METHODOLOGY/Analytical Model section.

Research Needs

As can be seen from the review of previous work, it is inconclusive whether the benefits of introducing continuity diaphragms justify the additional cost and time required for their construction or not. The performance of continuity diaphragms has also been the subject for debate. Some researchers concluded (21; 23; 24) that the effect of continuity diaphragms on bridge design is of negligible or no structural benefit. Other researchers concluded that they perform well if properly designed to avoid loss of continuity (1; 22). Furthermore, the performance of positive moment continuity details in full size bridges rather than single line laboratory specimens was not investigated to the best of the research team's knowledge, especially for skewed spans.

The Louisiana Department of Transportation and Development (LA-DOTD) seized an opportunity from the construction of a design-build project in Louisiana where the designer adopted the NCHRP 519 positive moment continuity detail. A research project through LTRC (08-1ST) was initiated to assess the performance of the detail in a full-size bridge. A structural health monitoring (SHM) approach was adopted for the task. A SHM system was installed and has been monitored for almost 24 months since the completion of the bridge in November 2010. A live load test was also conducted in August 2010. This report summarizes the data from the SHM results and additional analytical results.

DRAFT

OBJECTIVE

The main objective of this project is to install a monitoring system for the purpose of investigating the performance of a continuity diaphragm detail that is newly introduced in Louisiana and is employed in Bridge #2 of the James Audubon bridge project. The investigation of the detail's performance under long-term (creep, shrinkage, and thermal) and live load effects is conducted to validate the performance of the NCHRP 519 continuity detail for a skewed span with Bulb-T girders.

The goals of the project are to:

5. Collect, analyze, and interpret field monitoring data to understand the behavior of Bridge #2 under long-term and live load effects.
6. Develop a robust analysis tool that accounts for continuity diaphragm properties and is capable of analyzing general bridge configurations (e.g. unsymmetric span lengths).
7. Provide LA-DOTD with recommendations for the implementation of the NCHRP 519 continuity in future projects based on a full understanding of the behavior of the continuity diaphragm connection detail.

DRAFT

SCOPE

This study focuses on the performance of NCHRP 519 positive moment continuity detail in a skewed bridge segment that exists in Bridge #2 of the John James Audubon Project. Because of the nature of the adopted methodology; i.e. structural health monitoring (SHM), the project activities and findings are limited to the specifics of the monitored bridge (skewed segment with Bulb-T girders). The main focus of the project activities is to monitor long-term (creep, shrinkage, and thermal) effects on the continuity detail. The effects of live loads on the detail are also investigated.

Comparison between the performance of the monitored bridge segment and bridges with different continuity details was not possible because of the lack of monitoring data from similar bridges with different continuity details. Analytical investigations are therefore utilized to provide comparative information.

The results from this investigation are thoroughly documented to serve as a reference point for future projects that monitor similar, and other, continuity details.

DRAFT

METHODOLOGY

The assessment of the performance of positive moment continuity details was assessed using three different approaches. They are:

- Structural health monitoring (SHM) of a bridge in service that employs the detail from the beginning of construction.
- Assessment of the restraint moments that develop in continuous structures over a wide range of parameters using the computer program RESTRAINT after expanding its capabilities to include conditions specific to the bridge used in this study.
- Finite element (FE) analyses of global as well as local behavior of the monitored bridges.

The performance of the positive moment continuity detail was assessed for long-term and live load effects. The following sections describe the details of all three assessment methods and the live load test.

Structural Health Monitoring

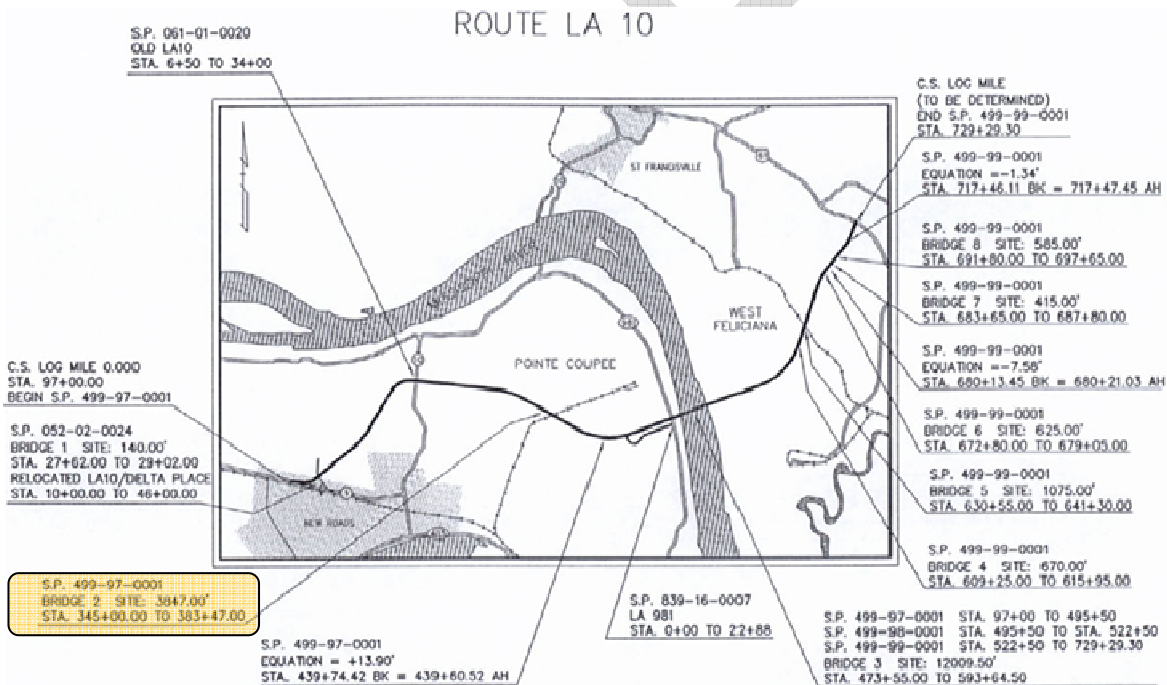
A structural health monitoring plan was devised for the bridge chosen by LA-DOTD to conduct the assessment study. This section describes the details of the monitored bridge, instrumentation plan, data processing and interpretation.

Description of Monitored Bridge

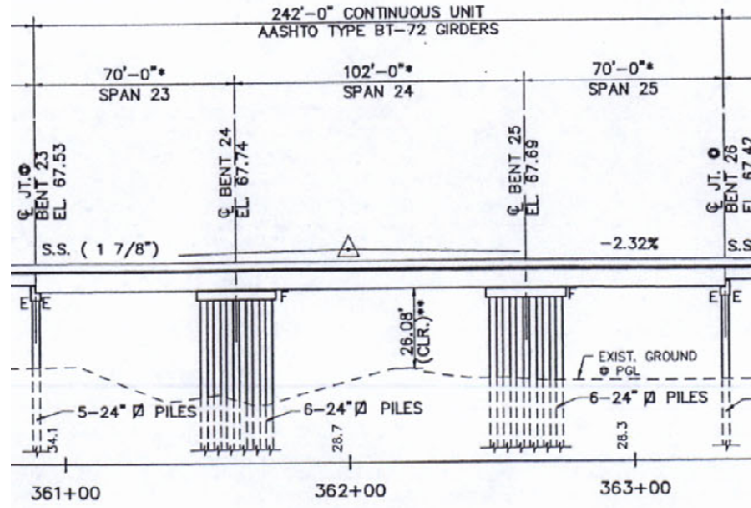
Bridge #2 is one of 8 bridges in the John James Audubon Project that will add a new transportation artery across the Mississippi River between the cities of New Roads and Saint Francisville (see Figure 5-a). The purpose of Bridge #2 is to cross an existing railway track. The 52-span bridge has a total length of about 4000 ft which is divided into 14 continuous segments. The LA-DOTD chose a 242-foot segment for monitoring the performance of the adopted continuity detail. The segment is a three span continuous superstructure with a skewed layout for its middle and longest span (102 feet). The exterior spans were 70 feet long and can be seen in Figure 5-b. Because of the 45°-skew of the middle span, the girders supporting the exterior spans ranged in length from 51 feet to 89 feet as can be seen in Figure

6-a. The chosen segment is constructed using AASHTO Bulb-T girders (BT-72). Because of the antisymmetry of the bridge, only one of the identical intermediate bents (Bent 24 and Bent 25) was chosen for the investigation. This segment was chosen because of its configuration, which has not been covered by the tests conducted in NCHRP Project 12-53; namely skewed configuration and Bulb-T girders.

Figure 6-b shows a cross section of the monitored bridge segment, which supports a clear roadway width of 38 feet on five prestressed BT-72 girders spaced at 8.25 feet. The 7.5-inch reinforced concrete deck is monolithically cast with the continuity diaphragm joining adjacent girders over intermediate bents. Hairpin bars were embedded in the girders and extended 8 inches outside the girder ends to provide positive reinforcement. It should be noted that the girders are supported by rubber bearing pads over typical pile bents.



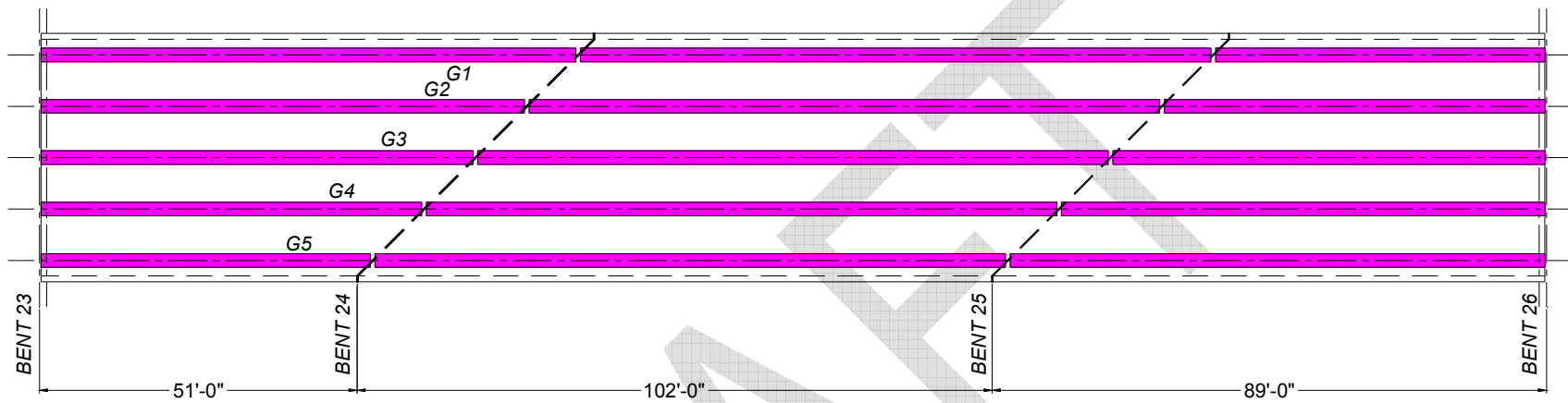
Map of bridge site location



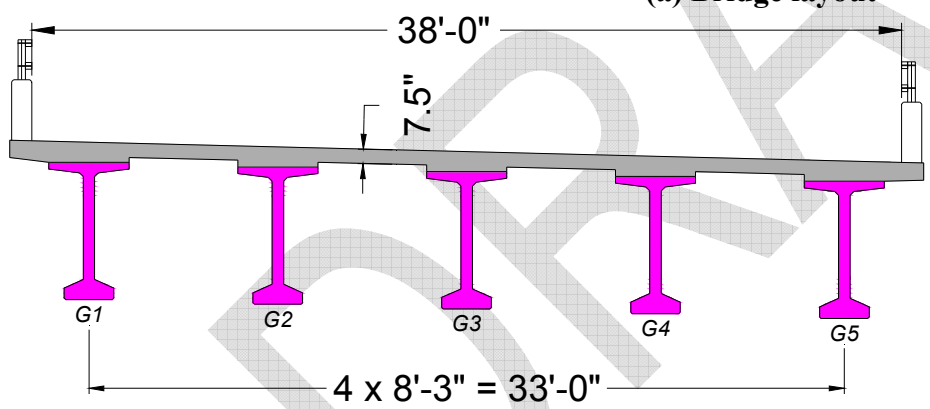
Elevation of chosen segment
 Figure 5

Bridge #2 chosen by LA-DOTD for monitoring the continuity detail.

DRAFT



(a) Bridge layout



(b) Cross section and continuity detail (5#5 hairpin bars)

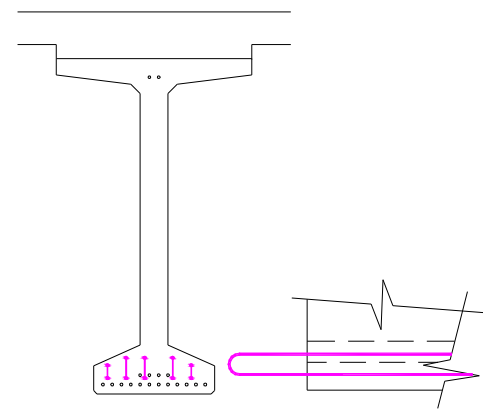


Figure 6

Main dimensions of monitored Bridge #2

Material Properties and Fabrication Details

The PSC girders were cast in June 2008. Three standard concrete cylinders and one prism were taken from the monitored beams and were tested in the Concrete Research Laboratory at LTRC. Two of the cylinders were tested to determine the compressive strength after 28 days according to ASTM C 39 (30) and the third cylinder was used to determine the concrete's modulus of elasticity, E_c , according to ASTM C 469 (31). The modulus of rupture was determined using the 6in x 6in x 20in in three point bending according to ASTM C 78 (32). The deck specimens from the deck pour were also collected and tested. Three cylinders were tested in compressive strength, one cylinder was tested for the modulus of elasticity, and a splitting tensile strength test (ASTM C496 - 33) was conducted instead of the modulus of rupture test.

Table 1
Mechanical properties for concrete

Test	Girder / Span							Deck
	G1 S23	G3 S23	G1 S24	G3 S24	G4 S24	G5* S24	G5** S24	
Date of Pour	6/13	6/13	6/18	6/18	6/18	6/18	8/9	11/18
Date of Test	7/11	7/11	7/16	7/16	7/16	7/16	9/9	12/16
Age (days)	28	28	28	28	28	28	31	28
ASTM C 39 (psi) (f'_c - Cylinder #1)	8864	9711	9420	10079	10555	10579	1076 6	--
ASTM C 39 (psi) (f'_c - Cylinder #2)	9101	9480	9266	9860	10429	10322	1091 2	--
Average (psi)	8983	9596	9343	9970	10492	10451	1083 9	6591
ASTM C 469 (ksi) (E_c - Cylinder #3)	6450	6600	6100	6450	5850	6450	5850	6175
ASTM C 78 (psi) (f_r - Prism)	948	1082	1165	1150	1074	1171	1203	--
ASTM C 496 (psi) (f_{sp} - Prism)	--	--	--	--	--	--	--	372

* Rejected girder

** Replacement girder

The stress strain relationship for the prestressing strands was obtained from the project's records and can be seen in Figure 7. The points that can be seen on the smooth relationship

are digitized points on the plot to help in establishing a theoretical stress-strain relationship for future analyses.

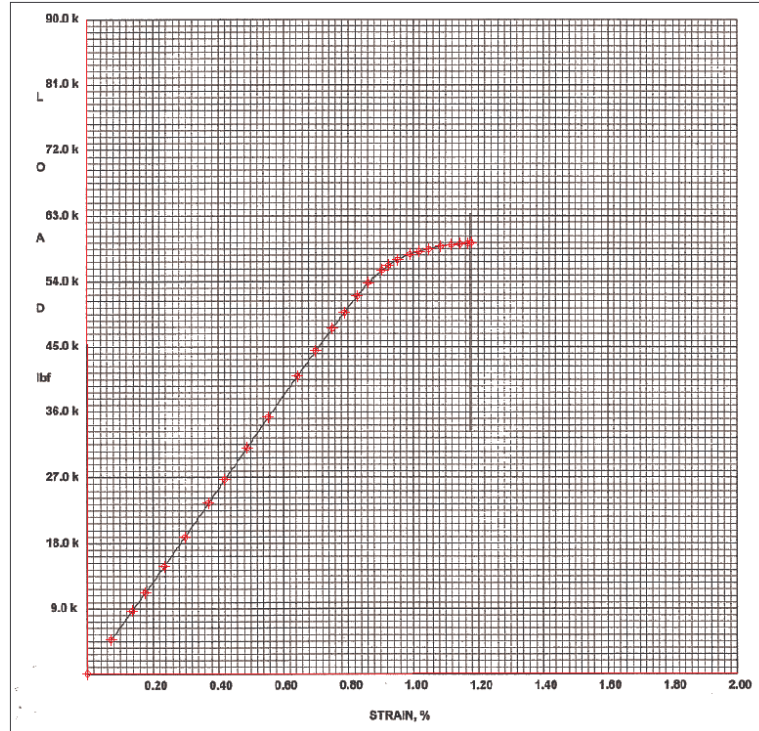


Figure 7
Stress-strain relationship for prestressing strands

Instrumentation Plan

The monitoring system was designed to capture: (1) the tensile force in the positive moment reinforcement, (2) the strain distribution at key locations (intermediate bent and midspan), (3) differential shrinkage between cast-in-place (CIP) deck and precast girders, (4) degree of continuity between adjacent girders, (5) the development of cracks or gaps at the continuity diaphragm, and finally (6) the corresponding temperature for each of the recorded readings. In selecting the sensor locations, the research team identified the most critical locations that deliver the information required to assess the performance of the continuity detail. In most locations where embedded sensors were employed, two sensors were used to reduce the risk of losing sensors during the casting of girders. Furthermore, surge protection was provided to

one of each two sensors at the same location in case of the bridge being hit by lightning since replacing embedded sensors is not possible.

One of the major causes of the development of positive moment in continuous structures is long-term effects; namely, creep and thermal deformations. Therefore, all the selected gages employed vibrating wire technology. Vibrating wire gages convert the change in resonant frequencies in an internal wire into an output reading that represents the relative movement between the wire ends. Gages that can measure strain, displacement, slope are available and were employed in the system. Table 3 lists the type and number of each of the employed sensors. Both embedded and external (surface mounted) sensors were used. The technical specifications for the sensors used in this study are summarized in Table 2. The total number of sensors installed from each type is listed in Table 3. Reducing the number of sensors was possible by taking advantage of the bridge's antisymmetry shown in Figure 8 under symmetric loading conditions such as long-term effects, which is the focus of this study. Three positive moment connections were fully instrumented (connecting Girders G1, G3, and G5) at the support. Embedded sensors were installed in the deck over the support at remaining two girders. At midspan, three girders (Girders G3, G4, and G5) were fully instrumented. Along the midspan line, Girder G1 is identical to Girder G5 and Girder G2 is identical to Girder G4. Therefore, information across the the midspan section is attainable.

Figure 9 shows the final instrumentation plan where the monitored girders, sensor types, locations, and numbers can be seen. It should be noted that this plan is almost identical to the approved instrumentation plan except for few minor changes. For example, Girder G5 was not instrumented with embedded strandmeters because the research team was not informed by the precaster of its casting date. Another example is also related to Girder G5 in Span 24 where all sensors in the approved instrumentation plan were initially installed. However, due to circumstances beyond the research team's control, that girder was rejected by the contractor. As a result, the research team had to install new sensors in the replacement girder with less a 24 hour notice. It was only possible to install 4 of the 6 embedded sensors in the original plan; i.e. two strandmeters at midspan were not installed in the replacement girder. The decision to install the available strandmeters at the support was based on prioritizing that location as more important because of its vicinity to the continuity and because there were sisterbars at midspan that would still yield usefull information for that location.

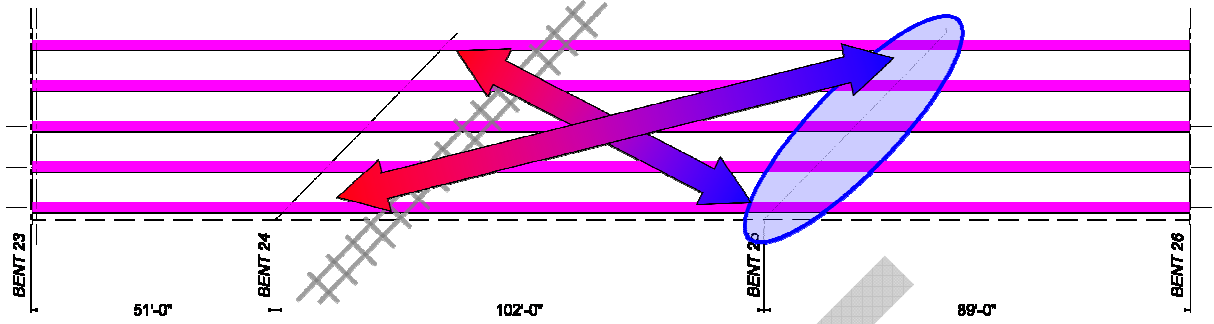
Table 2
Technical specifications of employed sensors

Type	Frequency Range (Hz)		Gage Length	Range
	Low	High	Inches	Inches
EC = Sisterbar	2600	3200	n/a	96
ES = Strandmeter	1500	2700	8.0	0.1181
TM = Tiltmeter	1700	3500	n/a	+/- 5 degrees
VW = VW Strain Gage	500	1100	5.875	3000 (microstrain)
DM1 = (25mm) Crackmeter	1400	3000	13.1	1.00
DM2 = (50mm) Gapmeter	1400	3000	14.9	2.00

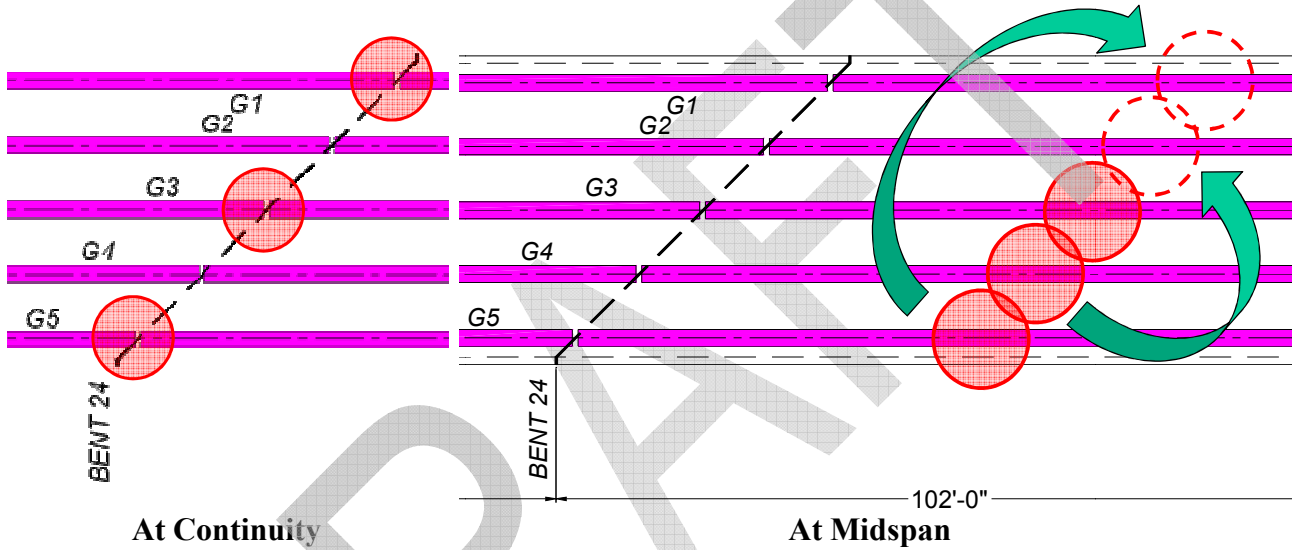
Table 3
Types and number of sensors employed in this study

Sensor Type	Measurement	Location	Number
Sisterbars (VW4911)	Strain in concrete	Embedded	12
Strandmeters (VW4410)	Strain in reinforcement		16
Strain gages (VW4000)	Surface strains	Surface Mounted	29
Gapmeters (VW4420)	Gap width		3
Tiltmeter (VW6350)	Slope		6
Crackmeter*	Crack width		10
Total:			66

*Crackmeters were not installed due to lack of significant cracking.



General Layout



At Continuity

At Midspan

Figure 8

Antisymmetry of Bridge #2 allowed monitoring only one of the continuity details

INSTRUMENTATION PLAN (ALL)

	Support Line #2	Joint #3	Mid-span	
Embedded Strain gauge (sisterbars)	EC = 0	+ 3	+ 0	+ 9 = 12
Embedded Strain gauge (strandmeter)	ES = 4	+ 2	+ 6	+ 4 = 16
Vibrating Wire Strain gauge	VW = 9	+ 0	+ 9	+ 11 = 29
Vibrating Wire Tiltmeter	TM = 3	+ 0	+ 3	+ 0 = 6
Displacement Meters	DM = 0	+ 3	+ 0	+ 0 = 3
Total	=16	+ 8	+18	+ 24 = 66 (actual number of installed sensors)

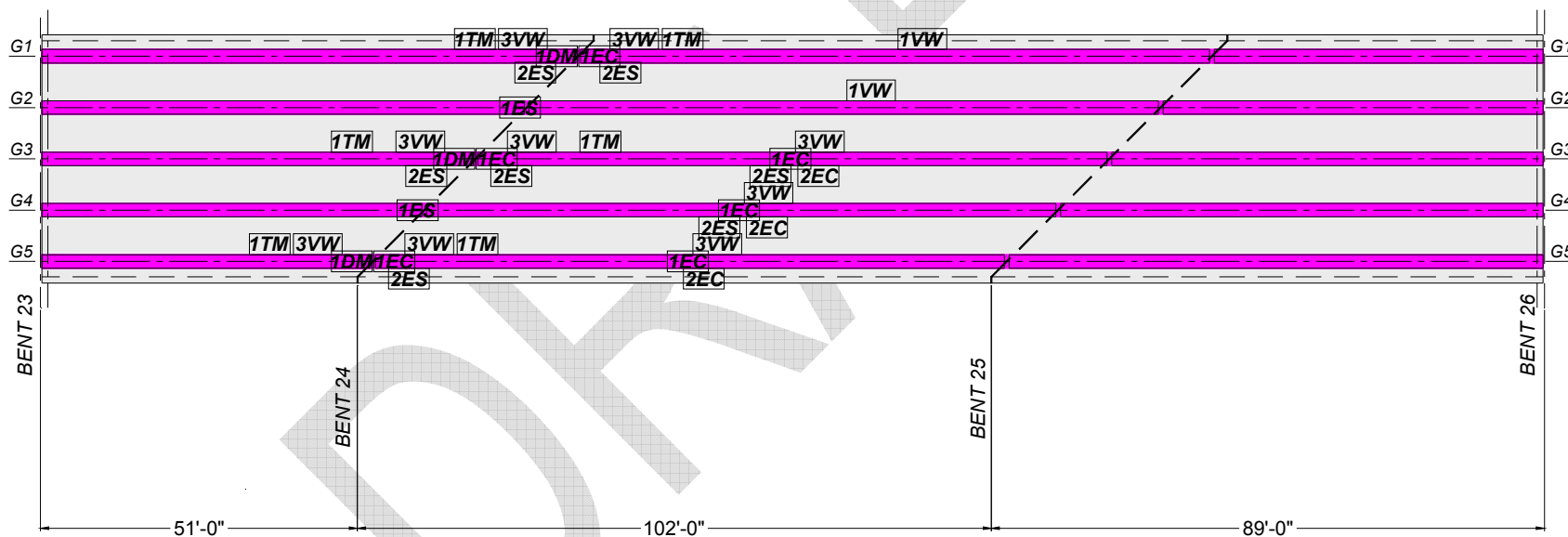


Figure 9
Instrumentation Plan for structural health monitoring of positive moment continuity detail in Bridge #2

Figure 10 shows the schematics of the sensor locations at monitored sections. The embedded strandmeters (ES) were installed on the hairpin bars or deck reinforcement at girder ends and on prestressing strands at midspan. Sisterbars (EC) were placed next to reinforcing bars in the deck or prestressing strands in the girders. Surface-mounted sensors were installed using mechanical anchors to the girder's surface. Three vibrating wire gages (VW) were installed at each monitored location. At the support, both sides of the continuity diaphragm were instrumented to study its ability to transfer forces from girders in one span to girders in the adjacent span. Tiltmeters (TM) were also installed at both sides of the continuity diaphragm to provide additional information about the level of continuity that the adopted detail is able to provide. Finally, a gap meter (DM) was installed to measure the relative movement between the bottom of girder ends. A pictorial documentation of the installed sensors and more details about them (serial numbers, MUX channel connectivity) can be found in APPENDIX A.

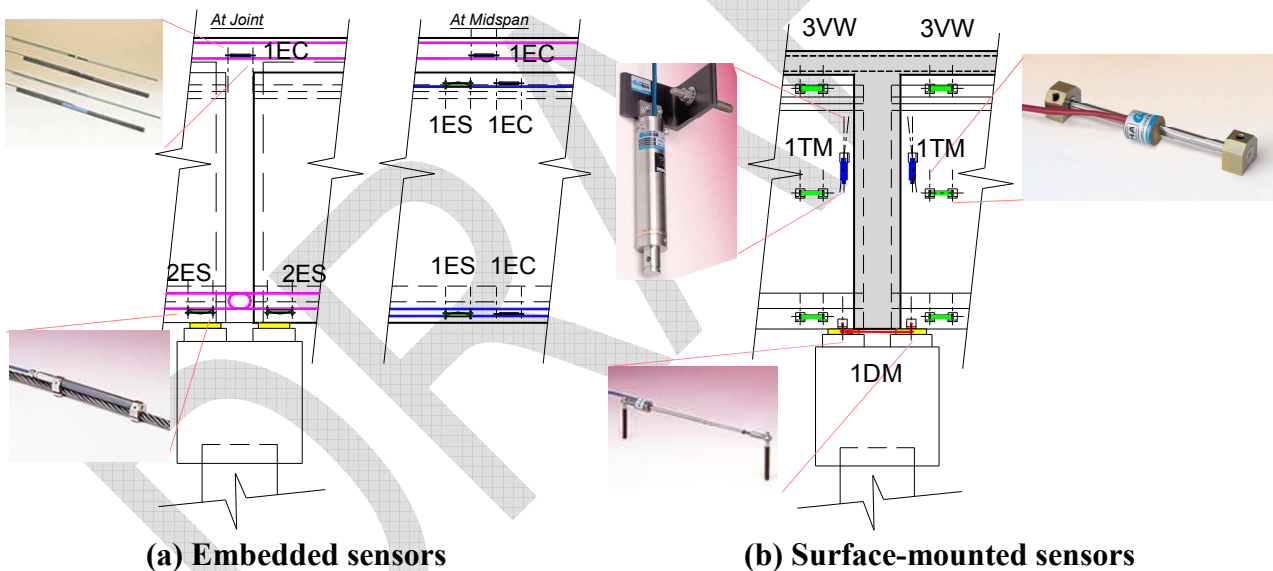


Figure 10
Sectional locations of embedded and surface-mounted sensors in Bridge #2

All the sensors are grouped into 6 multiplexers which are then connected to a Campbell Scientific datalogger. The datalogger is powered by one DC batteries which is recharged by a solar panel. The datalogger is equipped with a cellular modem that allows remote access to the data through an internet (IP – Internet Protocol) connection as can be seen in Figure 11. Two monitoring setups were used for the project. The first temporary setup covered the

period while the girders were curing in the casting yard. Out of the 24 installed embedded sensors, only 18 were connected to the monitoring system because some of the girders were stored far away from the datalogger. The setup lasted for 32 days until the girders had to be transported to the bridge site. The second monitoring setup is the permanent one. It came into service on January 9, 2009.



Figure 11
Communication between the datalogger (station) and the server.

Data Processing

Raw data obtained directly from the logger had to be first processed before it could be interpreted. The processing includes cleaning the record from any outliers, joining or disjoining records in case data channel was changed during the monitoring period, and temperature correction as specified by the sensor manufacturer. The following few sections briefly describe all three steps of data processing.

Removal of Outliers. As stated earlier, average hourly readings are recorded during the normal operation of the datalogger. If for any reason one of the 24 readings averaged within an hour is bad (e.g. due to a lightning hit or low voltage input), the recorded hourly average is affected and become undesirable datapoint. The large size of data (69 sensors over

24 months) makes the task of removing outliers manually a daunting task. Several data cleaning scripts were tested before the research team developed its own data cleaning routine that performs the task on a global scale first before scrutinizing a smaller user-specified window for any datapoints that fall out of a user-specified range of acceptable tolerance. Figure 12 shows plots of the raw and cleaned data records for sensor #22. It should be noted that the erratic readings during the period between 11/2008 and 03/2009 were due to inadequate power supply from the solar panel, which affected three sensors and was remedied in March 2009. In all cases, outlier datapoints were replaced with an Not-A-Number (NaN) record.

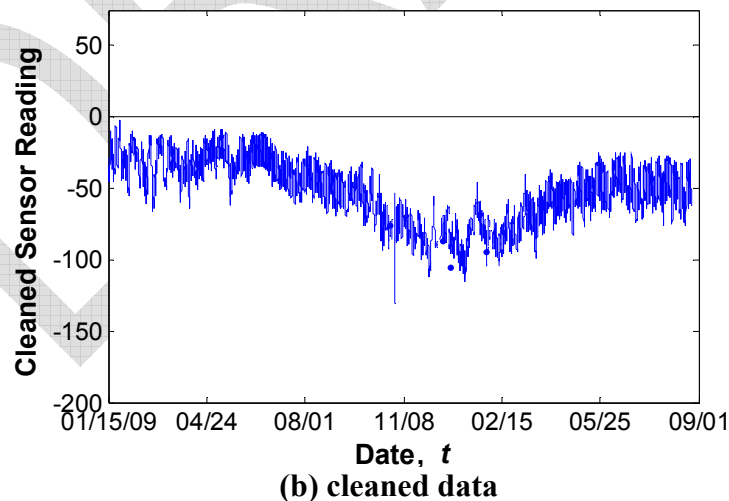
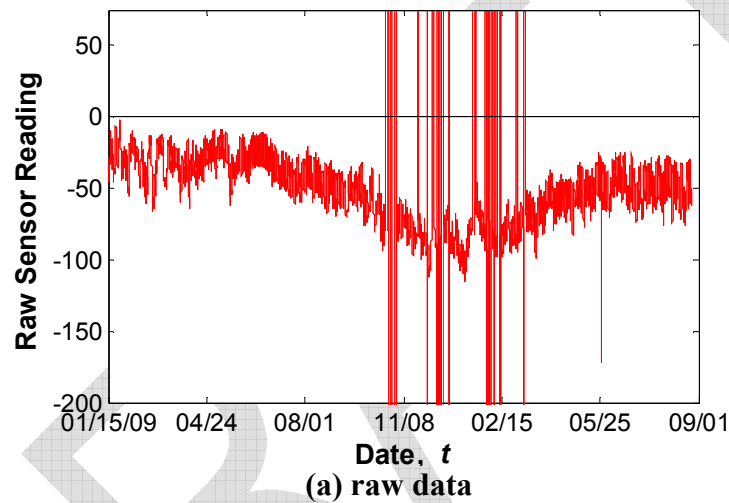
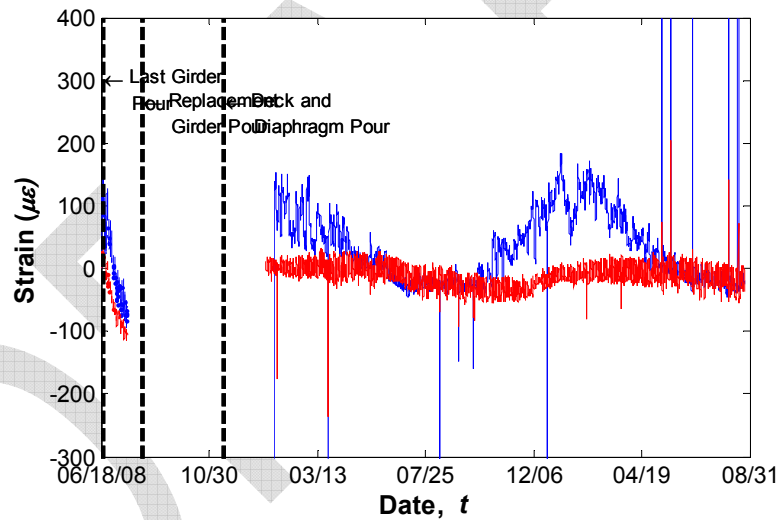


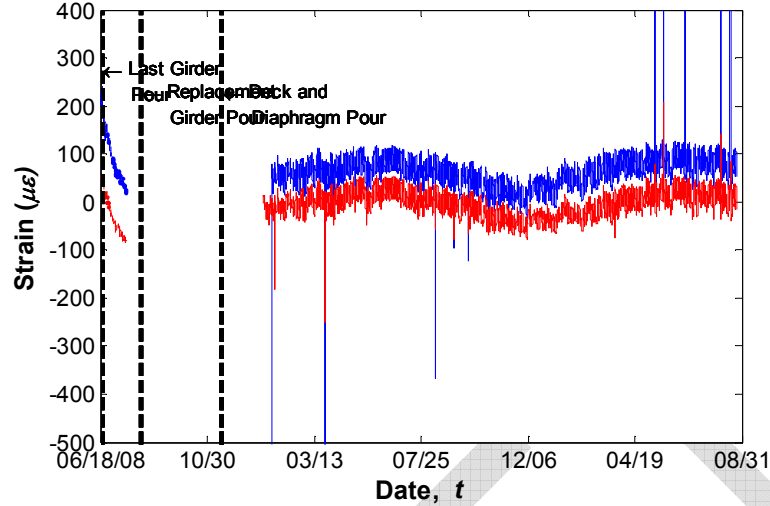
Figure 12

Removal of outliers from raw data (sensor #22 – VW on G1 (bottom) at Bent 24 in Span 23).

Temperature Correction. The manufacturer of the vibrating wire gages used in this study recommends correcting the recorded raw data to account for temperature variations that affect the length of the vibrating wire inside the gages, and hence, affecting its readings. Temperature corrections were applied to all sensors used in this study except for tiltmeters, for which temperature correction is not highly recommended. Figure 13 shows a plot of raw and temperature corrected data for a sisterbar and a strandmeter at the same location (bottom of Girder 3 in the middle of Span 24). It can be seen in Figure 13-a that the recorded raw data are quite different. This is mainly due to the different characteristics of both sensors such as different gage lengths. Figure 13-b shows that once the temperature correction is applied, the trend and range of variations from both sensors match very well. The shift between the reading may be due to the condition at the initial stages when the girder concrete was poured. If another datum is chosen, the shift between the relative strain recorded by both sensor types would drop substantially.



(a) raw data



(b) temperature corrected data

Figure 13

Temperature correction of sensors #88(ES) and #92(EC) in G3 (bottom) at Midspan 24).

Joining Data Records. During the fine tuning process of the system, two of the sensors were found to be malfunctioning. Both sensors were tiltmeters. In the trouble shooting phase, the malfunctioning tiltmeters were moved to different logger channels before ultimately replacing them. The records from different sensors at the same location had to be joined from different channels in the system after adjusting the relative readings at the beginning of each phase to the relative reading at the end of each phase. Figure 7 shows readings from tiltmeters on Girder G1 at both ends of the continuity diaphragm. It can be seen that one of the records reflects expected due to seasonal temperature variations while the other one (on Span 24) was almost constant until it was replaced with a malfunctioning tiltmeter (period between June 2009 and October 2009). Finally, when the sensor was replaced on October 7, 2009, a similar trend can be seen on both sides of the continuity diaphragm.

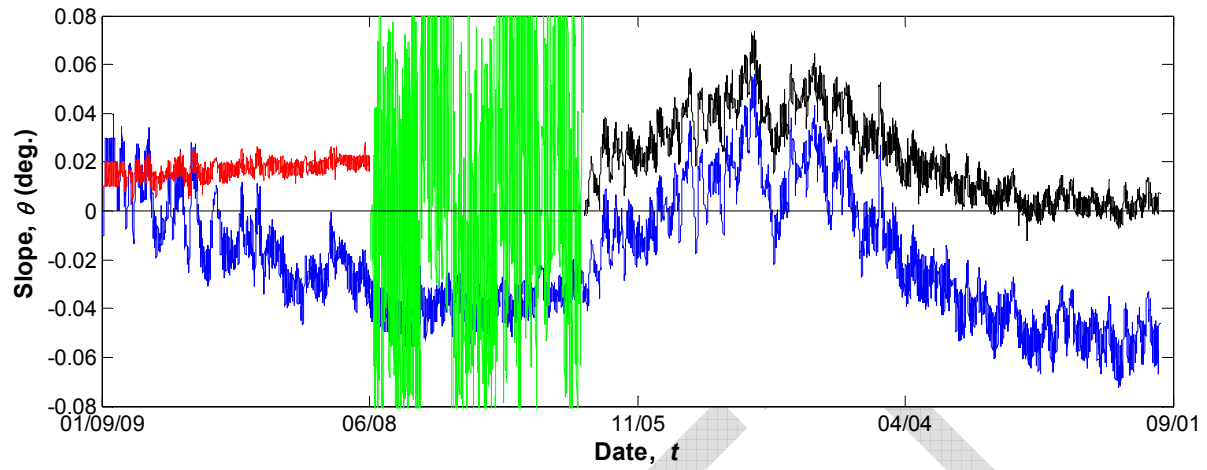


Figure 14
Joined data record for tiltmeter (TM) at G1 in Spans 23 and 24.

Continuity Assessment

*** Under Development ***

Analytical Model

In this section, the analysis model used in conducting the parametric study is described. It is based on the RESTRAINT program that was developed as part of NCHRP Project 12-53 (1). Because of the limitations that this program has, the research team modified it to expand its capabilities such that it could analyze a bridge with the configuration of Bridge #2. Furthermore, RESTRAINT was used to conduct parametric studies from which recommendations for the age of continuity were established.

RESTRAINT Program (NCHRP Project 12-53)

As mentioned earlier in the INTRODUCTION section, Miller et al. (1) developed an analytical model for the calculation of the restraining moment, M_r . This spreadsheet analytical model was later used to conduct parametric studies on continuous system with different moment connections. The model is based on BRIDGERM, which was developed as part of NCHRP Project 12-29 (21) and was named RESTRAINT. The program was initially developed to model a two-span continuous structure where the analysis is conducted on lines of girder and not the entire bridge. The model assumes that girders are supported at both ends. RESTRAINT uses a flexibility-based analysis (34) where the structure is discretized into several elements to predict the time-dependent response of precast/prestressed concrete girders made continuous. RESTRAINT accounts for the creep and shrinkage effects, prestress losses, age at loading, and construction sequence. Creep due to prestressing forces cause positive restraint moments in continuous bridges as a result of the upward camber movement. Conversely, Creep due to superimposed dead loads (after the introduction of continuity) cause negative restraint moments. Shrinkage of the concrete deck due to loss of moisture also causes a downward deflection, and therefore, causes negative restraint moments. The program uses creep and shrinkage strains based on the relationships given in ACI-209 report. The program also accounts for loss of prestressing force using the method given in the PCI handbook. Within each span, shrinkage of the deck and girder is assumed to be uniform, while creep caused by dead load plus prestressing force is assumed to be parabolic. The program allows different casting dates for the diaphragm; i.e. introduction of continuity, and the deck to be different. The diaphragm there is no prestressing, so the creep is 0. Since the slab and diaphragm are usually cast together, the differential shrinkage between them is assumed to be 0.

Limitations of RESTRAINT

RESTRAINT is capable of analyzing multispan bridges to estimate the restraint moment caused by the major factors that affect the behavior of continuous bridges, namely creep, shrinkage, age on continuity, prestress losses. However, the program has limitations to its range of applicability, which are summarized in the following:

- Span lengths have to be symmetric about the center of the bridge. In other words, if a three span bridge is to be analyzed, the first and third spans have to be equal. This limitation rendered the program unusable for the analysis of Bridge #2, except for Girder G3 line where the span lengths are symmetric. This limitation severely reduces the number of bridges within RESTRAINT's capabilities as many bridge span lengths are controlled by site conditions and cannot be freely configured to be symmetric.
- RESTRAINT does not provide option to enter specific properties for the continuity diaphragm, since it is assumed that only one support exists at each bent. The research team was interested in studying the effect of changing the diaphragm stiffness to simulate the development of cracks in the diaphragm and its effect on the response of the bridge.
- Only typical AASHTO type girders (I through VI) could be analyzed using RESTRAINT. If the dimensions of the girders in a specific project or the strand layout do not conform to the standard AASHTO configurations, RESTRAINT cannot be used for the analysis. Furthermore, the strand layout is used for all spans regardless of the span length.

Modified Program mRESTRAINT

Because of the limitations listed in the previous section, the research team developed a modified version of the program mRESTRAINT. The modified program addresses all the aforementioned limitations and is part of the deliverables of this project. APPENDIX B presents a summary of the introduced modifications. It should be noted that mRESTRAINT range of analysis has been extended for girder ages up to 20000 days (about 55 years).

The major challenge in modifying the program was introducing the unsymmetric configurations. Symmetry simplifies the analysis considerably, which is suitable for a spreadsheet application. Because of the complexity of moment calculations for unsymmetric

general configurations, the introduced modifications were programmed in Visual Basic for Applications (VBA) within the spreadsheet. VBA is used in the original RESTRAINT for the graphical user interface (GUI). In mRESTRAINT, VBA code was added to calculate the restraint moment as a replacement to the spreadsheet calculations that limit its applicability. mRESTRAINT is an open source program and the additional code can be viewed from within Microsoft Excel.

Parametric Study

A parametric study was conducted to analyze different bridge configurations for the purpose of estimating the restraint moment, M_r . The results from the study were used to understand how each of the investigated parameters affected the development of the restraint moment. Based on these results, it was possible to establish minimum girder age such that a certain performance criterion (acceptable level of restraining moment, $M_{r,a}$) can be met.

In choosing the parameters to be included in the investigation, information published in the literature was used. The identified parameters were: (1) girder age at the time of introducing continuity and (2) stiffness of continuity diaphragm. In addition to these two parameters, the bridge configuration was also covered by studying cases with (3) different number of spans and (4) different span length ratios. Although mRESTRAINT is capable of analyzing bridges with up to 5 spans, only 2 and 3-span bridges were covered. The justification behind limiting the number of spans to 3 is that the effect of additional spans becomes negligible on the continuity detail in question. The diaphragm stiffness, which is represented by its moment of inertia, I_d , is varied over a wide range. An uncracked diaphragm would have I_d equal to the gross moment of inertia, I_g , of the girder's cross sectional dimensions. If the diaphragm is completely damaged, I_d would be taken equal to zero. NCHRP Project 12-53 recommends that the age of continuity be taken equal to 90 days. Therefore, the range of this parameter was varied around that value. Table 4 lists the range of parameters covered in this study. A total of 120 cases were considered. They are designated with names that reflect the parameters for each case. For example, 2S-0.75R-0.5D-180C denotes that the number of spans (S) in the bridge is two with their span lengths ratio (R) of 0.75:1, ratio of diaphragm stiffness (D) equal to 0.5, i.e. $I_d = 0.5 I_g$, and the corresponding age of continuity (C) is 180 days. Figure 15 shows a sample plot for the results from one set of analysis in which the effect of age on continuity is clear. As the age of girder at the time of introducing continuity increases, the restraint moment decreases. If the continuity is introduced after 180 days, no

positive restraint moment is to be expected and the continuity diaphragm will be subjected to a negative restraint moment.

Table 4
Technical specifications of employed sensors

Parameter		Investigated Values				
Number of Spans		2	3	--	--	--
Span Length Ratio	2 Spans	1 : 1	0.75 : 1	0.50 : 1	--	--
	3 Spans	1 : 1 : 1	1 : 1.5 : 1	1 : 2 : 1	--	--
Diaphragm Stiffness I_d		I_g	$0.50 I_g$	$0.25 I_g$	$0.125 I_g$	$0.05 I_g$
Age of Continuity (days)		28	60	90	180	--

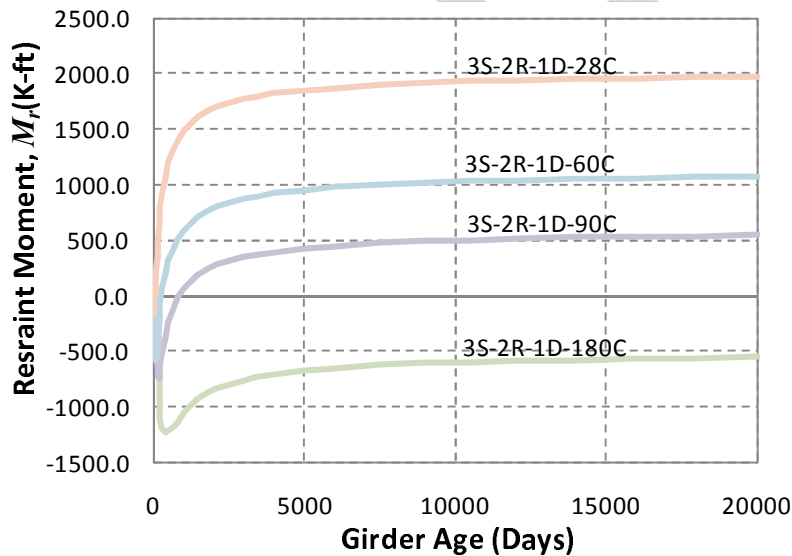


Figure 15

One set of results showing the effect of age of continuity on M_r .

Methodology for Establishing Age of Continuity

The results from the parametric study were used to better understand the required girder age at which continuity can be introduced such that a prespecified restraint moment value is not to be exceeded. To limit cracking in the continuity diaphragm or girder ends due positive restraint moments, acceptable restraining moment, $M_{r,a}$, values were considered. In addition to the maximum design moment value recommended in NCHRP Report 322 (I)

$M_r = 1.2 M_{cr}$, lower values were considered. These are 50%, 25%, 10%, and 0% of the cracking moment, M_{cr} . Two values were considered for the cracking moment. The first is related to the diaphragm's material properties and is calculated using the following formula:

$$M_{cr} = \frac{f_r \cdot I_g}{y_t} \quad (1)$$

where f_r = Modulus of rupture for the diaphragm's concrete

I_g = Moment of inertia of the girder

y_t = distance from neutral axis to the top of the girder.

P_e = Prestressing force

A_g = Area of the girder

e = eccentricity

Another value for the cracking moment was also considered based on the properties of the prestressed girders. This value was used to determine appropriate continuity age that would not cause the girder ends to crack. Cracking at ends of prestressed girders is a serious issue especially if it takes place in the bottom flange. It could lead to loss of anchoring of the prestressing strands, which may adversely affect shear capacity at this critical location. Because of the existence of prestressing forces in the girder the following formula was used:

$$M_{cr} = \left[\left(\frac{f_r \cdot I_g}{y_t} \right) + \left(\frac{P_e \cdot I_g}{A_g \cdot y_t} \right) + P_e \cdot e \right] \quad (2)$$

where P_e = Prestressing force

A_g = Area of the girder

e = eccentricity

In determining M_{cr} for prestressed girders, the effective prestress value is calculated at a transfer length of 4 in. from the girder end, which corresponds to the face of the diaphragm assuming that the girders are embedded 4 in into the diaphragm as is the case for Bridge #2. The rate of prestress transfer is assumed to be linear for each case (Nilson 1987) as shown in the Figure 16.

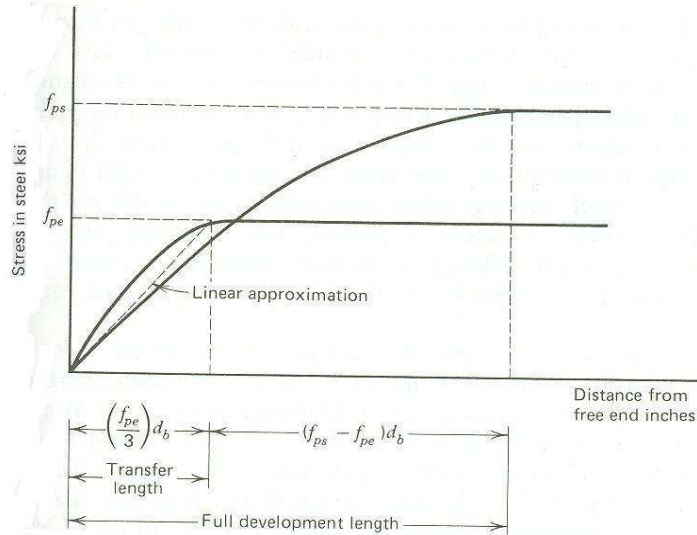


Figure 16
Transfer length model used in estimating M_{cr} at girder ends (Nilson 1987)

The transfer length (l_t) of the girder is calculated using the following equation:

$$l_t = \left(\frac{f_{pe}}{3}\right) d_b \quad (3)$$

where d_b – diameter of prestress strand

f_{pe} = effective prestress

Once the cracking moment is determined, the preset acceptable positive restraint moment, $M_{r,a}$, is used to determine the age at which this moment level intercepts with a curve that represents the results for the same case with different continuity ages. This approach is shown in Figure 17. In the figure, three curves for the 2S-1R-1D, 2S-0.75R-1D, 2S-0.5R-1D cases are plotted. For an assumed $M_{r,a}$ value (horizontal dashed line), the horizontal line intercepts the three curves at approximately 48, 57, and 75 days (marked with a star on the x -axis). This approach is repeated for all analyzed cases. The results are then studied to evaluate the 90-day recommendation in NCHRP Report 322. More details about the approach and the results can be found elsewhere (35).

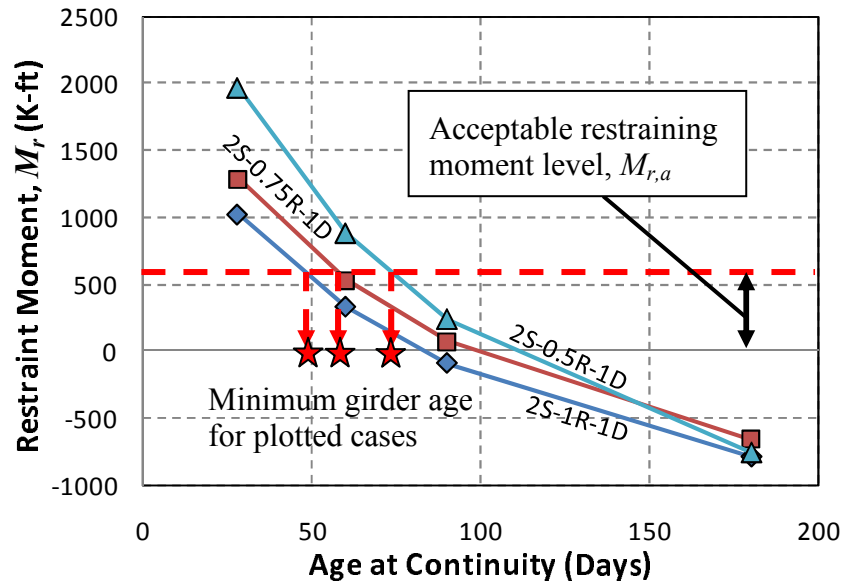


Figure 17
Determining girder age that achieves prespecified M_r criteria.

DRAFT

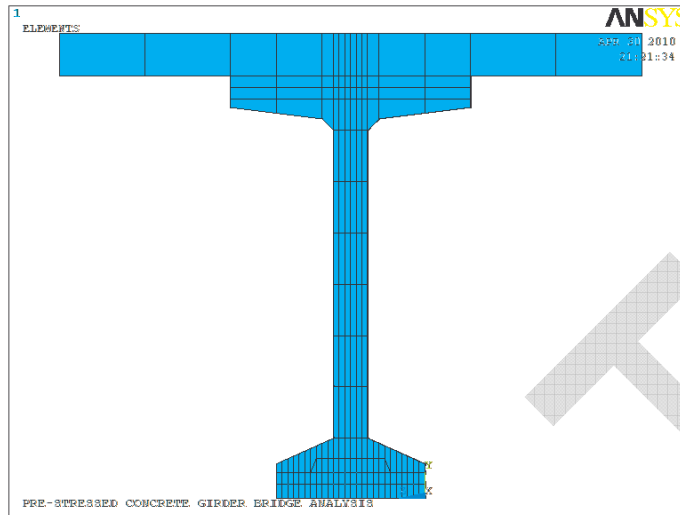
Finite Element Models

Finite element analysis software ANSYS (36) was used to model and analyze the behavior of Bridge #2. This section briefly describes the models that were used in the analysis. Material parameters used for different elements are also discussed here. The modeling of the material properties and boundary conditions are also described here. Details of the element types used in the analyses can be found in APPENDIX .

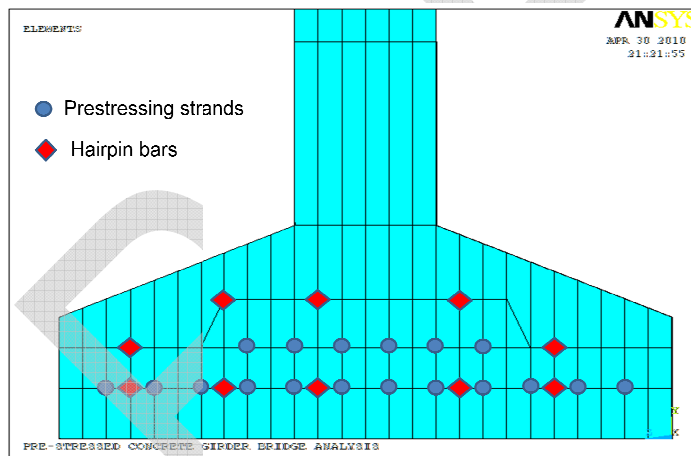
Three models were built for this study. The first model is a global bridge model in which all three spans and five girders are modeled. This model is used for analyzing the global behavior of the bridge. The second model is the single girder model where all three spans are modeled, however, only one of the girders is analyzed. This model allows for more details in the analysis (e.g. sequence of construction) and is used to study the transfer of forces between girders in adjacent spans. A third more detailed model is the joint model. This very fine model focuses on one joint which allows the use of a finer mesh. It is used to study the stress distribution on a smaller scale than the previous models. All three models are described next.

Single-line Girder Model

The meshing of the girders in the cross-sectional view can be seen in Figure 18. The girder is modeled in such a way that the prestressing strands and the hairpin bar coincides with the boundary of the concrete element. A perfect bond assumption is implied since both concrete and reinforcement (strand and bar) elements share the same node. The location of the prestressing strands and the hairpin bars is shown in Figure 18-b. Figure 19 shows a single-girder line model for Girder G3 where the middle span length is 101 feet and the exterior spans are 70-feet long. It can be seen that at the girder ends, a finer meshing is adopted to enhance the quality of the results where they are needed.



(a) Whole section



(b) Bottom flange showing reinforcement

Figure 18
Meshing of cross section

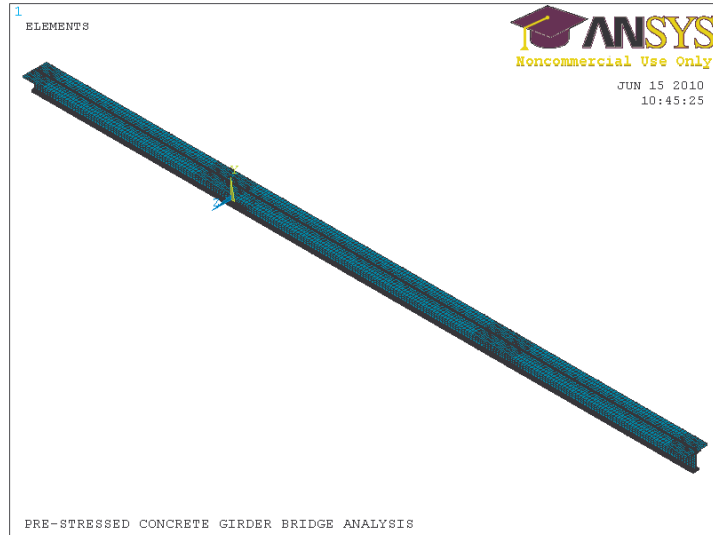


Figure 19
Centerline model for Girder G3.

Material properties: The bridge model is intended for elastic analysis. For this linear elastic material properties are used here both for the concrete and for steel. The concrete strength for the bridge is different for different components. That is the strength of the concrete for the girder is not the same as for the deck and diaphragm. The input parameters for the concrete were the 28th day's compressive strength, modulus of elasticity, the Poisson ratio and the density of the concrete. The coefficient for thermal expansion of concrete is also used as an input parameter. However, the thermal conductivity and the specific heat of concrete are also used as an input parameter for thermal physics environment. Material properties for the prestressing steel and the hairpin bars were the elastic modulus and the Poisson ratio. Prestress is applied as an initial strain in the real constant parameter. Coefficient of thermal expansion is also used as an input parameter for temperature loading. For the thermal physics environment, the thermal conductivity and the specific heat are used as input parameters for the steel.

Boundary constraints: After modeling the bridge, proper boundary conditions are applied to obtain the desired responses. The ends of the girder rest directly over the bent with or without the bearing pads. Thus a vertical reaction component develops there. Again to make the girder end continuous, diaphragms are poured in between the girder ends. In the model the girder end nodes are constrained in the y-direction, preventing its movement in the vertical

direction. However, to make the structure stable, a single node at the end of one girder is pinned, that is both the longitudinal and the transverse direction movement is restrained.

Two different physics environment were used in the analysis; the thermal and the structural. The full scale bridge was modeled before applying the thermal load on it. In this step the temperature is applied at the node in different location following the AASHTO thermal gradient. The value of the temperature applied is taken from the actual thermal reading from sensors. Depending on the material properties and thermal conductivity, ANSYS solves the model for temperature and gives the results as a nodal temperature for each element. The solution is then stored in a result file, which is later called in for subsequent use in other loading steps.

In the structural physics environment the loading is applied in such a way that it represents the actual construction sequence takes place in the site. The same full scale bridge model is used for loading in these steps. In the first loading steps to incorporate the girder prestress and self weight, the deck, haunch and the diaphragm are made inactive, and the prestress and self weight is applied to the girder only. In actual practice, for shored construction the in place girder acts as a support for the deck and haunch concrete to be cast. Thus the weight of the wet concrete is taken entirely by the girder as if additional dead load is applied onto the girder. To capture this phenomenon, equal amount of loading is applied onto the girder in the following steps. When the concrete gets hardened, it then acts as a composite bridge. Thus any additional loading is taken by the composite action of the bridge. To capture this, in the next loading steps the deck, haunch and the diaphragm are reactivated with the material having negligible density, so that no other additional dead load is applied in the already applied loading steps. The superimposed dead load is applied after the deck concrete is hardened and the whole bridge acts as a composite. Thus in the next loading steps the additional superimposed dead load is applied over the deck. In the following loading steps the temperature load is applied to the whole bridge structure. To do this the results file created at the physics environment is called in at this steps and solved for thermal loading. In this way the whole construction sequence loading is applied to the bridge. Once the bridge is complete it is then subjected to the live loading. To capture the live load effect, in the following loading steps live load is applied and solved.

Global Bridge Model

This model is a full representation of the entire bridge. It is basically a five single-line girder model attached to each other. Each girder line has different span lengths, thus allowing for proper representation of the skew. The same element types used in the single-line girder model are also used in the global model. Figure 20 shows the finite element mesh of the global bridge model. Construction sequence was not accounted for in analyses conducted using this model. This simplification does not affect the quality of the results obtained using the global model since it was mainly used to study the effects of superimposed loads (e.g. live load cases). As such the stress buildup prior to the application of the superimposed loads was not of interest in these analyses.

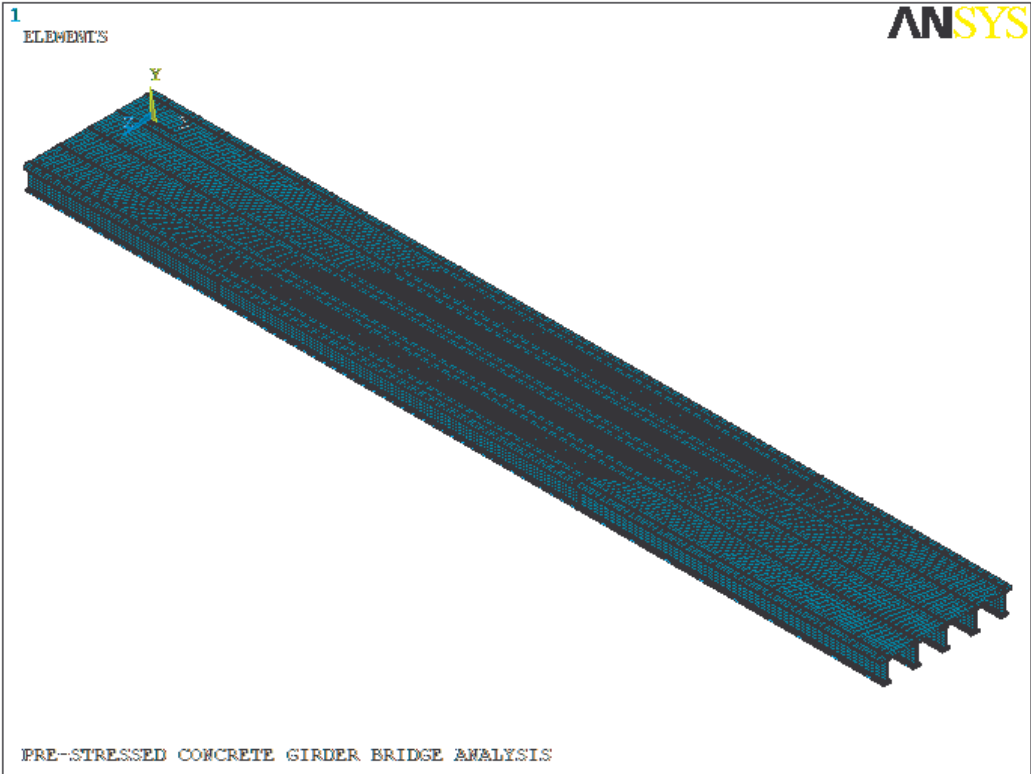


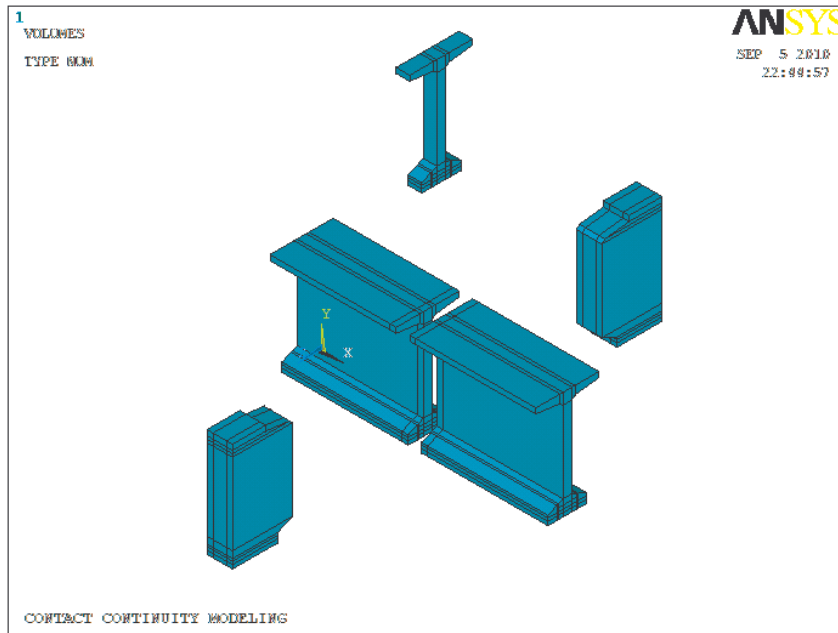
Figure 20
Global model for Bridge #2.

Joint Model

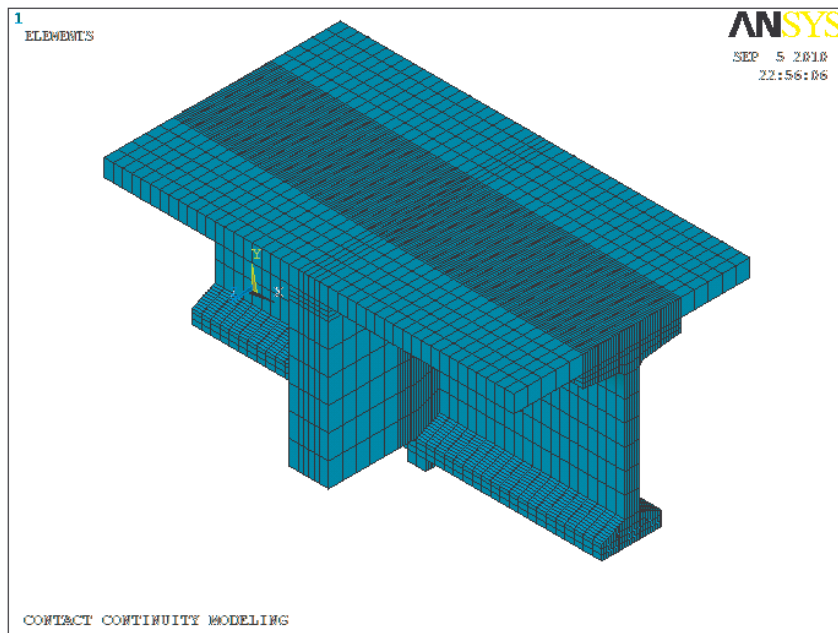
To better understand the actual response of the hairpin bar under different types of loading without the need for unreasonable computing resources, a segment of the girder ends including the diaphragm is modeled separately. The segment of the girder at each end is taken equal to the height of the section from bottom of the girder to top of the deck. The actual construction sequence leads to the development of a cold joint at the interface between the girder ends and diaphragm. Therefore a close contact exists at the interface and element CONTA178 is used to model this contact having two nodes at the same location, one on each side; i.e. girder element and diaphragm element. CONTA178 element is used to join these two nodes. This requires creating and meshing separate volumes that can be later moved adjacent to each other as can be seen in Figure 21.

The girder ends are supported on bearing pads that also modeled using SOLID45 elements. The transverse diaphragm is extended both sides up to a distance of center to center of the girder spacing. The boundary condition for the transverse diaphragm is applied in such a way that the diaphragm is restrained in the z (transverse) direction, while being free to move in the x (longitudinal) and y (vertical) directions. The hairpin bar is modeled in such a way that the hairpin bar from the opposite girder enter into the diaphragm in an alternate way. The prestressing transfer length is introduced into the model by changing the initial prestressing strain linearly starting at the girder ends following the assumption made earlier

(Equation 3) $l_t = \left(\frac{f_{pe}}{3}\right) d_b$ (3 for a linear l_t relationship).



(b) solid volumes before meshing



(b) finite element mesh

**Figure 21
Creation of detailed joint model.**

Live Load Test

The research team conducted a live load test on the monitoring segment to assess the details performance under truck loads. Both static and dynamic tests were carried out. Since the installed monitoring system is designed to capture long-term performance, it is not suitable for capturing fast changing readings due to moving loads. Therefore, additional sensors were installed for that purpose. The live load tests took place on August 19, 2010 after installing the additional sensors on August 18, 2010.

In this section, the live load setup is described and details about the additional sensors are provided.

Truck Description

Two trucks were acquired for the load test from the LA-DOTD maintenance office in New Roads, LA. Both trucks were dump trucks and were loaded before the tests. The Gross Vehicle Weight (GVW) for the first truck (Truck #1) was measured to be 57.0 kips and the second truck (Truck #2) was slightly lighter at 54.1 kips. Detailed axle dimensions and weights were also measured and can be found in APPENDIX . The trucks were used in tandem for all the static cases, while only one truck was used at a time for the dynamic load test. It should be noted that the total weight of both trucks is substantially under the design load according to AASHTO-LRFD (37) for the bridge configuration on hand. Nevertheless, the combined weight is considered suitable for achieving the goals of this task.

Static Load Tests

The first set of tests was static in nature. Both trucks were used in tandem in prespecified loading position that would generate maximum effects intended for the study. A loading plan was submitted to the PRC for approval prior to conducting the tests. The approved plan entailed nine loading positions. The first six loading positions targeted the generation of maximum positive moments at midspans of the tested segment, hence the 'P' designation for these cases. Another three loading positions were chosen for the purpose of generating the maximum negative moments at the monitored continuity diaphragm, hence the 'N'

designation for these cases. These positions were determined using finite element (FE) analyses using a sweeping technique of truck loads until the position that would generate the maximum targeted behavior is identified. Based on these FE analyses, the distance from a fixed reference was identified and used in the marking process. Table 5 lists a summary of the static live load test positions, the spans on which the trucks were loaded, and the targeted behavior. Despite the fact that the monitored bridge carries traffic in both directions, trucks were positioned as shown in Figure 22 for all considered cases. This minor variance from real life traffic is not significant since the important factor is the center of gravity of the applied load.

The approved live load test plan was then executed by first marking the bridge deck with the truck locations as can be seen in Figure 23 for three of the tested positions (P1, P4, and N2). The marked location indicated the position of the center of the rear axle for a two axle assumed truck. As mentioned earlier, the rate of data recording is 24 readings per minute which are then averaged and stored for retrieval. This rate translates into one reading every 2.5 minutes. To ensure that more than one data point is collected for each static load position, the trucks were asked to stay at each position for a period equal to or longer than 11 minutes. During this period at least 3 and probably 4 readings were recorded for each loading case. In between loading positions P1 and P2, P3 and P4, P6 and N1, N1 and N2, and N2 and N3, the trucks were driven off the tested bridge segment to help in determining a reference datum for the recorded readings. Figure 24 shows the actual trucks in two of the static loading positions; namely P1 and N1.

The research team recorded the time at the beginning and at the end of each loading case from the logger's clock. These times are essential for associating the recorded data with the proper loading case.

Table 5
Description of static live load positions

Position	Loaded Span(s)	Targeted Action	Effect on Continuity Detail
P1	23	Positive moment at midspan – G3-G5	Closing – One side
P2	24	Positive moment at midspan – G3-G5	Closing – One side
P3	25	Positive moment at midspan – G3-G5	Open – One side
P4	23	Positive moment at midspan – G1-G3	Closing – One side
P5	24	Positive moment at midspan – G1-G3	Closing – One side
P6	25	Positive moment at midspan – G1-G3	Open – One side
N1	23 & 24	Negative moment at Bent 24 – G1-G3	Closing – Both side
N2	23 & 24	Negative moment at Bent 24 – G2-G4	Closing – Both side
N3	23 & 24	Negative moment at Bent 24 – G3-G5	Closing – Both side

DRAFT

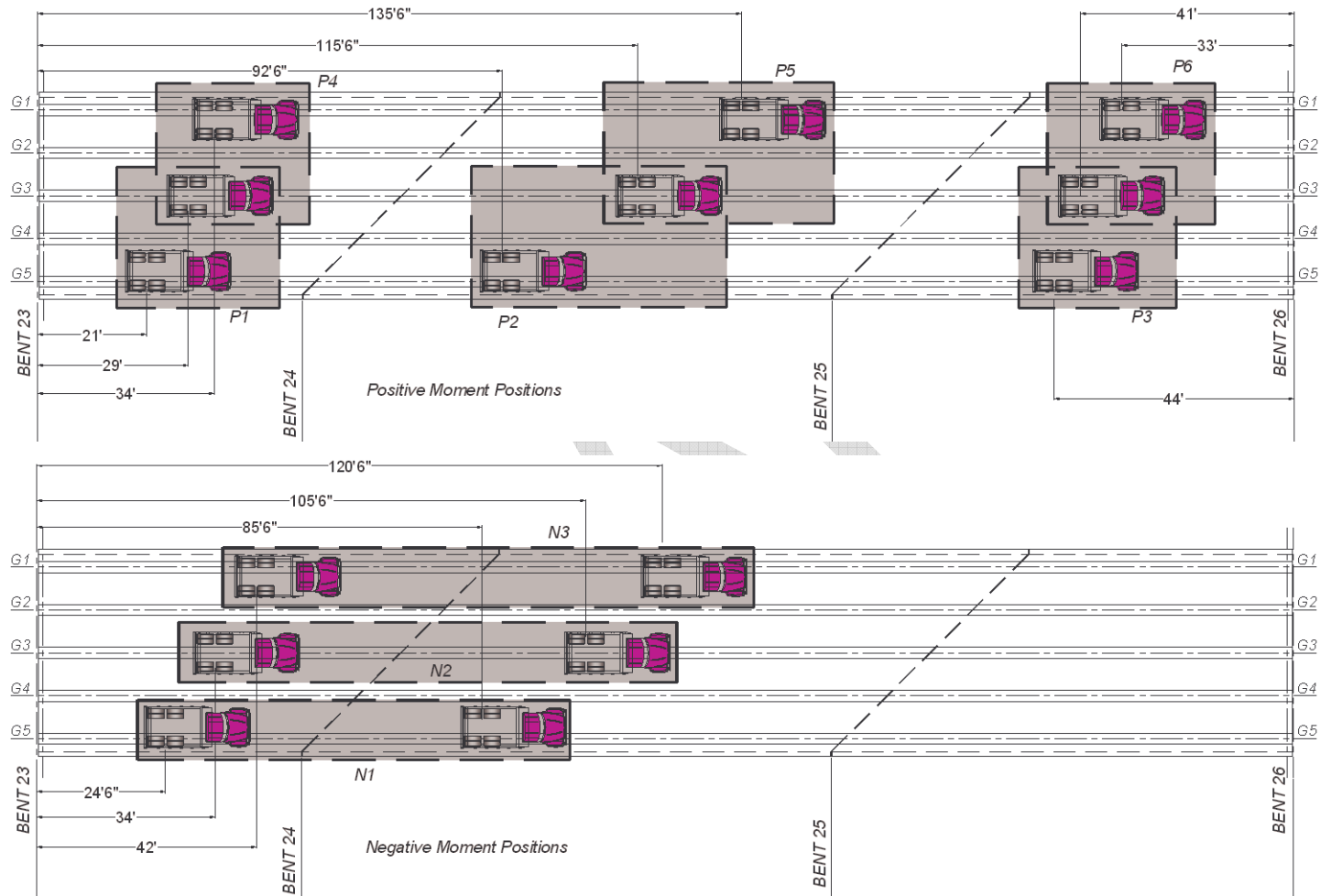


Figure 22
Load test truck positions (distance with reference to middle of rear drive axle – see Figure D-2).



Figure 23

Marking the bridge deck at truck positions for static live load test.



(a) Position P1



(b) Position N1

Figure 24

Actual Trucks #1 and #2 in position for two of the nine static load positions.

Additional Sensors for Dynamic Tests

...

...

...

...

Dynamic Load Tests

Dynamic loading tests were performed on three traffic lanes using both Truck #1 (heavier one) and Truck #2 (lighter one). Due to the limitation of site conditions, the truck speeds are low as described below. Since the bridge was not yet open to traffic, the actual traffic lanes were not striped at the time of conducting the load test. The lane definition and truck positions for this discussion are defined as:

- Path A (left lane): the left tire is about 6 feet from the left curb
- Path B (center lane): the truck is at the center of bridge
- Path C: (right lane): the right tire is about 6 feet from the right curb

Figure 25 shows the truck driven paths during the dynamic load tests. Three dynamic tests were conducted:

- Dynamic Test 1: The Truck 2 (34 mph) followed by Truck 1 (30 mph) in lane 2 (center lane). The two trucks are not on bridge at the same time.
- Dynamic Test 2: The Truck 2 (34 mph) followed by Truck 1 (31 mph) in lane 1 (left lane). The two trucks are not on bridge at the same time.
- Dynamic Test 3: The Truck 2 (34 mph) followed by Truck 1 (34 mph) in lane 3 (right lane). The two trucks are not on bridge at the same time.

Before the dynamic test, three crawling tests corresponding to the dynamic test with a truck speed of about 3 mph were conducted. The truck positions were intended to be the same as dynamic tests. However, truck positions in dynamic test are more difficult to control. In the crawling tests, the Truck 1 was followed by Truck 2. The two trucks are not on bridge at the same time.

- Crawling Test 1: The Truck 1 (3 mph) followed by Truck 2 (3 mph) in Path A. The two trucks are not on bridge at the same time.
- Crawling Test 2: The Truck 1 (3 mph) followed by Truck 2 (3 mph) in Path B. The

two trucks are not on bridge at the same time.

- Crawling Test 3: The Truck 1 (3 mph) followed by Truck 2 (3 mph) in Path C. The two trucks are not on bridge at the same time.

DRAFT

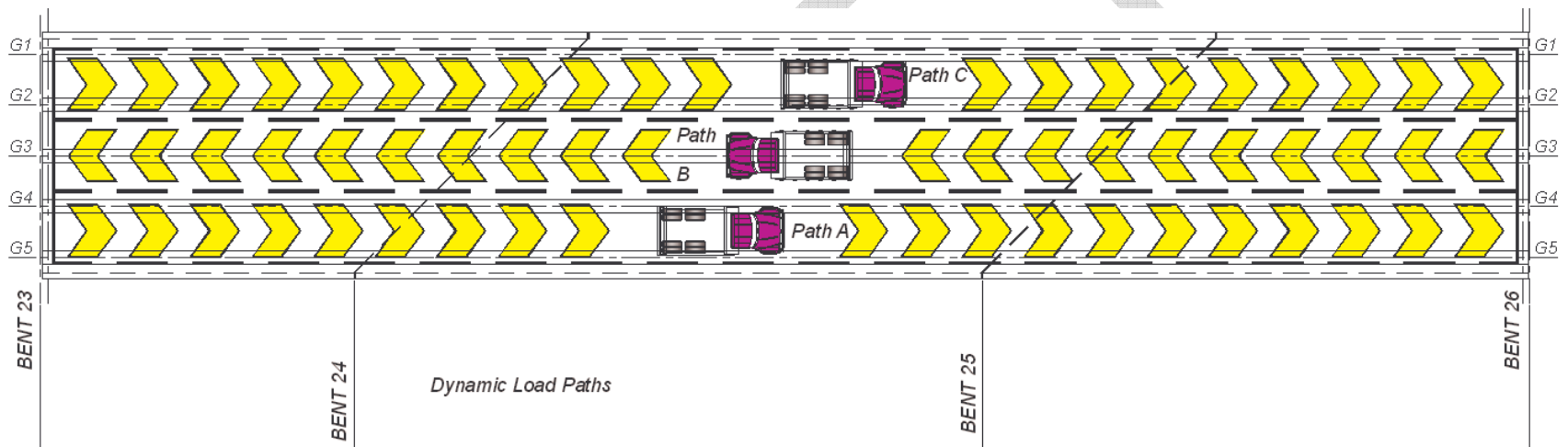


Figure 25
Truck paths for the dynamic load tests.

Temperature Effect

During the course of the static load tests which started at 9:00AM and continued until about 2:30PM, the temperature at the bridge site rose about 10 °F. This rise in temperature affects both sensor readings and structural response. While the first is correctable using the temperature correction formulas provided by the sensor manufacturer, the second is real and will have to be discounted from the recorded readings. More important is the temperature gradient whose effect on the continuity detail is more severe since it causes the bridge to camber up, hence applying an opening action on the joint. In comparison to temperature gradient effect, uniform temperature change applies uniform extension or contraction on the bridge girders and hence the joint. Figure 26 shows a plot of the temperature rise from five deck sensors and three bottom girder sensors. It should be noted that the five deck sensors are at a depth of about 6 inches from the deck surface. Temperatures above 110 °F were recorded manually by the research team on the deck surface during the course of the static load test.

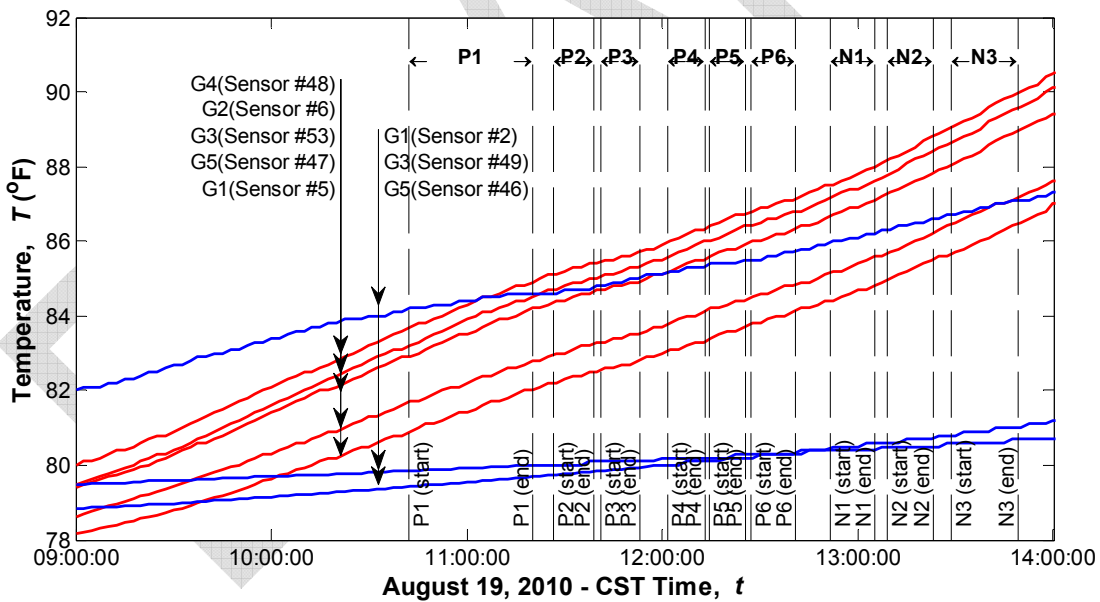


Figure 26
Temperature increase during the time of conducting static load tests.

Because of the aforementioned temperature changes, sensor readings kept changing as a result of the thermal movements of the structure. Identifying the appropriate datum from

which the effect of the static live load are to be measured was carefully studied. The identified datum was identified with the help of the six periods where the trucks were driven of the bridge. The following section shows a sample sensor reading for illustration purposes. Plots of all sensor readings during the static live load tests can be seen in APPENDIX .

Sample sensor reading

All sensor readings were acquired at the highest rate allowed by the monitoring system for the static load cases (1 reading / sensor / 2.5 minutes). The first step in the data processing was to correct the readings for temperature effects with respect to the initial reading at the beginning of the test, which was taken to be 9:00AM on August 19, 2010. Once the data was corrected for the temperature effect, periods when no trucks were present on the bridge were identified. A fictitious line was drawn to connect the average readings during each one of the six 'No Load' periods to serve as the temperature adjusted datum.

Figure 27 shows a sample plot for one of the strandmeters installed on the hairpin bars in G3 of Span 23 (Sensor #50). Two plots are shown for the sensor strain readings. The first one (dashed line) is for the raw readings before temperature corrections, while the second plot which is marked by squares represents the temperature corrected readings as per the manufacturers recommendations.

The first observation from this figure is that the temperature rose about $400 \mu\epsilon$ by the end of the static load test (2:00PM) relative to the starting time (9:00AM) not considering the truck effects. This leads to an apparent erroneous increase in strains for all loading cases regardless of whether they cause positive or negative moments at the location of the sensor. After identifying the No-Load periods on the chart, an adjusted datum can be constructed as shown in the figure. As can be seen, this temperature-adjusted datum intersects with the sensor readings more than once. The difference between the temperature-adjusted datum and the temperature-corrected sensor readings is the relative sensor reading. It is clear that some load cases cause positive strains (opening action), while the majority cause negative strains (closing action). In the figure, the relative sensor reading during the P2 load case is clearly identified. The result is a negative strain of about $-47.7 \mu\epsilon$. A positive strain of about $+18 \mu\epsilon$ can be identified for the P3 load case. It should be noted that P2 causes a negative moment at this sensor location, while P3 causes a positive moment at the sensor location.

The approach described in this section was used to interpret the live load static test readings for all sensors. The results are plotted in APPENDIX . A summary of the relative sensor readings are given in TABLE XXX, which shows that many of the readings are small because of the nature of the sensor location (close the neutral axis) or its proximity with respect to the loading position. To ensure the reliability of the interpreted data, a minimum threshold, $\epsilon_{\text{threshold}}$, was established. All sensor readings below this threshold were considered too small to warrant consideration in analyses. These readings are identified by '<<<' in Table XXX.

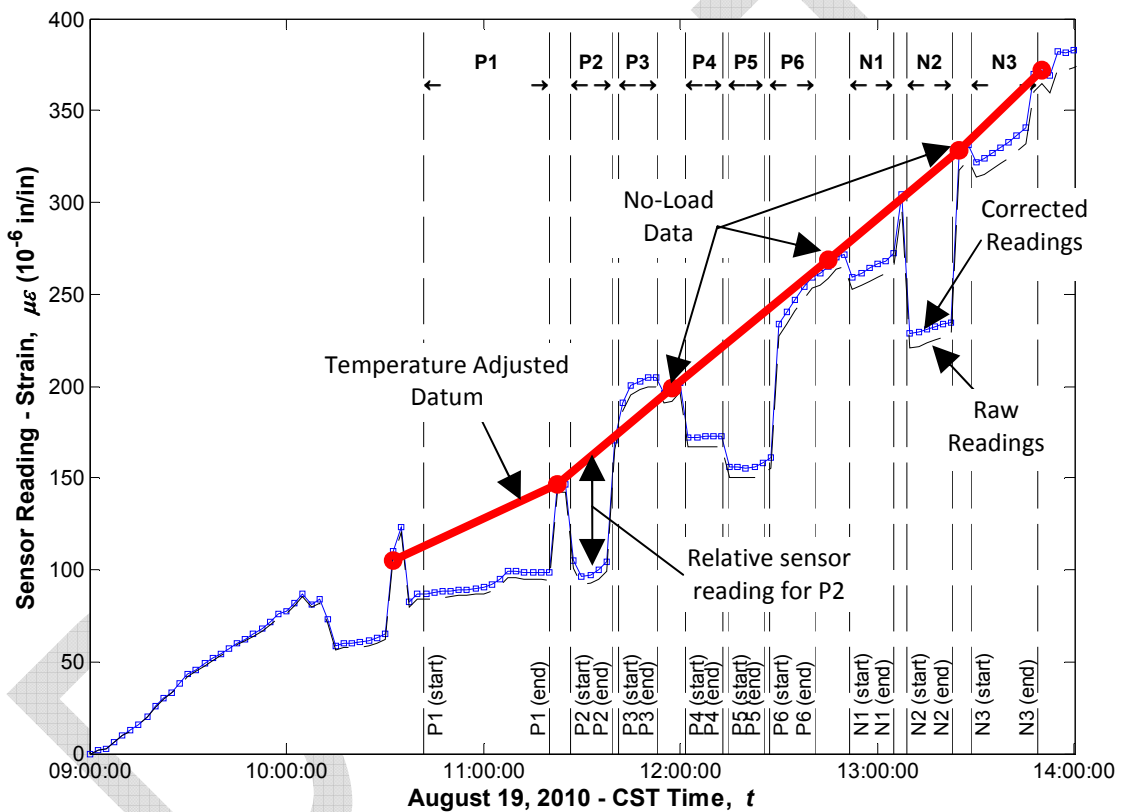


Figure 27
Sample sensor reading during static live load testing (Sensor #50 – G3, Span 23, hairpin bar).

DRAFT

DISCUSSION OF RESULTS

In this section, the results from all approaches described in the METHODOLOGY section are presented. An enormous amount of results has been obtained over the period of the project. In this section, the key results that are pertinent to the objective of the project will be presented.

Structural Health Monitoring Data

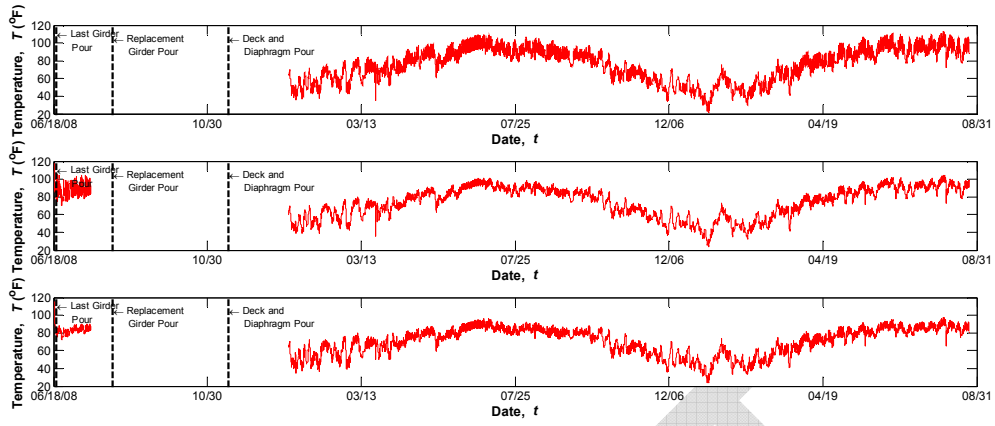
Temperature Data

Each of the installed sensors (embedded and surface-mounted) records two readings. The first is the response reading for that sensor type (e.g. strain for sisterbars) and the second is the temperature at the location of the sensor. As such, plots of the temperature at the monitored locations is possible over the entire length of the monitoring period including the curing period at the casting yard for some of the girders. In many monitored sections, there are several sensors across the height of the girder. This means that data temperature gradients can also be plotted. This section presents the results for the three sections in Girders G3, G4, and G5 at midspan.

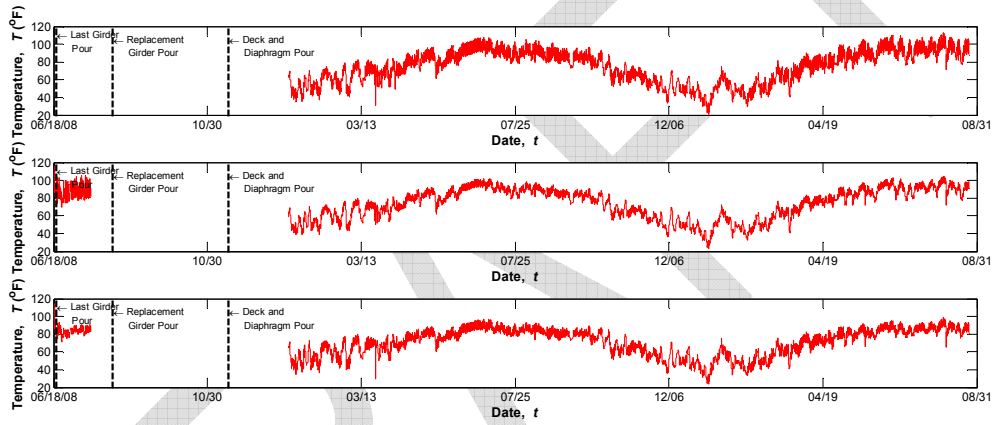
Figure 28 shows the temperatures at midspan sections of G3, G4, and G5 in Span 24 at three locations, namely deck, top girder flange, and bottom girder flange. It can be seen that the seasonal changes cause a huge temperature fluctuations from a minimum of about 20°F to 115°F. The highest temperatures are always recorded in the deck because of the direct exposure to sunlight. Sunlight exposure also causes larger daily variations in the deck than the other sensors as evident by comparing the range of daily amplitude from deck and girder flanges. The only exception to this general statement is the bottom flange sensor in Girder G5. Daily variations at that location are higher than those at the other bottom flanges. This phenomenon puzzled the research team until it was noticed that G5 gets exposed to sunlight since it is an exterior girder. This observation will help explain many of the different observations associated with Girder G5. It should also be noted that while on site, the research team checked the on the shaded parts of the deck surface and compared to sunlit parts of the deck surface using a laser gun device. The difference in temperature between these two location on the deck surface was about 10-15°F. Therefore, the bridge railing next

to Girder G5 casts its shade on the top of the girder while the bottom flange is heated by direct exposure to sunlight.

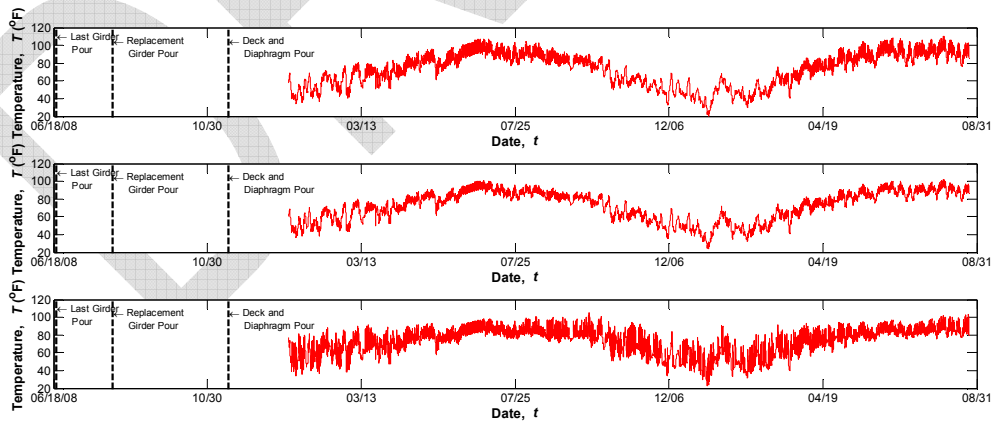
These temperatures are also used to plot a representative temperature gradient by subtracting the bottom flange temperature readings from the deck temperature readings. The temperature gradient plot in Figure 30 is for G3. It shows that the difference in temperature between the deck sensor and the bottom flange is as high as +16 °F and as low as a -7 °F. It should be noted that the deck sensor is installed on the bottom layer of deck reinforcement, which means that the deck surface temperature is even hotter. This means that the actual temperature gradient can easily exceed 20°F. Such a high temperature gradient can cause the structure to undergo substantial deformations, especially if it is a large structure such as a bridge.



(a) Girder G3



(b) Girder G4



(c) Girder G5

Figure 28
Temperature readings in deck, top and bottom girder flanges.



Figure 29
Sunlight hitting the bottom flange of G5 while the top flange is shaded by the overhang.

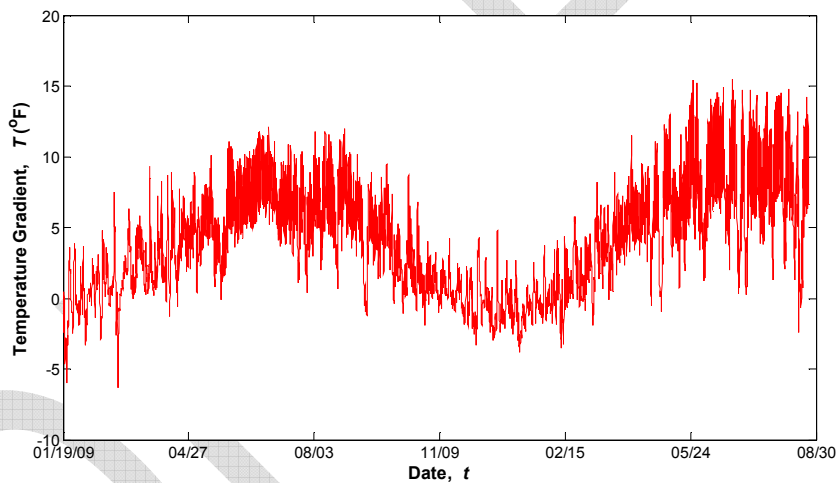


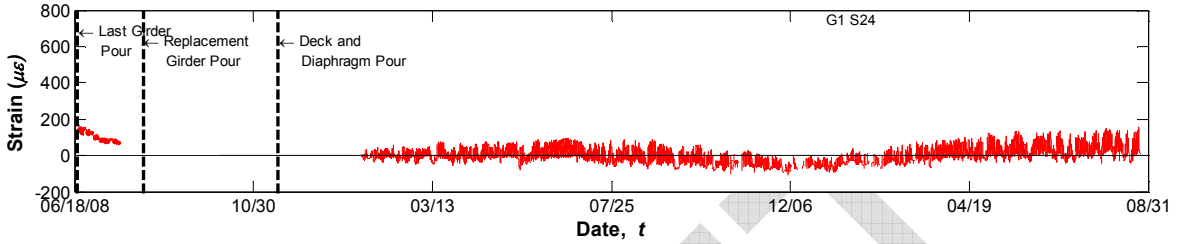
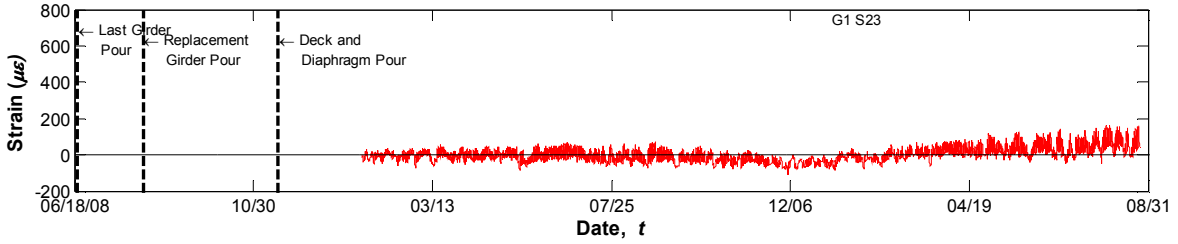
Figure 30
Temperature gradient (Girder G3 in the middle of Span 24).

Strains in Hairpin Bars

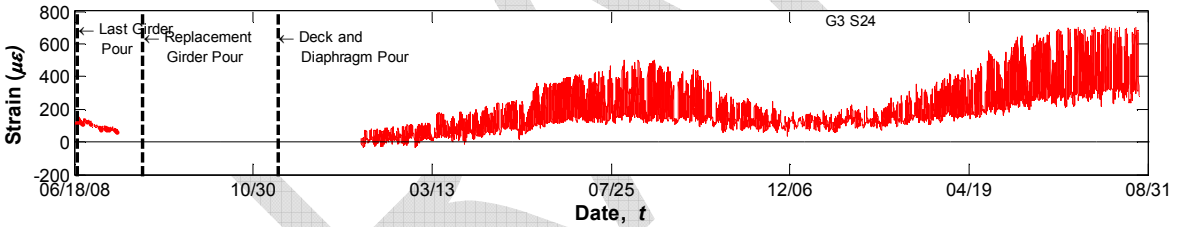
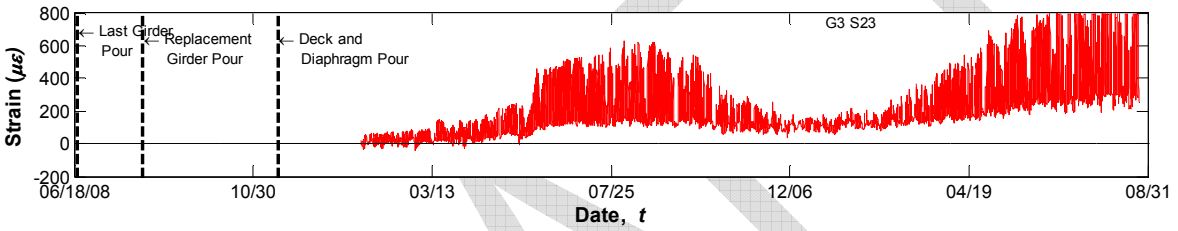
Strains from the hairpin bars are presented in this section for all three monitored joints connecting Span 23 and Span 24 at Girders G1, G3, and G5. No strandmeters were installed on the hairpin bars in Girder G5 in Span 23 as mentioned earlier. At each monitored location, two strandmeters were installed. The average of both readings is used as a representation of the condition in the hairpin reinforcement. Figure 31 shows two plots for monitored joint. The top and bottom plot for each girder represent the strain in the hairpin bars installed on the Span 23 side and the on the Span 24 side, respectively. As can be seen from the plots, the

recorded strains from Girders G1 and G5 are similar in behavior. The daily range of fluctuations is about 100 microstrains ($\mu\epsilon$). This can be added to a seasonal change (difference between low temperature in winter and low temperature in summer) in strains of another 100 $\mu\epsilon$. The behavior of Girder G3 is completely different. Seasonal changes of about 200 $\mu\epsilon$ can be seen between the low temperatures 12/06/2009 and 08/31/2010. Furthermore, the daily fluctuations are substantially higher for this girder as they are in the range of about 500 $\mu\epsilon$. This behavior was intriguing to the research team. After checking that the data processing is not the cause of the large difference between the strains in this girder and the other two, a visual inspection was conducted, which revealed that a crack developed in the bottom flange of Girder G3 – Span 24 at the interface with the continuity diaphragm. Figure 32 shows the crack when it was marked on May 5, 2009. The crack width was about 0.013 inch and barely visible because of its location. No cracks were found in the bottom flange of G3 on the other side (Span 23). However, the high strains indicate that the girder may be cracked in the embedded portion inside the diaphragm. A similar inspection of Girders G1 and G5 did not reveal cracks in the bottom flanges of these girders.

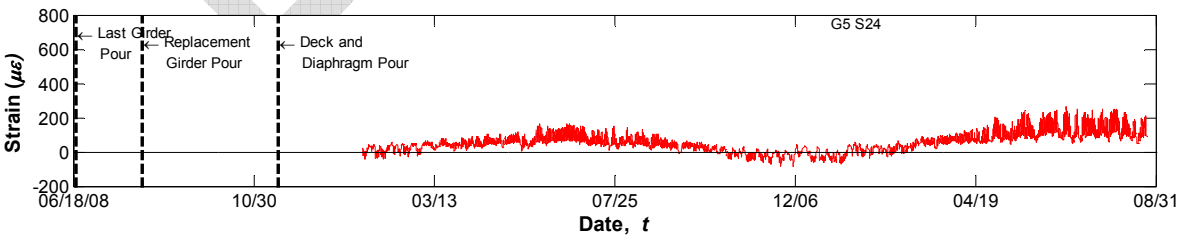
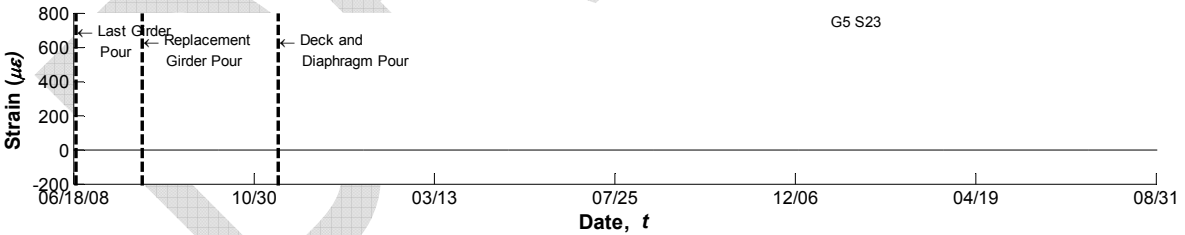
The strains at the girder's bottom flanges were also investigated to understand the dissipation of these high strains in the hairpin bars 18 inches away from the continuity diaphragm's face, which is where the vibrating wire gages are installed (top, middle, and bottom). Figure 33 shows the strain records from the surface mounted gages on the bottom flanges on Girders G1, G3, and G5 on both sides of the continuity diaphragm; i.e. Span 23 and Span 24. It can be seen that the daily strain changes are about 30-40 $\mu\epsilon$ for all locations except for Girder G3 (both sides) and Girder G1 (Span 24) where the daily strain changes are about 70-80 $\mu\epsilon$. By comparison with the readings from the strandmeters on the hairpin bars, the changes are much less in all cases. The drop in daily strain changes at the surface-mounted VW gages can be attributed to the fact the tensile force in the hairpin bars has been distributed into a larger area of the girder 18 inches from the diaphragm face. At girder ends, the hairpin bars are the sole resistance of tensile forces. Because Girder G3 is cracked at the face of the diaphragm, the tensile force is still mainly resisted by the hairpin bars. However, because no further cracks took place in the girder, the tensile force is effectively distributed into the girder. The high strain changes from the surface-mounted VW gage on Girder G1 (Span 24) is also higher than G5 and G1 (Span 23), which may indicate that a crack has taken place at this location. Visual inspection has not revealed any cracks at this location.



(a) Girder G1



(b) Girder G3



(c) Girder G5

Figure 31

Strains in hairpin bars at both sides of continuity diaphragm.



Figure 32
Observed crack at bottom flange of Girder G3 – Span 24.

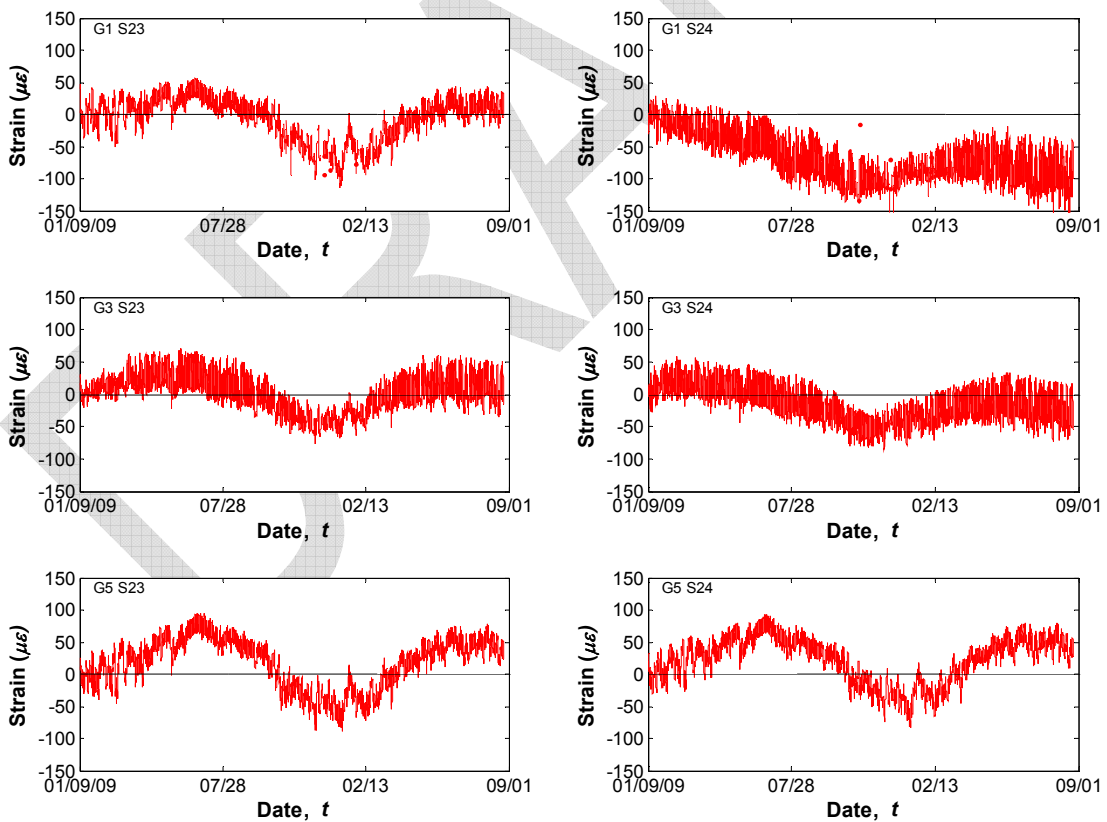


Figure 33
Surface-mounted VW strains at bottom flanges on both sides of continuity diaphragm (Girders G1, G3, and G5).

Relative Movement between Bottom Flanges in Adjacent Spans

The relative movement between the bottom flanges at ends of adjacent girders on both sides of the continuity diaphragm was investigated using the gapmeters (DM) installed at Girders G1, G3, and G5. Any displacement captured by the gapmeters would indicate the relative movement between the bottom flanges of the girders. Positive displacements mean that the distance between the bottom flanges have increased; i.e. the girder are applying tension on the diaphragm, and vice versa. Figure 34 shows a plot of the temperature corrected readings from all three gapmeters (DM), which were installed on Girders G1, G3, and G5 across the continuity diaphragm at Bent 24. It can be seen from the figure that Girders G1 and G5 experienced far less seasonal and daily changes than did Girder 3. This observation confirms the earlier discussions of the hairpin and vibrating wire strain readings presented earlier in light of the existence of a crack in Girder G3 (Span 24). Quantitatively, the gage lengths for these extended DM gages were 46.0 in, 43.0 in, and 45.5 in for Girders G1, G3, and G5, respectively. This means that if a joint was cast monolithic with the girders, the resulting daily strain changes would have been equal to about $0.0150/46=326 \mu\epsilon$, $0.0325/43=756 \mu\epsilon$, and $0.0175/45.5=385 \mu\epsilon$ for Girders G1, G3, and G5, respectively. Ofcourse, the cold joint between the precast girders and the cast-in-place diaphragm allow some movement, and the hairpin bars are not as efficient as if the positive moment reinforcement were coupled between both girders. Cracking in the diaphragm and/or the girders within the gage length also increases the displacement. Therefore, the strain readings recorded by the strandmeters on the hairpin bars and the surface-mounted VW gages are expected to be lower than this apparent strain from the gapmeters. It should also be noted that the daily changes are less in the cold months (December, January, and February) than in the summer. This is due to the smaller temperature gradients during cold months (see Figure 30), which in turn reduces girder rotations at the joint.

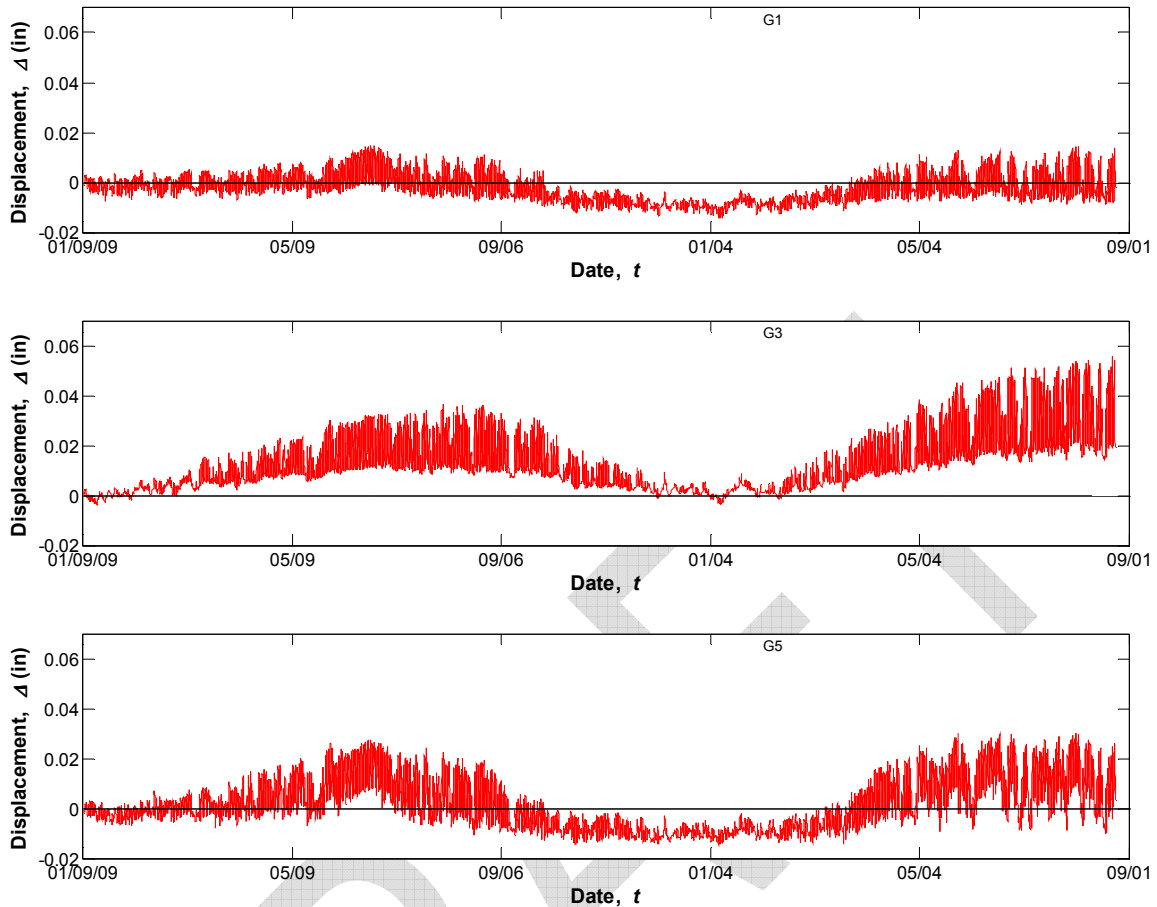


Figure 34
Gapmeter displacements for Girders G1, G3, and G5.

Differential Shrinkage between Deck and Girder Concrete

Of the several factors that cause long-term deformations in precast PSC slab-on-girder bridges, differential shrinkage between the cast-in-place deck and the precast girder is of interest. The ages of the girders at the time of introducing continuity are summarized in Table 6.

Table 6
Technical specifications of employed sensors

Girder	Girder Pour Date	Diaphragm Pour Date	Age at Continuity (days)
G3	6/18/2008	11/18/2008	153
G4	6/18/2008		153
G5*	8/9/2008		101

* Replacement girder

It can be seen that all girders exceed the 90-day girder age recommendation from NCHRP Report 519 (1). It can also be seen that the G5 replacement girder was younger by 52 days than the other girders in the monitored segment. Figure 35 shows plots from the sisterbars in the deck and top flanges at Girders G3, G4, and G5 locations. It can be seen that the deck strains are almost identical (decreased about $75 \mu\epsilon$ over the monitoring period) for all three girders since they all share the same reference point; i.e. time load was applied or deck shrinkage ensued. The girder top flange strains decreased about $100 \mu\epsilon$ for girders G3 and G4 during the same period. A lesser amount of about $50 \mu\epsilon$ is recorded for Girder G5. It should be noted that the shown strains are summative; i.e. they include the effect of deck shrinkage, creep due to prestressing forces, creep due to dead load effects and temperature changes. The latter are seasonal or daily events and can be easily seen in the plots. Therefore the discussed strains are the average strains to eliminate any daily temperature change effects. Isolating the differential shrinkage strains from the creep induced strains is not possible without making analytical assumptions. As such, it can be said that the combined effect of creep and shrinkage together presented in the shown plots. Girder G5, which was 101 days old at the time the continuity diaphragm was poured, would then have more upward (camber) movement due to prestressing creep than the other girders (G3 and G4). Therefore, the difference between the deck strain and the girder's top flange strains are different. The plotted strain records show that the difference between the deck and top flange strains ($\epsilon_{deck} - \epsilon_{girder}$) is about $-25 \mu\epsilon$ for Girders G3 and G4 and $+25 \mu\epsilon$ for Girder G5. While these differential strains may be considered minor, their trends confirm that girders age is a major factor in the performance of the continuity detail. It should be noted that the period between pouring the deck and continuity diaphragm (11/8/2008) and the date when the monitoring system was installed at the bridge site (1/9/2009) is 52 days when much of the initial deck shrinkage takes place. Unfortunately, no data is available from this period.

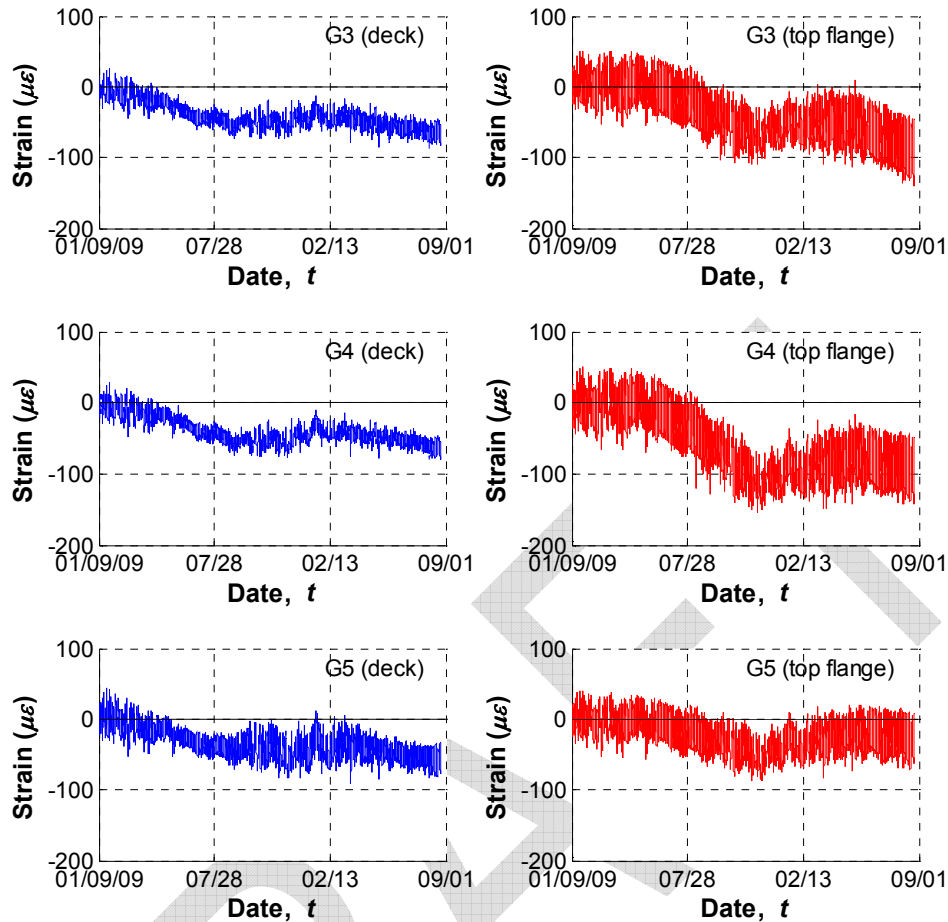


Figure 35
Strain records in deck and top flange at Girder G3, G4, and G5 locations.

Rotation of Girder Ends in Adjacent Spans

Figure 36 shows plots of the recorded rotations from the tiltmeters (TM) installed on the webs at girder ends on both sides of the monitored continuity diaphragm (Bent 24). As mentioned earlier, erroneous readings from the tiltmeters on Girders G1 and G5 led to changing two of them in June 2009 and October 2009. The tiltmeters installed on Girder G3 did not exhibit any such problems and were left untouched since their installation in January 2009. That is why their record covers the entire period since the monitoring system was installed and until the time of preparing this report as can be seen in Figure 36. Conversely, the rotation records for Girders G1 and G5 were truncated and zeroed at the time they were last adjusted.

It can be seen from the plots that rotations on both sides of the continuity diaphragm follow the same trend. This means that the girders are rotating in the same direction, which indicates

that the continuity diaphragm is doing its job of providing continuity between the girders. Had there been an expansion joint between these girders, the camber of the girders (due to creep or temperature gradient) would cause opposite signs of girder end rotation as can be seen in Figure 37. In the case of an expansion joint, the rotation angles θ_r and θ_l are of opposite signs. This can also happen if a continuity diaphragm connects both girder ends, however, there is also the possibility that one girder's movement overcomes the other resulting in similar rotation signs on both side of the diaphragm. The records of girder end rotations show both cases for the continuity diaphragm detail. Most of the time, however, the sign for rotation angles θ_r and θ_l are similar.

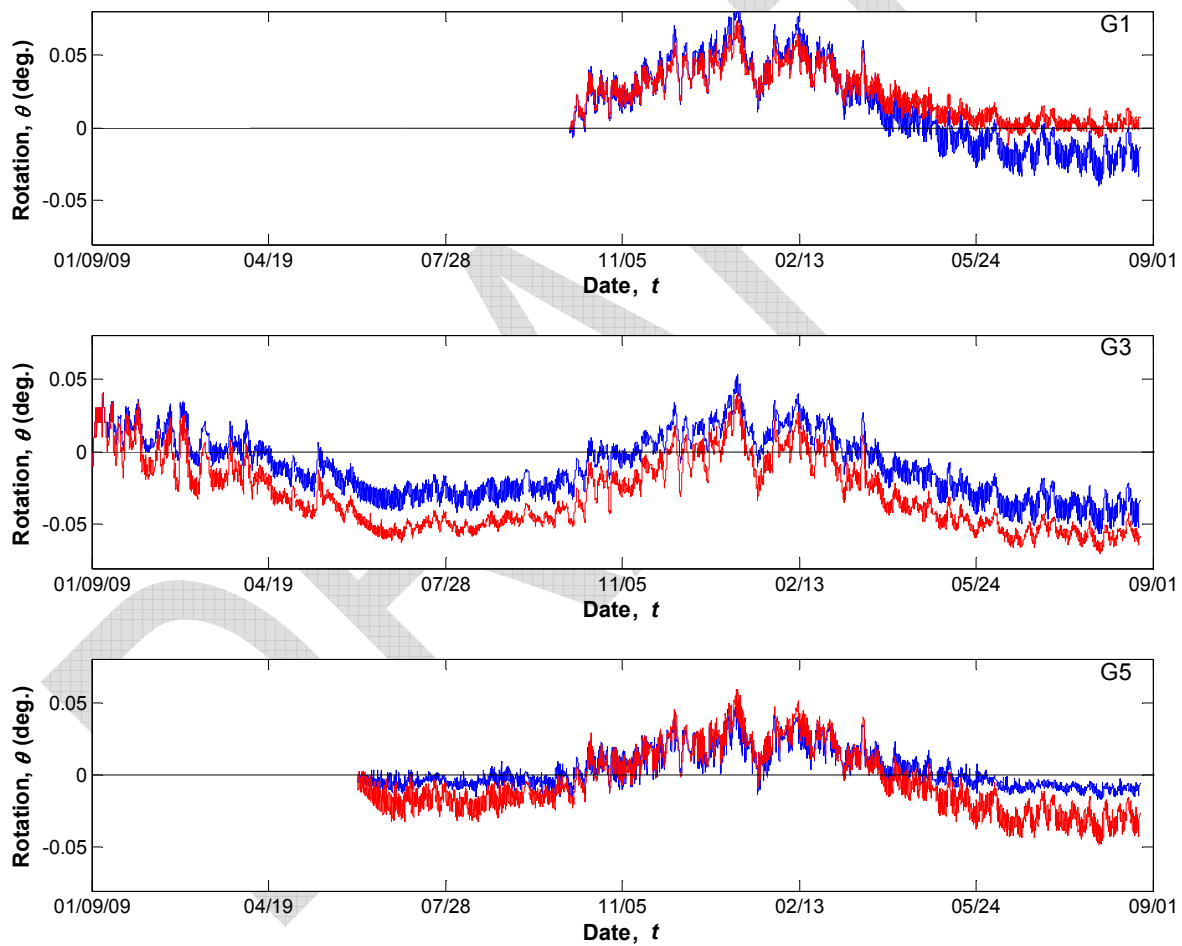


Figure 36
Rotation of girder ends (G1, G3, and G5).

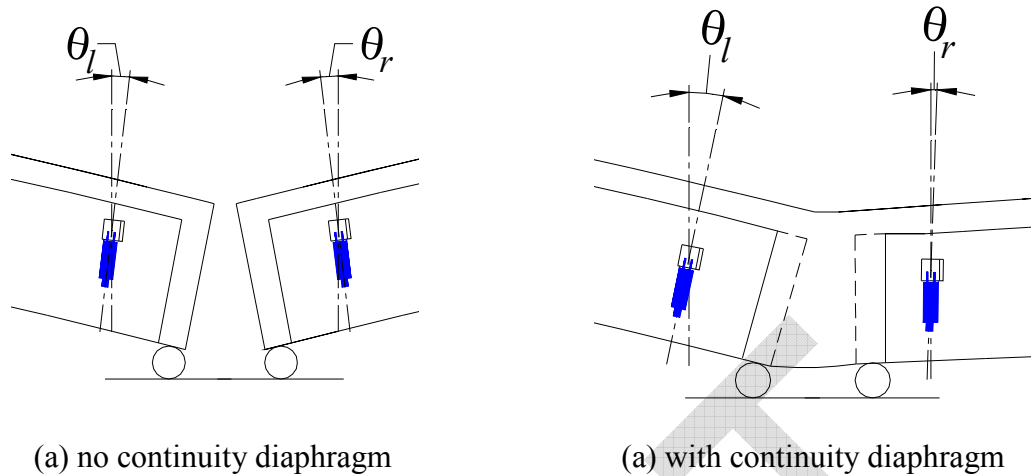
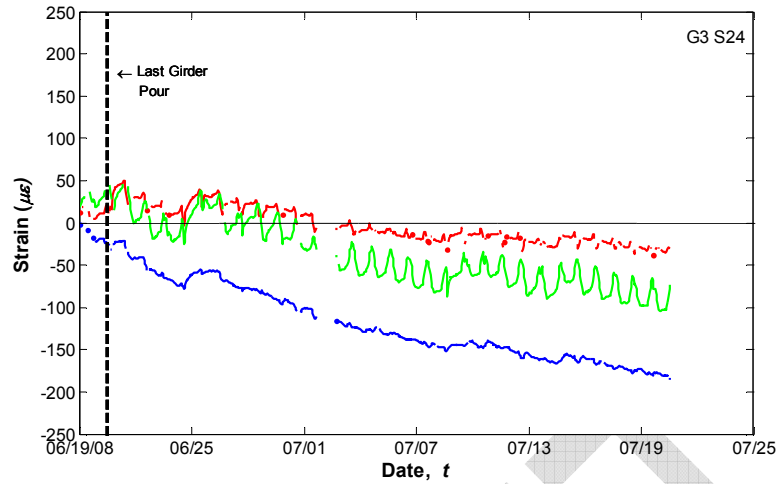


Figure 37
Schematic of girder end rotations.

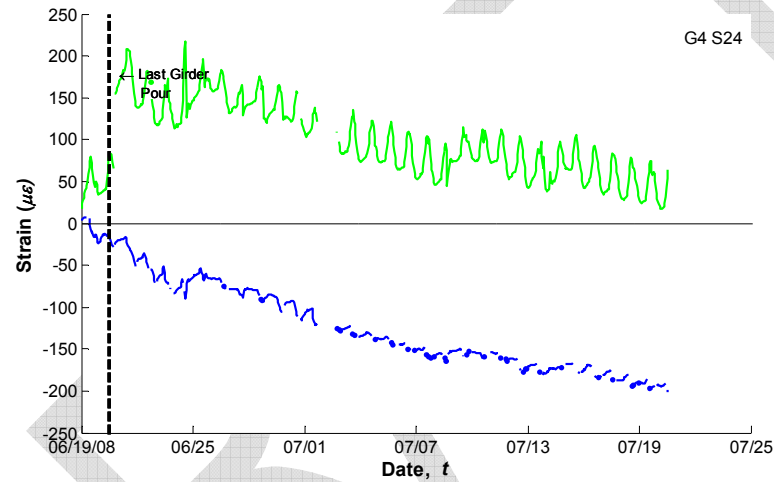
Creep of Girders During Curing Period

This section presents the strain records for three of the monitored girders while in the casting yard. The three girders are the longest span girder G3, G4, and G5. It should be noted that the presented results for Girder G5 are from the original girder that was rejected by the contractor. The results from this girder are still valid for the curing period. Three curves are shown for each girder representing the strain in the bottom flange at girder ends, and at the top and bottom flanges at midspan. Since Girder G4 was not one of the monitored girders at the continuity detail, only two curves are plotted.

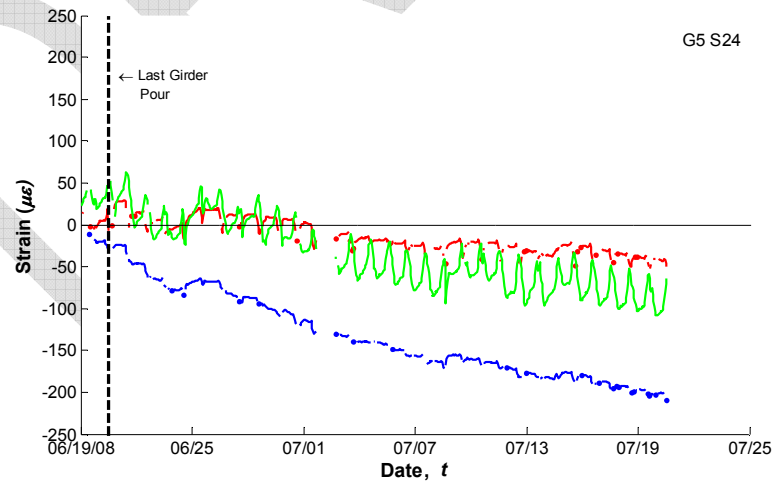
The trends for all three girders are almost identical. The strains dropped at midspan, where the full prestressing effect is acting on the section, is more than they did at the girder end, where little prestressing effect act at a few inches from the girder end. At midspan, strains in the top flanges decrease at a lesser rate than the bottom flange. The top flanges daily strain fluctuations are also larger than the other two locations; i.e. bottom flange). This is expected since the wide top flange of the bulb-T girders were exposed to direct sunlight, while the bottom flanges were always in the shade (see Figure A-11). The strain records presented in the figures during the curing period show that the strain was still dropping until the datalogger was disconnected in preparation for the girder transportation. This confirms that the girders will continue to creep after being transported to the bridge site.



(a) Girder G3



(b) Girder G4



(c) Girder G5 (rejected girder readings)

Figure 38

Early strains in Span 24 Girders G1, G3, and G5 while curing in casting yard.

Deck Cracking

The research team visited the bridge site numerous time during the period of the project. During each visit a visual inspection of deck surface cracking was conducted. Hairline cracks were observed as early as May 2009 (4 months after establishing continuity). The cracks were very limited in width (0.001 inch) and location. They mainly ran across the deck at an angle equal to the skew angle of the bents; i.e. over the continuity diaphragm. Cracking is typical in bridge decks, especially continuous ones. Nevertheless, the likelihood of the having deck cracking over continuity supports is reduced if the detail relieves the movement of the girders (such as the case of continuous decks with no continuity diaphragms), which reduces the continuity moment between spans. Figure 39 shows two of the observed cracks in the deck of the monitored segment. In Figure 39-a, which depicts the deck in the middle of the roadway, the crack is at an angle with the deck grooving. Figure 39-b shows the crack over the support in the overhang part of the deck; i.e. outside the exterior girders. Since the continuity diaphragm is not extended outside the exterior girder, the deck crack in the overhang region is free from the diaphragm's influence, and therefore propagates along the shortest distance to the edge of the deck. This explains the crack orientation in Figure 39-b, which is parallel to the deck grooving.



(a) in the middle of deck (skewed)

(a) in overhang (perpendicular)

Figure 39
Observed deck cracks over continuity detail.

Results from Parametric Study using mRESTRAINT

The results from all the cases analyzed using mRESTRAINT are given in APPENDIX . The trend of all plots are identical to that reported in NCHRP Report 519 (1). The restraint moment starts as a negative moment on the continuity diaphragm. This is mainly caused by the deck shrinkage. As the girder creep keeps increasing the restrain moment trend starts reversing direction. Girder creep causes positive restraint moment. If the effect of the girder creep is higher than the other negative-moment causing effects, the connection will eventually be subjected to positive moment. By using the procedure described in the section titled “Methodology for Establishing Age of Continuity”, minimum girder age at continuity that achieves prespecified acceptable restraint moment levels, $M_{r,a}$, were determined. Table 7 through Table 10 list the results from this study. It can be seen that the recommended 90-day age of continuity meets the demands for some of the cases presented in the tables. However, girder ages exceeding this limit were also obtained for many cases. This shows that one continuity age requirement may not be adequate for all bridge configurations. Furthermore, the these dates were determined using the creep and shrinkage models in the original RESTRAINT program. In other words, it does not account for thermal variations, especially temperature gradients. From the observations of the research team, thermal effects are probably the most important factor in developing the restraint moment. The girder ages presented in Table 7 through Table 10 would probably be lower if the thermal effects were considered.

Another observation from the results in Table 7 through Table 10 is that 3-span bridge configurations seem to require longer girder age than 2-span configurations for the same criterion. This may be attributed to the fact that middle spans in 3-span configurations are stiffer than exterior spans, thus causing higher restraint moment. Configurations with spans are only restrained on one side and hence are less stiff than the middle span of a 3-span bridge configuration of similar specification.

Table 7
Minimum girder age at continuity (in days) that meets acceptable restraint moment levels, $M_{r,a}$, (7500 days – diaphragm cracking moment)

Case	$M_{r,a}$				
	$0.0 M_{cr}$	$0.05 M_{cr}$	$0.10 M_{cr}$	$0.25 M_{cr}$	$0.50 M_{cr}$
2S-1R-1D	81	80	79	77	72
2S-0.75R-1D	94	93	91	88	84
2S-0.5R-1D	106	104	102	97	89
2S-1R-0.5D	81	80	79	77	72
2S-0.75R-0.5D	95	93	92	88	84
2S-0.5R-0.5D	107	105	103	97	89
2S-1R-0.25D	81	80	79	76	71
2S-0.75R-0.25D	95	94	92	88	84
2S-0.5R-0.25D	109	107	105	98	89
2S-1R-0.125D	81	80	79	75	70
2S-0.75R-0.125D	97	95	93	89	83
2S-0.5R-0.125D	113	111	108	100	88
2S-1R-0.05D	81	80	78	73	66
2S-0.75R-0.05D	101	99	96	89	81
2S-0.5R-0.05D	126	122	117	105	87
Average (2 spans)	97	95	93	88	81
3S-1R-1D	101	98	96	89	81
3S-1.5R-1D	102	100	98	91	82
3S-2R-1D	129	126	123	116	102
3S-1R-0.5D	101	98	96	89	81
3S-1.5R-0.5D	102	100	98	91	82
3S-2R-0.5D	130	127	124	116	102
3S-1R-0.25D	101	98	95	88	80
3S-1.5R-0.25D	103	101	98	91	81
3S-2R-0.25D	131	128	125	116	101
3S-1R-0.125D	101	98	95	87	77
3S-1.5R-0.125D	104	101	99	90	80
3S-2R-0.125D	134	131	127	117	100
3S-1R-0.05D	100	96	92	84	70
3S-1.5R-0.05D	109	105	101	89	74
3S-2R-0.05D	144	139	134	119	94
Average (3 spans)	113	110	107	98	86
Average (all)	105	102	100	93	83

Table 8
Minimum girder age at continuity (in days) that meets acceptable restraint moment levels, $M_{r,a}$ (20000 days – diaphragm cracking moment)

Case	$M_{r,a}$				
	$0.0 M_{cr}$	$0.05 M_{cr}$	$0.10 M_{cr}$	$0.25 M_{cr}$	$0.50 M_{cr}$
2S-1R-1D	83	83	82	79	75
2S-0.75R-1D	99	97	96	92	87
2S-0.5R-1D	111	109	107	102	92
2S-1R-0.5D	83	83	82	79	74
2S-0.75R-0.5D	99	98	96	92	87
2S-0.5R-0.5D	112	110	108	102	93
2S-1R-0.25D	83	82	81	79	74
2S-0.75R-0.25D	100	99	97	92	86
2S-0.5R-0.25D	115	112	110	104	93
2S-1R-0.125D	83	82	81	78	72
2S-0.75R-0.125D	102	100	98	92	86
2S-0.5R-0.125D	119	116	114	106	93
2S-1R-0.05D	83	82	80	76	68
2S-0.75R-0.05D	106	104	101	92	84
2S-0.5R-0.05D	132	128	123	111	90
Average (2 spans)	101	99	97	92	84
3S-1R-1D	107	104	102	95	85
3S-1.5R-1D	106	104	102	96	86
3S-2R-1D	135	132	129	121	108
3S-1R-0.5D	107	104	102	94	85
3S-1.5R-0.5D	107	105	102	96	86
3S-2R-0.5D	136	133	130	122	108
3S-1R-0.25D	107	104	101	93	84
3S-1.5R-0.25D	108	105	103	96	85
3S-2R-0.25D	137	134	131	122	107
3S-1R-0.125D	107	104	101	92	81
3S-1.5R-0.125D	109	106	104	95	84
3S-2R-0.125D	141	137	134	123	106
3S-1R-0.05D	106	102	98	88	74
3S-1.5R-0.05D	114	110	106	94	78
3S-2R-0.05D	151	146	141	126	101
Average (3 spans)	118	115	112	104	91
Average (all)	110	107	105	98	87

Table 9
Minimum girder age at continuity (in days) that meets acceptable restraint moment levels, $M_{r,a}$, (7500 days – PSC girder cracking moment)

Case	$M_{r,a}$				
	$0.0 M_{cr}$	$0.05 M_{cr}$	$0.10 M_{cr}$	$0.25 M_{cr}$	$0.50 M_{cr}$
2S-1R-1D	81	79	78	72	64
2S-0.75R-1D	94	91	89	84	76
2S-0.5R-1D	106	102	99	89	80
2S-1R-0.5D	81	79	77	72	63
2S-0.75R-0.5D	95	91	89	84	75
2S-0.5R-0.5D	107	103	100	89	79
2S-1R-0.25D	81	79	77	71	62
2S-0.75R-0.25D	95	92	89	84	74
2S-0.5R-0.25D	109	105	101	89	78
2S-1R-0.125D	81	79	77	70	59
2S-0.75R-0.125D	97	93	89	83	72
2S-0.5R-0.125D	113	108	103	89	76
2S-1R-0.05D	81	78	75	66	54
2S-0.75R-0.05D	101	96	90	81	65
2S-0.5R-0.05D	126	118	110	88	68
Average (2 spans)	97	93	90	81	70
3S-1R-1D	101	96	91	82	66
3S-1.5R-1D	102	98	94	84	69
3S-2R-1D	129	123	118	102	79
3S-1R-0.5D	101	96	91	81	65
3S-1.5R-0.5D	102	98	94	84	68
3S-2R-0.5D	130	124	118	102	78
3S-1R-0.25D	101	95	90	80	63
3S-1.5R-0.25D	103	99	94	83	66
3S-2R-0.25D	131	125	119	100	76
3S-1R-0.125D	101	95	89	78	59
3S-1.5R-0.125D	104	99	94	82	62
3S-2R-0.125D	134	127	120	99	73
3S-1R-0.05D	100	93	87	71	52
3S-1.5R-0.05D	109	102	95	77	54
3S-2R-0.05D	101	96	124	93	59
Average (3 spans)	113	107	101	86	66
Average (all)	105	100	95	84	68

Table 10
Minimum girder age at continuity (in days) that meets acceptable restraint moment levels, $M_{r,a}$, (20000 days – PSC girder cracking moment)

Case	$M_{r,a}$				
	$0.0 M_{cr}$	$0.05 M_{cr}$	$0.10 M_{cr}$	$0.25 M_{cr}$	$0.50 M_{cr}$
2S-1R-1D	83	82	80	75	66
2S-0.75R-1D	99	96	93	87	78
2S-0.5R-1D	111	108	104	93	83
2S-1R-0.5D	83	82	80	75	66
2S-0.75R-0.5D	99	96	93	86	78
2S-0.5R-0.5D	112	109	105	94	82
2S-1R-0.25D	83	81	80	74	64
2S-0.75R-0.25D	100	97	93	86	77
2S-0.5R-0.25D	115	110	106	94	81
2S-1R-0.125D	83	81	79	72	61
2S-0.75R-0.125D	102	98	94	86	75
2S-0.5R-0.125D	119	114	109	94	79
2S-1R-0.05D	83	80	77	68	55
2S-0.75R-0.05D	106	101	95	83	68
2S-0.5R-0.05D	132	124	116	92	71
Average (2 spans)	101	97	94	84	72
3S-1R-1D	107	102	97	86	70
3S-1.5R-1D	106	103	99	88	72
3S-2R-1D	135	129	124	108	83
3S-1R-0.5D	107	102	97	85	69
3S-1.5R-0.5D	107	103	99	87	71
3S-2R-0.5D	136	130	124	107	83
3S-1R-0.25D	107	102	96	84	67
3S-1.5R-0.25D	108	103	99	87	70
3S-2R-0.25D	137	131	125	106	80
3S-1R-0.125D	107	101	95	82	63
3S-1.5R-0.125D	109	104	99	85	66
3S-2R-0.125D	141	133	126	105	77
3S-1R-0.05D	106	98	91	75	54
3S-1.5R-0.05D	114	107	100	81	56
3S-2R-0.05D	151	140	130	100	49
Average (3 spans)	118	113	107	91	69
Average (all)	110	105	100	87	71

Results from Live Load Test

The sensor readings from the live load test are plotted in APPENDIX E. The sensor readings for each individual loading position were extracted using the approach described in the “Sample sensor reading” section (see Figure 27). As can be expected, not all sensors were highly strained by all loading positions because of their location with respect to the position of the trucks. Therefore, a minimum threshold strain is set to discard readings that are too small to be considered reliable. The results were compared to analytical results from the Global FE model. Figure 40 shows a plot of the vertical displacement contours for the P5 load case. P5 is a case that causes positive moments in Span 24 (middle span). The two trucks are positioned over Girder G1, G2, and G3. As a result, downward deformations at this location could be seen in Figure 40. At the same time, upward movement of girders in adjacent spans (23 and 25) take place.

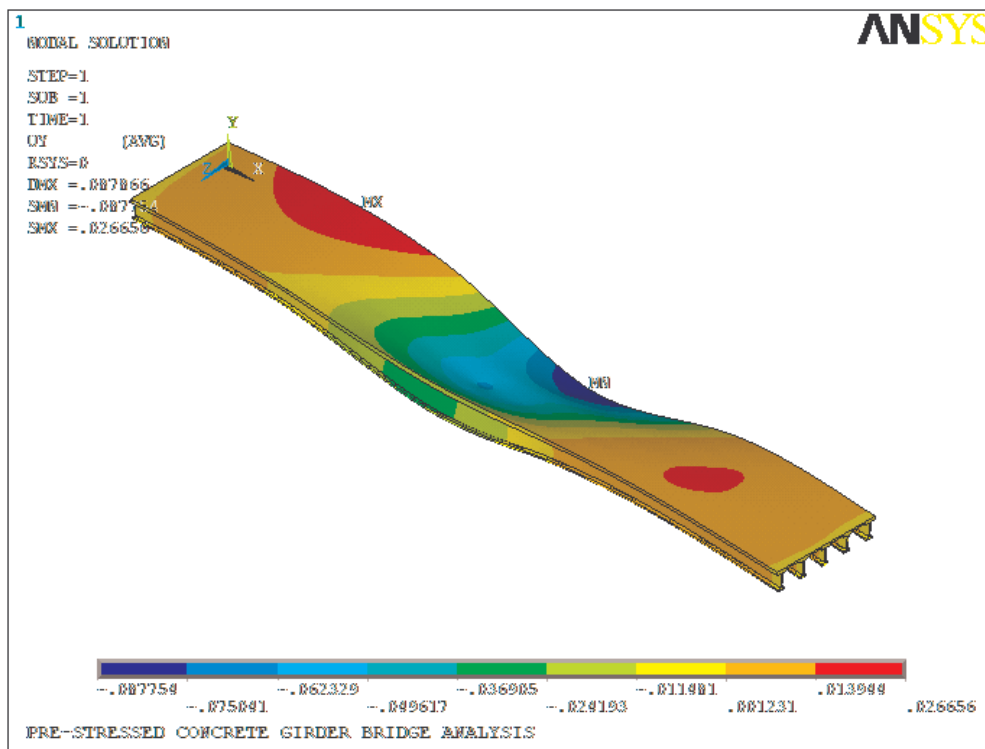


Figure 40
Contours of vertical displacement (Case P5).

Table XXX lists the strain results for the hairpin bars and the midspan top and bottom strains. It can be seen that there is good correlation between the analytical results and field data.

Since the FE model assumes continuity, the results imply that the new diaphragm performs as a continuity diaphragm that is capable of transferring forces from one span to the other.

One interesting observation is that the hairpin strain records confirm that forces were transferred from Span 25 (loaded span) to Span 23 (monitored span) for load positions P3 and P6. These two cases cause positive moments on the monitored continuity detail. Figure 41 shows the magnitude of the strains, which are larger for Girder G3 than G1. A similar observation is related to the recorded negative strains for load positions P2 and P5. Both are load cases that target positive moment in the middle of Span 24. Therefore, trucks are positioned over Span 24. They trucks would however, apply negative moments on the continuity diaphragm if it performs as intended. In both load positions (P2 and P5), the hairpin bars experienced negative strains that are, as expected, higher than the positive strains discussed earlier. Like the P3 and P6 load cases, the sensors are in one span and the loads act on another for these two cases. Hence, the ability of the new detail to transfer forces between spans is confirmed. It should be noted that Girder G5 was not instrumented on the hairpin bars and therefore a plot was provided.

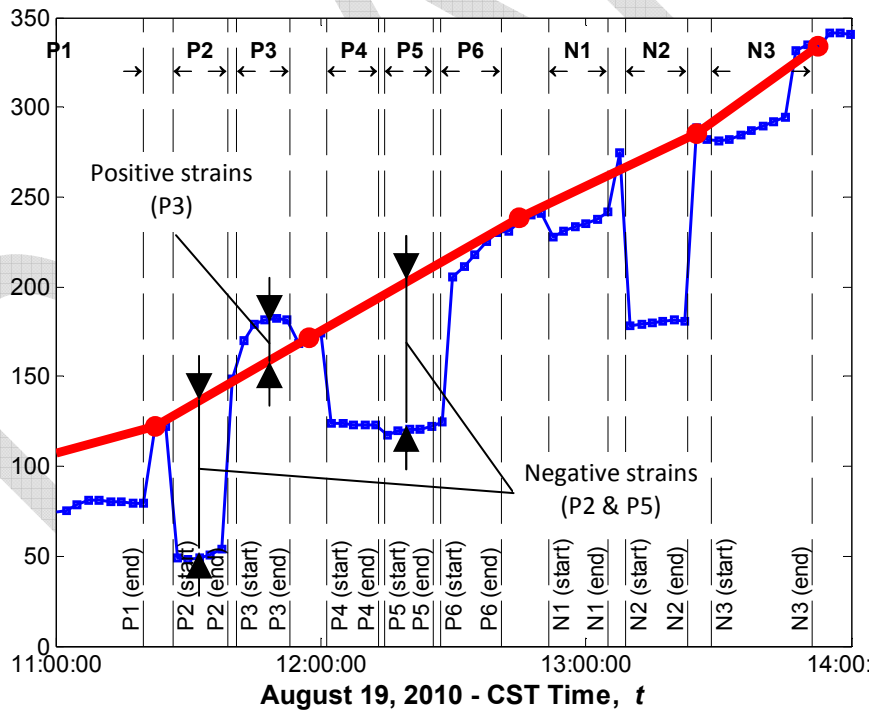
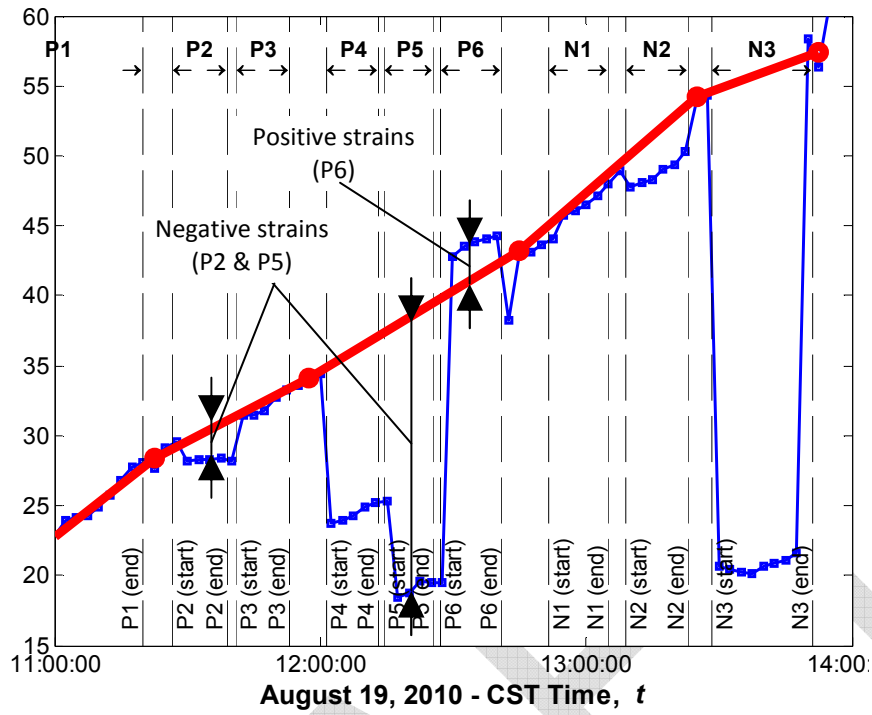


Figure 41
Strains in hairpin bars showing positive values for faraway load cases

Feedback from Contractors

During the installation process, discussions with the precaster and the contractor's site engineers about the continuity detail ensued. The precaster's point of view can be summarized in the following points:

- Hairpin bars require special end of girder forms, which can be made of multiple wooden or steel pieces. Extra attention is required to prevent leaking between the pieces. Wooden forms are not usable and therefore many of them will have to be manufactured for any given project. Steel forms are costlier and if not many girders are to cast with the same detail, it adds to the cost.
- The labor involved in adding hairpin bars is minimal. A maximum estimate to insert the bars and tie them is 30 minutes per girder.

As expected, the precaster would rather not have to install hairpin bars because of the additional effort, albeit minimal. The casting yard engineer indicated that inserting hairpin bars is not any worse than dealing with skews. They would do it if they have to, but would rather not.

Stronger comments about the detail came from the contractor. The project engineer for Bridge #2 indicated the following:

- Hairpin bars add difficulties to the girder installation process. First, particular attention needs to be paid to the alignment of the bars in the girder so there isn't a conflict in the field with the dowels or adjacent girder loops. Also, threading the diaphragm steel through these loops is difficult, as this is done after the girders are erected, which makes the workspace congested.
- The additional cost for this type of continuity diaphragm is approximately 15-20% more than conventional diaphragms, due mainly to the extra time it takes to construct them.
- The contractor would rather build conventional LA-DOTD diaphragms than the NCHRP 519 positive moment continuity detail.

SUMMARY AND CONCLUSIONS

Summary

A detailed study on the performance of the NCHRP 519 (I) continuity detail has been conducted. The study involved the installation of a structural health monitoring system on a newly constructed bridge from the John James Audubon Project. Bridge #2 was chosen for the study because it is skewed and uses Bulb-T (BT-72) girders. The 96-channel monitoring system included embedded and surface-mounted sensors that measure strains, rotations, and gap openings. Data from for almost a 24-month period has been collected including some data from the period when the girders were curing in the casting yard. The data was processed and analyzed to better understand the performance of the new detail.

Analytical models were also developed to study the restraint moment acting on this type of detail. First, the program that resulted from the NCHRP 519 study is modified to expand its applicability to bridges like the monitored bridge segment; i.e. unsymmetric span lengths and different girder configurations. The modified program (mRESTRAINT) was used to conduct a parametric study to determine minimum girder age requirements that meet prespecified design criteria. Three finite element models were also developed to study the global behavior as well and the local stress distribution in bridges employing the new detail.

Finally, a live load test was conducted on the monitored bridge segment. Static and dynamic load tests were carried out. The results from the live load tests were studied to study the performance of the new detail under live loads.

Conclusions

The conclusions from this study can be summarized in the following:

1. Positive moments develop in bridges employing the new continuity detail. They are caused by long-term effects such as girder creep and thermal variations.
2. The continuity detail has the ability to transfer forces from one girder end to the

adjacent girder end across the continuity diaphragm.

3. Positive restraint moment can cause cracking in the diaphragm and/or girder ends. Both types of cracking affect the performance of the diaphragm and hence the bridge. More importantly, girder cracking may have adverse effects on the durability and on the shear capacity of the girders. Therefore, special care should be given to the level of positive restraint moment during design.
4. Seasonal and daily temperature variations can cause large restraint moments in the bridge; especially temperature gradients. The level of restraint moment due to the combined seasonal and daily temperature is probably the most important factor in the design of this detail, since the designer has little influence on the temperatures at the bridge site. The other positive-moment causing factor; i.e. girder creep caused by prestressing forces, can be greatly reduced by not introducing continuity until a large portion of the creep takes place prior to pouring the diaphragm.
5. It appears based on the parametric study that the girder age at which continuity can be introduced to achieve acceptable positive moment levels varies based on bridge configuration. Therefore, the recommended 90-day age from NCHRP 519 will need to be evaluated for each design project.
6. The live load test revealed that the continuity detail transferred negative and positive moments across the diaphragm. The strains from the live load test were much lower compared to other long-term effects. Even if the actual design load were to be applied (approximately twice the live load test), the strains would still be small. Therefore, the live load case should be considered in the design; however, it is not the most demanding action on the detail.
7. The construction cost of the detail is not substantial for the precaster although they would rather build girders without the detail. The contractor's critique of the new detail was stronger than the precaster. The contractor is of the opinion that the continuity diaphragm, especially for skewed bridge configurations, is cumbersome and adds to the construction time. Simpler details would expedite the construction of slab-on-girder bridges.

RECOMMENDATIONS

The research team recommends that the employment of this new detail be allowed only after thorough investigation of its benefits; both structurally and economically, on a per project case. When employed, the design should account for factors affecting the development of the positive moment acting on the continuity detail including creep due to prestressing forces, differential shrinkage, and seasonal as well as daily thermal variations. Special consideration shall be given to the effects of temperature gradient in the design of this detail.

Simpler details expedite the construction of this type of bridge and need to be one of the studied alternatives for new projects. *Partial Integration* is one such detail which eliminates the expansion joint without developing large continuity moment over the supports. This can be achieved by pouring continuous decks over simply supported girders.

The modified RESTRAINT program (mRESTRAINT) does not consider temperature gradient effects, which is one of the most important causes of positive restraint moment. It is therefore recommended that thermal effects be studied using other structural analysis tools. Future modifications of mRESTRAINT to include the effect of thermal gradients are possible and recommended to keep the design of the new detail in one tool.

The John James Audubon Project involves many bridges that employ the new detail. This is an excellent long-term testbed for the performance of the new detail. It is recommended that visual inspections of the hundreds of employed joints, similar to the one investigated in this report, be conducted. This opportunity can provide invaluable long-term performance information.

ACRONYMS, ABBREVIATIONS, & SYMBOLS

AASHTO	The American Association of State Highway and Transportation Officials
A_g	Area of girder
PVC	Poly vinyl chloride
DOT	Department of transportation
A_c	Gross area of concrete
A_{tr}	Concrete deck slab area with transformed reinforcement area
A_s	Area of steel
C	Calibration factor for the sensor
C	Age of girder at the time of continuity
D	Ratio of diaphragm stiffness
Dr_L, Dr_M, Dr_H :	Relative densities corresponding to low, medium and high compressibility conditions.
d_b	Diameter of prestress strand
E_{qt}	Equation of time
E	Modulus of elasticity
$E_{c \text{ deck}}$	Modulus of elasticity of deck concrete
e	Eccentricity
f_1	Natural frequency of the datum
f_2	Natural frequency of the measured readings
f_r	Modulus of rupture
f_{pe}	Effective prestress
f_{psi}	Stress in the strand at the service limit state
f_{pul}	Stress in the strand at the strength limit state
g	Acceleration due to gravity
k	Gauge constant
I_{dia}	Diaphragm Moment of Inertia
I_g	Girder Moment of Inertia
I_0	Extraterrestrial solar radiation
$Long_{sm}$	Longitude of standard meridian
$Long_{local}$	Longitude of local time zone
L_i	Span length for Span i

LADOTD:	Louisiana department of transportation and development
LRFD	Load and Resistance Factor Design
LSD	Limit State Design
LTRC	Louisiana transportation research center
l_t	Transfer length
l_{dsh}	Total length of extended strand
M_{cr}	Cracking moment
M_r	Restraint Moment
$M_{r,a}$	Allowable Restraint Moment
n	Modular ratio
NaN	Not a number
NCHRP	National Cooperative Highway Research Program
NOAA	National Oceanic and Atmospheric Administration
PCBT	Precast concrete bulb tee girders
P_e	Effective prestressing force
ppm	Parts per million
t	Time in days or hours
R	Ratio of span lengths
R_0	Initial sensor reading in digit
R_1	Current sensor reading in digit
T_0	Initial temperature
T_1	Current temperature
T_{solar}	Solar time
VDOT	Virginia department of transportation
w	Hour angle
x_i	Monitored data
\bar{x}	Mean
y_t	Distance from neutral axis to the top of girder
$\mu\varepsilon$	Microstrain
ε_{sh}	Unrestrained shrinkage strain
σ	Standard deviation
ρ	Density
θ	Slope

DRAFT

REFERENCES

1. Miller, R. A., Castrodale, R., Mirmiran, A., and Hastak, M. "Connection of Simple-Span Precast Concrete Girders for Continuity." NCHRP Report 519, Transportation Research Board, Washington, D.C., 2004.
2. Okeil, A. M.; and El-Safty, A. K. "Partial Continuity in Bridge Girders with Jointless Decks," Practice Periodical on Structural Design and Construction, ASCE, Vol. 10, No. 4, 2005, pp. 229-238.
3. Loveall, C. L. "Jointless Bridge Decks," Civil Engineering, ASCE, Vol. 55, No. 11, 1985, pp. 64-67.
4. Wasserman, E. P. "Jointless Bridge Decks," AISC Engineering Journal, AISC, Vol. 24, No. 3, 1987, pp. 93-100.
5. Russell, H. G.; and Gerken, L. J. "Jointless Bridges – the Knowns and the Unknowns," Concrete International, ACI, Vol. 16, No. 4, 1994, pp. 44-48.
6. Burke, M. P., Jr. "Integral Bridges: Attributes and Limitations," ACI National Concrete Engineering Conference, Chicago, IL, 1992.
7. Burke, M. P., Jr. "Semi Integral Bridges: Movements and Forces," Transportation Research Record, National Research Council, Vol. 1460 1994, pp. 1-7.
8. Burke, M. P., Jr. "Reducing Bridge Damage Caused By Pavement Forces," Concrete International, ACI, Vol. 26, No. 2, 2004, pp. 83-89.
9. Alampalli, S.; and Yannotti, A. P. "In-Service Performance of Integral Bridges and Jointless Decks," Transportation Research Record, National Research Council, Vol. 1624 1998, pp. 1-7.
10. Thippeswamy, H. K.; GangaRao, H. V. S.; and Franco, J. M. "Performance Evaluation of Jointless Bridges," Journal of Bridge Engineering, ASCE, Vol. 7, No. 5, 2002, pp. 276-289.
11. Demartini, C. J.; and Haywood, R. J. "Repair of the Southern Approach to the Story Bridge by Elimination of the Contraction Joints," Autostrads Conference, Brisbane, Australia, 1991, pp. 357-370.
12. Pierce, P. "Jointless Redecking," Civil Engineering, ASCE, Vol. 61, No. 9, 1991, pp. 60-64.
13. Caner, A.; and Zia, P. "Behavior and Design of Link Slabs for Jointless Bridge Decks," PCI Journal, PCI, Vol. 43, No. 3, 1998, pp. 68-80.
14. Caner, A.; Dogan, E.; and Zia, P. "Seismic Performance of Multisimple-Span Bridges Retrofitted with Link Slabs," Journal of Bridge Engineering, ASCE, Vol. 7, No. 2, 2002, pp. 85-93.
15. Wing, K. M.; and Kowalsky, M. J. "Behavior, Analysis, and Design of an Instrumented Link Slab Bridge," Journal of Bridge Engineering, ASCE, Vol. 10, No. 3, 2005, pp. 331-344.

16. Siros, K. A.; and Spyarakos, C. C. "Creep Analysis of Hybrid Integral Bridges," Transportation Research Record, National Research Council, Vol. 1476 1995, pp. 147-154.
17. Gastal, F.; and Zia, P. "Analysis of Bridge Beams with Jointless Decks," IABSE Symposium, Lisbon, Portugal, 1989, pp. 555-560.
18. Richardson, D. R. "Simplified Design Procedures for the Removal of Expansion Joints from Bridges Using Partial Debonded Continuous Decks." M.Sc., North Carolina State University, 1989.
19. Thippeswamy, H. K.; and GangaRao, H. V. S. "Analysis of In-Service Jointless Bridges," Transportation Research Record, National Research Council, Vol. 1476 1995, pp. 162-170.
20. Zia, P., Caner, A., and El-Safty, A. "Jointless Bridge Decks." Research Report No. FHWA/NC/95-006, Center for Transportation Engineering Studies, 1995.
21. Oesterle, R. G., Glikin, J. D., and Larson, S. C. "Design of Precast Prestressed Bridge Girders Made Continuous." NCHRP Report No. 322, Transportation Research Board, Washington, D.C., 1989.
22. Newhouse, C. D. "Design and Behavior of Precast, Prestressed Girders Made Continuous – An Analytical and Experimental Study." Ph.D. Dissertation, Department of Civil and Environmental Engineering, Virginia Polytechnic Institute and State University, 2005.
23. Saber, A., Toups, J., Guice, L., and Tayebi, A. "Continuity Diaphragm for Skewed Continuous Span Precast Prestressed Concrete Girder Bridges." 01-1ST, Louisiana Transportation Research Center, Baton Rouge, LA, 2004.
24. Saber, A. "Field Verification for the Effectiveness of Continuity Diaphragms for Skewed Continuous P/C P/S Concrete Girder Bridges." 06-3ST, Louisiana Transportation Research Center, Baton Rouge, LA, 2009.
25. Cai, S. C. S., and Avent, R. R. "Assessing the Needs for Intermediate Diaphragms in Prestressed Concrete Bridges." 03-3ST, Louisiana Transportation Research Center, Baton Rouge, LA, 2008.
26. Mattock, A. H. "Precast-Prestressed Concrete Bridges, 5. Creep and Shrinkage Studies," , 1961.
27. Freyermuth, C. L. "Design of continuous highway bridges with precast, prestressed concrete girders," 1969
28. Peterman, R. J. "Restraint moments in bridges with full-span prestressed concrete form panels," 1998
29. McDonagh, M. D. "Resolving restraint moments: Designing for continuity in precast prestressed concrete girder bridges," 2003
30. ASTM Standard C 39 . "Standard Test Method for Compressive Strength of Cylindrical Concrete Specimens," ASTM International, West Conshohocken, PA, 2005.
31. ASTM Standard C 469 . "Standard Test Method for Static Modulus of Elasticity and

- Poisson's Ratio of Concrete in Compression," ASTM International, West Conshohocken, PA, 2002.
32. ASTM Standard C 78 . "Standard Test Method for Flexural Strength of Concrete (Using Simple Beam with Third-Point Loading)," ASTM International, West Conshohocken, PA, 2002.
 33. ASTM Standard C 496 . "Standard Test Method for Splitting Tensile Strength of Cylindrical Concrete Specimens," ASTM International, West Conshohocken, PA, 2004.
 34. Mirmiran, A. "Nonlinear continuity analysis of precast, prestressed concrete girders with cast-in-place decks and diaphragms," 2001
 35. Chebole, V. "Continuity Moment Assessment in Prestressed Concrete Bridge Girders." M.S. Thesis, Louisiana State University, Baton Rouge, Louisiana, USA, 2010.
 36. ANSYS. "Theory Reference," ANSYS, Inc., Canonsburg, PA, 2008.
 37. AASHTO. LRFD Bridge Design Specifications. American Association of State Highway and Transportation Officials, Washington, D.C., 2008.

APPENDIX A

Picture Documentation and More Details of Installed Sensors

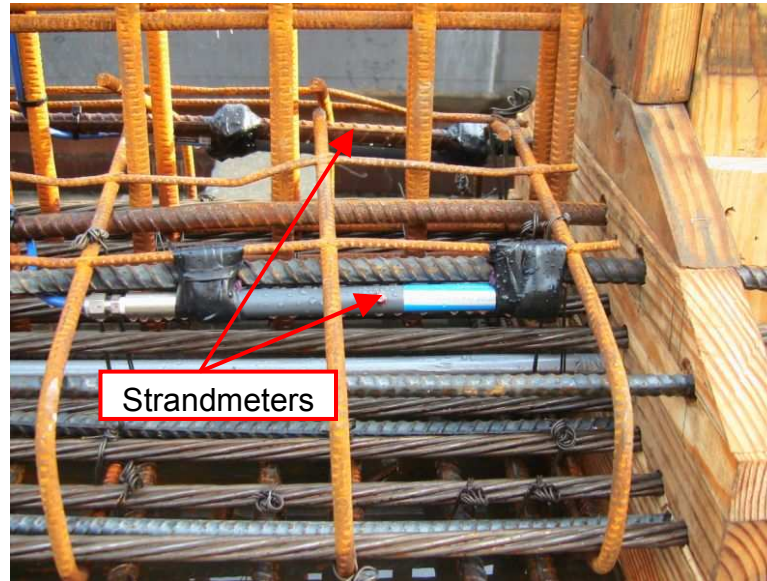


Figure A-1
Strandmeters installed on hairpin bars at girder ends.



Figure A-2
Sisterbar installed next to a prestressing strand at midspan.



Figure A-3
Strandmeters installed on reinforcing bars in deck over continuity diaphragm.



Figure A-4
Sisterbars installed next to reinforcing bars in deck over continuity diaphragm.



Figure A-5
Surface-mounted sensors (vibrating wire gages and tiltmeters) at girder ends.



Figure A-6
Gap meter installed on brackets connected to girder ends at continuity diaphragm.



Figure A-7
Protection of wiring for embedded sensors prior to concrete casting.



Figure A-8
Surge protectors installed on one of every two embedded sensors at the same location.



Figure A-9
Solar panel powering the monitoring system.



Figure A-10
Campbell Scientific datalogger.



Figure A-11
Datalogger location while monitoring of curing girders in casting yard.



Figure A-12
Datalogger location in the complete system at bridge site. (Bent 24)



Figure A-13
Curing of bridge deck.

DRAFT

**Table A-1
Installed sensor details**

MUX 1					
Logger Ch.	Mux Chan	SN	Type	Cal	Location
1	1	7885	ES	3.07	G1 Span 24 (Support - Bottom)
2	2	7886	ES	3.06625	G1 Span 24 (Support - Bottom)
3	3	10244	ES	3.04125	G1 Span 23 (Support - Bottom)
4	4	10245	ES	3.04375	G1 Span 23 (Support - Bottom)
5	5	22073	EC	0.347	G1 Span 24 (Support - Top)
6	6	20554	ES	3.07	G2 Span 24 (Support - Top)
7	7	15373	TM	0.002488	G1 Main Span 24 (+ Towards Mid Span)
8	8	15963	TM	0.002452	G1 Main Span 23 (+ Towards Mid Span)
9	9	21547	DM2	0.0004124	G1 Connection
10 through 16	10 - 16	-	-	-	-
MUX 2					
Logger Ch.	Mux Chan	SN	Type	Cal	Location
17	1	-	VW	0.96	G1 Span 24 (Support -Top)
18	2	-	VW	0.96	G1 Span 24 (Support - Middle)
19	3	-	VW	0.96	G1 Span 24 (Support - Bottom)
20	4	-	VW	0.96	G1 Span 23 (Support -Top)
21	5	-	VW	0.96	G1 Span 23 (Support -Middle)
22	6	-	VW	0.96	G1 Span 23 (Support -Bottom)
23 through 32	7 - 16	-	-	-	-
MUX 3					
Logger Ch.	Mux Chan	SN	Type	Cal	Location
33	1	-	VW	0.96	G5 Span 24 (Support -Top)
34	2	-	VW	0.96	G5 Span 24 (Support - Middle)
35	3	-	VW	0.96	G5 Span 24 (Support - Bottom)
36	4	-	VW	0.96	G5 Span 23 (Support - Top)
37	5	-	VW	0.96	G5 Span 23 (Support - Middle)
38	6	-	VW	0.96	G5 Span 23 (Support - Bottom)
39	7	-	VW	0.96	G3 Span 24 (Support - Top)
40	8	-	VW	0.96	G3 Span 24 (Support - Middle)
41	9	-	VW	0.96	G3 Span 24 (Support - Bottom)
42	10	-	VW	0.96	G3 Span 23 (Support - Top)
43	11	-	VW	0.96	G3 Span 23 (Support - Middle)
44	12	-	VW	0.96	G3 Span 23 (Support - Bottom)
45	13	10240	ES	3.0525	G5 Span 24 (Support - Bottom)
46	14	10241	ES	3.05	G5 Span 24 (Support - Bottom)
47	15	10432	EC	0.346	G5 Span 24 (Support - Top)
48	16	20552	ES	3.06375	G4 Span 24 (Support - Top)

Table A-1 (continued)
Installed sensor details

MUX 4					
Logger Ch.	Mux Chan	SN	Type	Cal	Location
49	1	7882	ES	3.06625	G3 Span 24 (Support - Bottom)
50	2	10242	ES	3.045	G3 Span 23 (Support - Bottom)
51	3	10243	ES	3.05	G3 Span 23 (Support - Bottom)
52	4	10252	ES	3.05	G3 Span 24 (Support - Bottom)
53	5	22072	EC	0.355	G3 Span 24 (Support - Top)
54	6	15966	TM	0.002518	G5 Main Span 24 (+ Towards Bent 24)
55	7	15964	TM	0.002468	G3 Main Span 24 (+ Towards Main Span)
56	8	15965	TM	0.002449	G3 Main Span 23 (+ Towards Mid Span)
57	9	15967	TM	0.002465	G5 Main Span 23 (+ Towards Mid Span)
58	10	21549	DM2	0.0004115	G3 Connection
59	11	21548	DM2	0.0004107	G5 Connection
60 through 64	12 - 16	-	-	-	-

MUX 5					
Logger Ch.	Mux Chan	SN	Type	Cal	Location
65	1	-	VW	0.96	G5 Span 24 (Midspan - Top)
66	2	-	VW	0.96	G5 Span 24 (Midspan - Middle)
67	3	-	VW	0.96	G5 Span 24 (Midspan - Bottom)
68	4	10430	EC	0.345	G5 Span 24 (Midspan - Top)
69	5	10431	EC	0.343	G5 Span 24 (Midspan- Bottom)
70	6	10435	EC	0.354	G5 Span 24 (Midspan - Deck)
71	7	-	VW	0.96	G1 or G2 Span 24 (Midspan - Bottom)
72	8	-	VW	0.96	G1 or G2 Span 24 (Midspan - Bottom)
73 through 80	9 - 16	-	-	-	-

MUX 6					
Logger Ch.	Mux Chan	SN	Type	Cal	Location
81	1	-	VW	0.96	G3 Span 24 (Midspan -Top)
82	2	-	VW	0.96	G3 Span 24 (Midspan - Middle)
83	3	-	VW	0.96	G3 Span 24 (Midspan - Bottom)
84	4	-	VW	0.96	G4 Span 24 (Midspan -Top)
85	5	-	VW	0.96	G4 Span 24 (Midspan -Middle)
86	6	-	VW	0.96	G4 Span 24 (Midspan -Bottom)
87	7	7883	ES	3.0475	G3 Span 24 (Midspan -Top)
88	8	7884	ES	3.075	G3 Span 24 (Midspan -Bottom)
89	9	10250	ES	3.05625	G4 Span 24 (Midspan - Bottom)
90	10	10251	ES	3.02625	G4 Span 24 (Midspan - Top)
91	11	10426	EC	0.343	G3 Span 24 (Midspan - Top)
92	12	10427	EC	0.351	G3 Span 24 (Midspan - Bottom)
93	13	10428	EC	0.349	G4 Span 24 (Midspan -Top)
94	14	10429	EC	0.351	G4 Span 24 (Midspan -Bottom)
95	15	10433	EC	0.351	G3 Span 24 (Midspan - Deck)
96	16	10434	EC	0.344	G4 Span 24 (Midspan - Deck)

INSTRUMENTATION PLAN
(Embedded - Deck)

	Support Line	#2	Joint	#3		Mid-span	
		↓	↓	↓		↓	
Embedded Strain gauge (sisterbars)	EC	= 0	+ 3	+ 0		+ 3	= 6
Embedded Strain gauge (strandmeter)	ES	= 0	+ 2	+ 0		+ 0	= 2
Total		= 0	+ 5	+ 0		+ 3	= 8

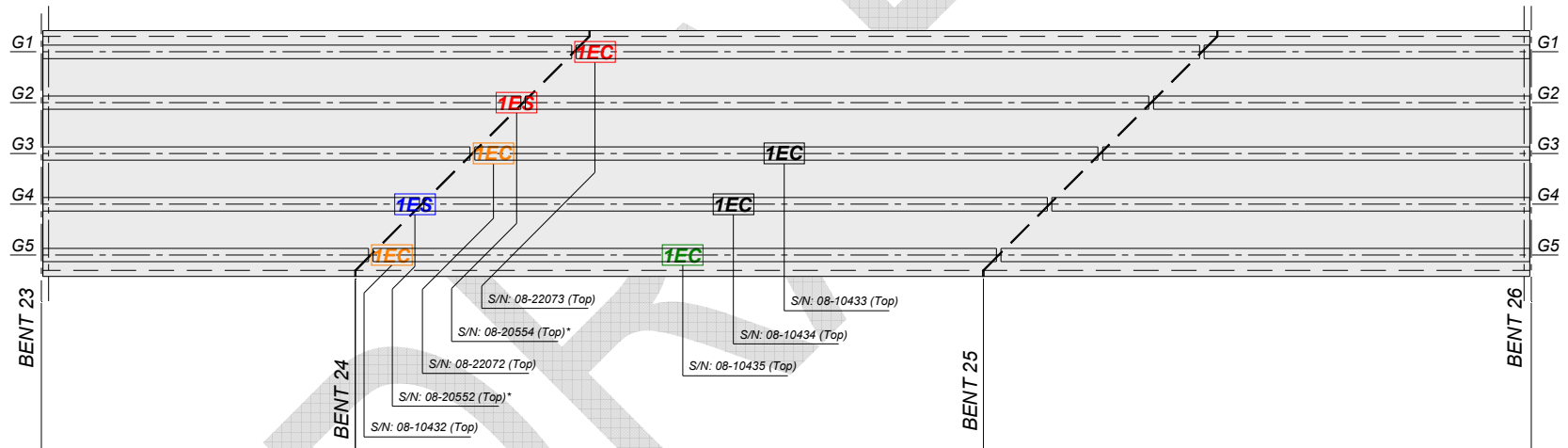
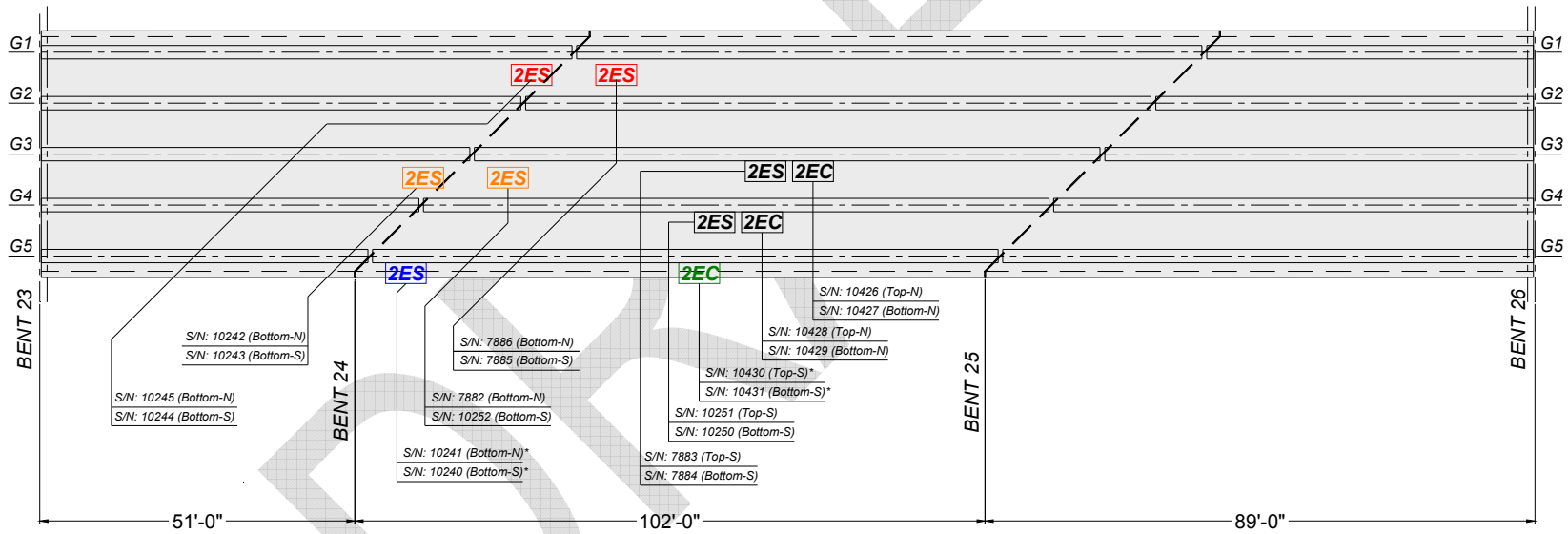


Figure A-14
Distribution of sensors on system multiplexers.

INSTRUMENTATION PLAN (Embedded - Girders)

	Support Line	#2	Joint	#3		Mid-span
	↓	↓	↓	↓		↓
Embedded Strain gauge (sisterbars)	EC	= 0	+ 0	+ 0		+ 6 = 6
Embedded Strain gauge (strandmeter)	ES	= 4	+ 0	+ 6		+ 4 = 14
Total		= 4	+ 0	+ 6		+ 10 = 20



* replacement girder - sensor S/N's are different than original installation

* following sensors were lost in rejected girder:

10246 (ES)	10247 (ES)	10425 (EC)
10248 (ES)	10424 (EC)	10249 (ES)

Figure A-15
Distribution of sensors on system multiplexers.

INSTRUMENTATION PLAN
(External - Diaphragm)

Support Line #2 Joint #3 Mid-span

Displacement Meters $DM = 0 + 3 + 0$
Total = 0 + 3 + 0

+ 0 = 3
+ 0 = 3

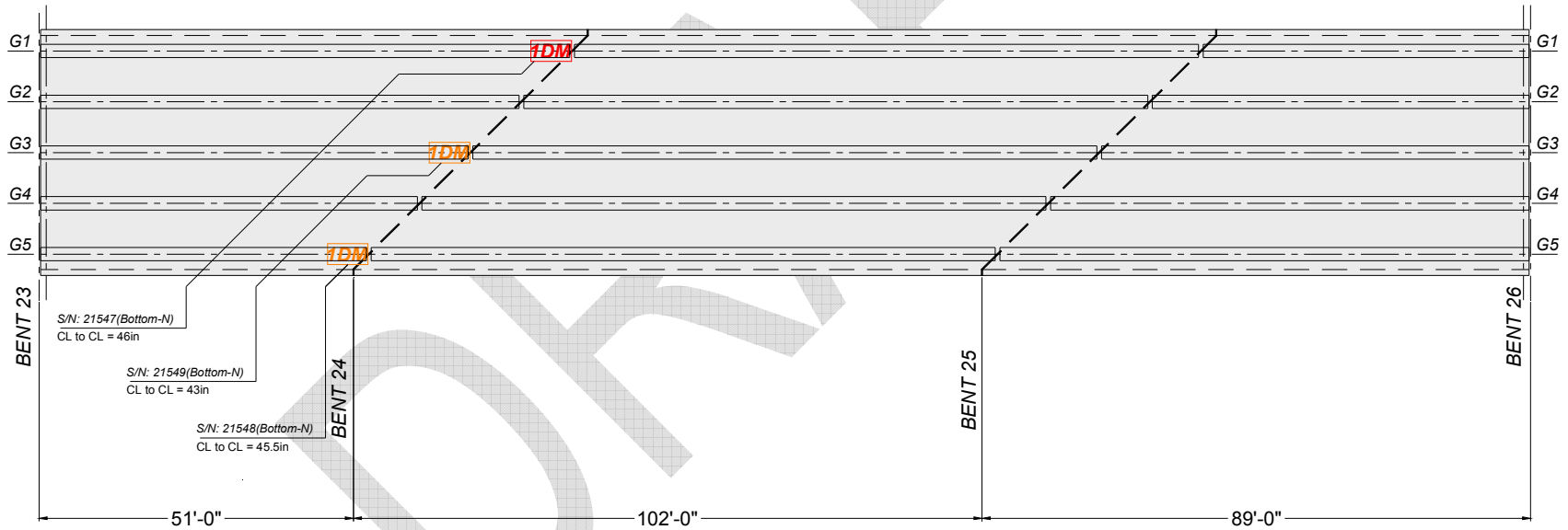


Figure A-16
Distribution of sensors on system multiplexers.

INSTRUMENTATION PLAN (External - Girders)

Support Line #2 Joint #3 Joint #3

↓ ↓ ↓

Mid-span

↓

Vibrating Wire Strain gauge **VW** = 9 + 0 + 9

Vibrating Wire Tiltmeter **TM** = 3 + 0 + 3

Total = 12 + 0 + 12

+ 11 = 29

+ 0 = 6

+ 11 = 35

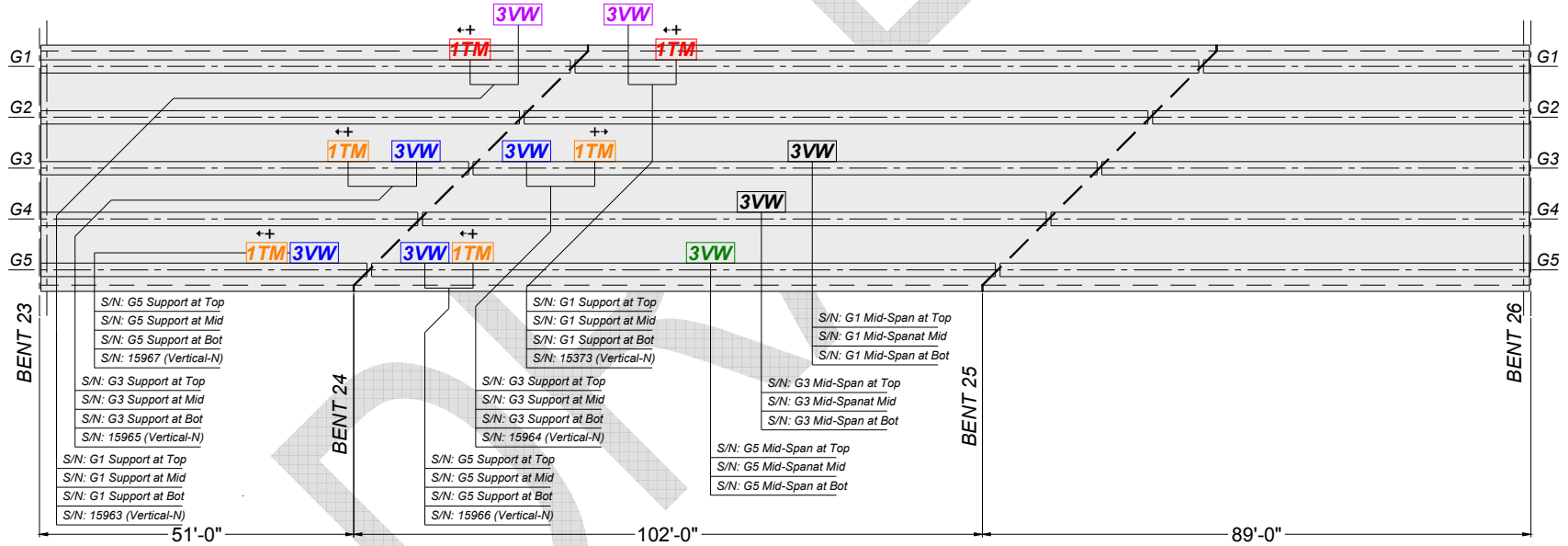


Figure A-17
Distribution of sensors on system multiplexers.

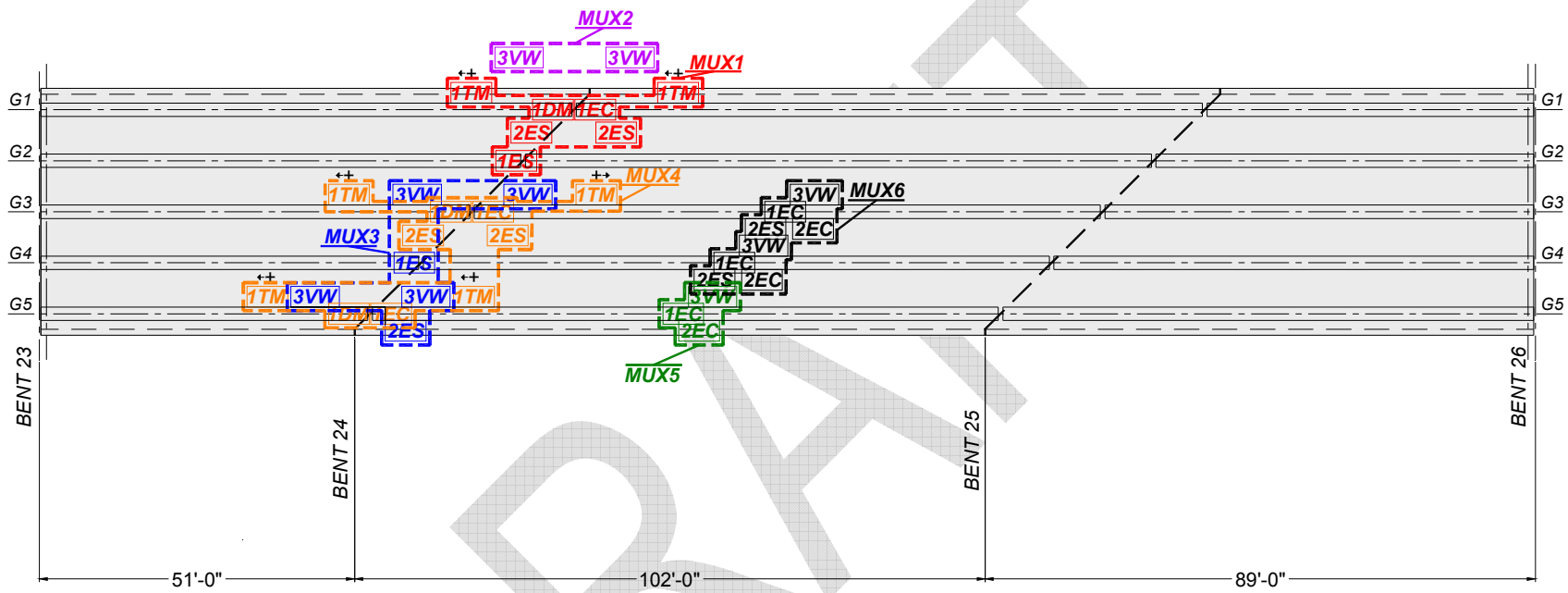


Figure A-18
Distribution of sensors on system multiplexers (MUX1 through MUX6).

APPENDIX B

Major Modifications to RESTRAINT Program

This appendix presents the major modifications by the research team of the RESTRAINT program. Screen captures of the input forms (windows) of the original, and the modified, RESTRAINT are presented.

N/A

Original RESTRAINT

The screenshot shows a dialog box titled "SectionDimensions" with the following elements:

- Radio buttons for AASHTO Type I, AASHTO Type II, AASHTO Type III, AASHTO Type IV, AASHTO Type V, AASHTO Type VI, AASHTO BT-72, and **CUSTOM** (selected).
- Input fields for dimensions B1, B2, B3, B4, B5, B6, D1, D2, D3, D4, D5, D6, D7, and D8.
- A diagram of an I-girder cross-section with dimension lines labeled B1, B2, B3, B4, B5, B6, D1, D2, D3, D4, D5, D6, D7, and D8.
- "Back" and "Next" buttons at the bottom.

Modified mRESTRAINT

Figure B-1

Introducing custom cross-sectional dimensions of I-girders..

inputvalues5

Input Data for 5 span continuous girder

Select Girder Type (Choose from AASHTO Type I, II, III, IV, V, VI)

Exterior Span Length (ft) Girder Spacing (ft)

First Interior Span Length (ft) Deck Thickness (in)

Second Interior Span Length (ft) Additional Dead Load (psf)

Ratio of Draped Length of Tendons to Span Length

Original RESTRAINT

5spans

Input Data for 5 span continuous girder

Select Girder Type (Enter I for I-Section and B for Box Section)

Exterior Span-I Length (ft) Girder Spacing (ft)

First Interior Span-I Length (ft) Deck Thickness (in)

Second Interior Span Length (ft) Additional Dead Load (psf)

First Interior Span-II Length (ft) Ratio of Draped Length of Tendons to Span Length

Exterior Span-II Length (ft)

Modified mRESTRAINT

Figure B-2

Allowing unsymmetric span lengths for bridges with more than two spans.

strandata5

Strand Data

Centroid of straight strands (in)

Centroid of draped strands at girder end (in)

Centroid of draped strands at midspan (in)

Number of straight strands

Number of draped strands

Cross sectional area of each strand

Initial strand tension (psi)

Type of strand : SR for Stress Relieved
LL for Low Relaxation

Modulus of elasticity of prestressing strand

Original RESTRAINT

strandata5

Strand Data

	Span - I	Span - II	Span - III	Span - IV	Span - V
Centroid of straight strands (in)	<input type="text" value="3.43"/>	<input type="text" value="3.43"/>	<input type="text" value="3.43"/>	<input type="text" value="3.43"/>	<input type="text" value="3.43"/>
Centroid of draped strands at girder end (in)	<input type="text" value="50"/>	<input type="text" value="50"/>	<input type="text" value="50"/>	<input type="text" value="50"/>	<input type="text" value="50"/>
Centroid of draped strands at midspan (in)	<input type="text" value="4"/>	<input type="text" value="4"/>	<input type="text" value="4"/>	<input type="text" value="4"/>	<input type="text" value="4"/>
Number of straight strands	<input type="text" value="22"/>	<input type="text" value="22"/>	<input type="text" value="22"/>	<input type="text" value="22"/>	<input type="text" value="22"/>
Number of draped strands	<input type="text" value="9"/>	<input type="text" value="9"/>	<input type="text" value="9"/>	<input type="text" value="9"/>	<input type="text" value="9"/>
Cross sectional area of each strand	<input type="text" value="0.217"/>	<input type="text" value="0.217"/>	<input type="text" value="0.217"/>	<input type="text" value="0.217"/>	<input type="text" value="0.217"/>
Initial strand tension (psi)	<input type="text" value="202765"/>	<input type="text" value="202765"/>	<input type="text" value="202765"/>	<input type="text" value="202765"/>	<input type="text" value="202765"/>
Type of strand : SR for Stress Relieved LL for Low Relaxation	<input type="text" value="LL"/>	<input type="text" value="LL"/>	<input type="text" value="LL"/>	<input type="text" value="LL"/>	<input type="text" value="LL"/>
Modulus of elasticity of prestressing strand					<input type="text" value="28500"/>

Modified mRESTRAINT

Figure B-3

Introducing different strand configurations for each span length..

output5

Output for 5 span continuous girder

Calculate Restraint Moments (kip-ft)

Age of girder(days)	at first interior supports	at second interior supports
7500	846.369934	634.435258

Print Preview < Back Main Menu

Close window Graphical output

Original RESTRAINT

output5

Output for 5 span continuous girder

Calculate Restraint Moments (kip-ft)

Age of girder(days)	at first interior support	at second interior support	at third interior support	at fourth interior support
20000	645.622615	217.899834	167.495091	624.921096

Print Preview < Back Main Menu

Close window Graphical output

Modified mRESTRAINT

Figure B-4

Resulting output for a five span bridge which also shows the age extension to 20000 days.

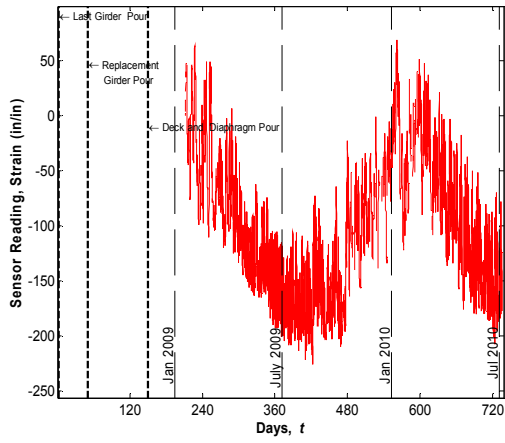
APPENDIX C

Recorded Readings from All Sensors

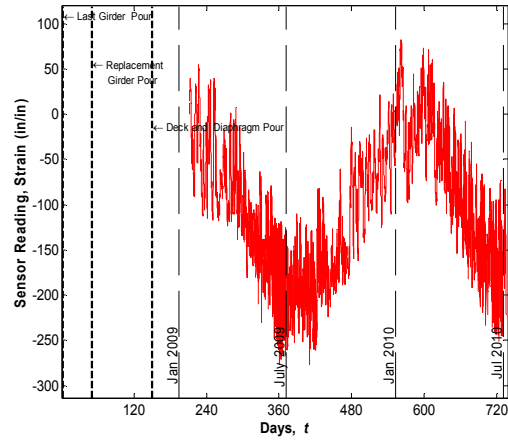
The following plots are a documentation of all sensor readings obtained during the monitoring period of the project June 18, 2008 through September 30, 2010. It should be noted that these records are not temperature corrected.

*** Will be updated before end of project ***

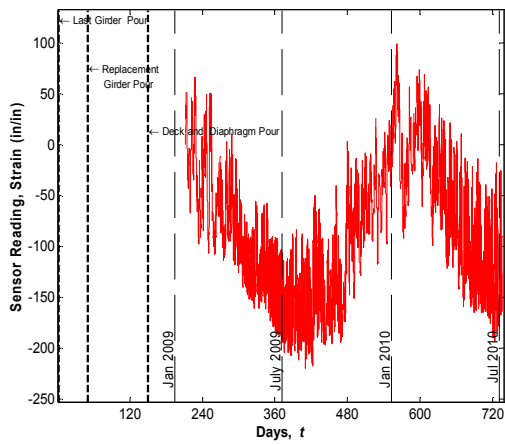
DRAFT



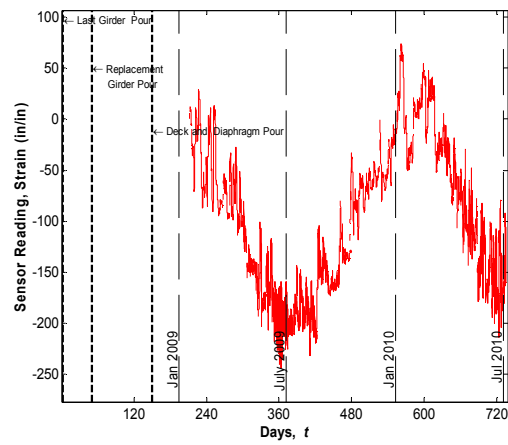
Sensor No. 1, Location G1S24, Support Bottom (Strandmeter)



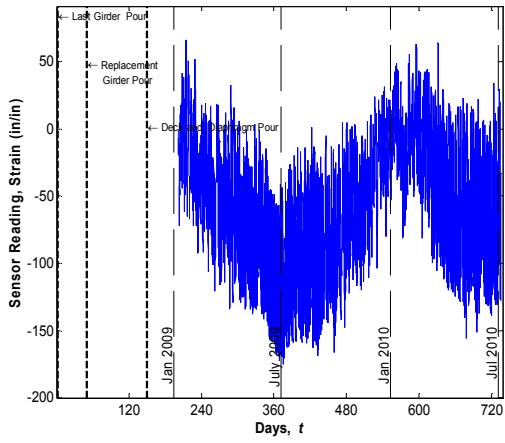
Sensor No. 2, Location G1S24, Support Bottom (Strandmeter)



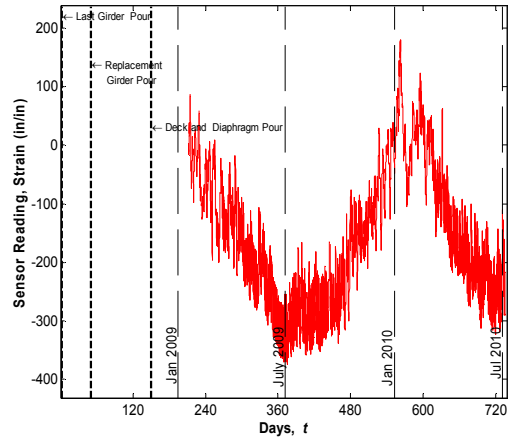
Sensor No. 3, Location G1S23, Support Bottom (Strandmeter)



Sensor No. 4, Location G1S23, Support Bottom (Strandmeter)

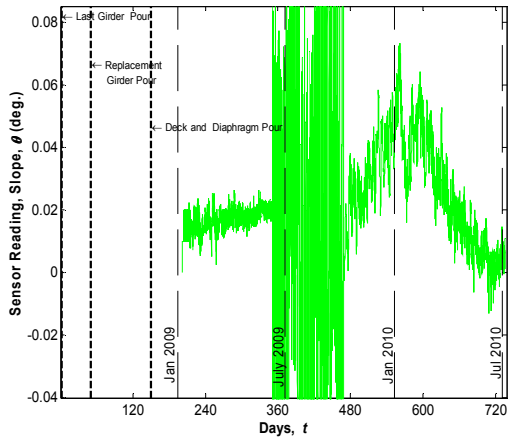


Sensor No. 5, Location G1S24, Support Top (Sisterbar)

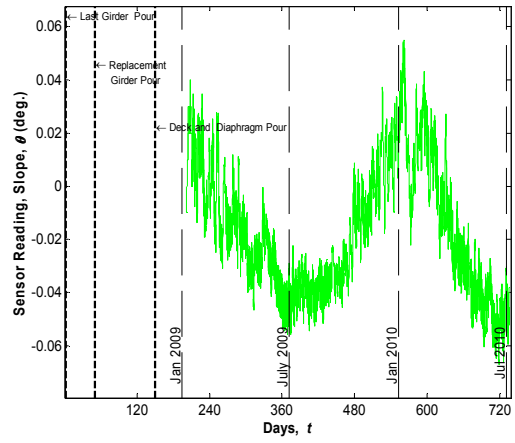


Sensor No. 6, Location G2S24, Support Top (Strandmeter)

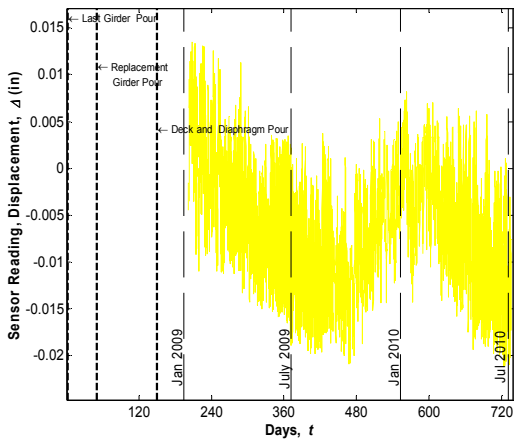
DRAFT



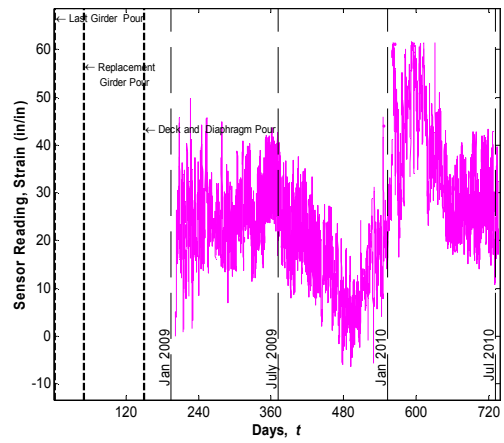
Sensor No. 7, Location G1S24, Support
(Tiltmeter)



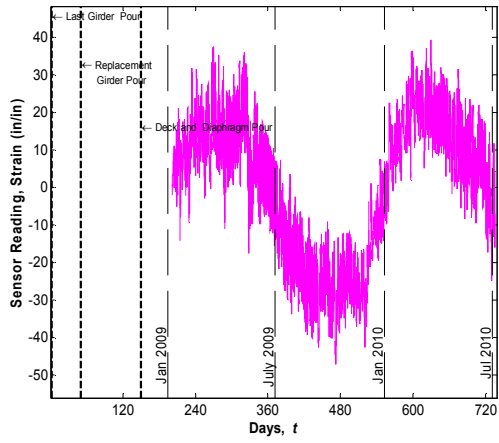
Sensor No. 8, Location G1S23, Support
(Tiltmeter)



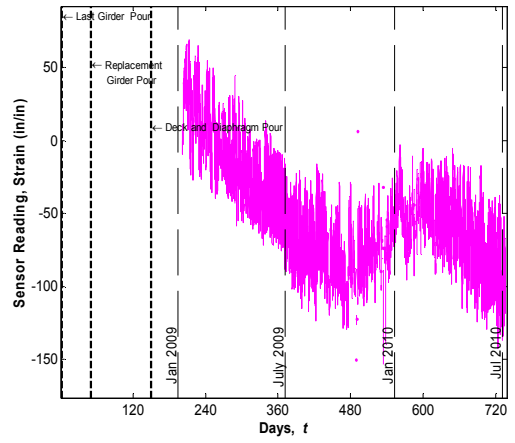
Sensor No. 9, Location G1, End Connection
(Displacement meter)



Sensor No. 17, Location G1S24, Support Top
(Vibrating wire gauge)

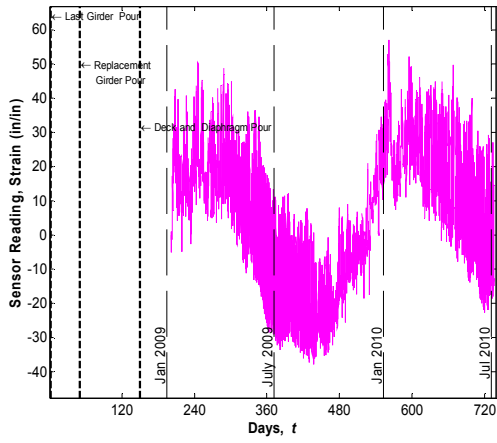


Sensor No. 18, Location G1S24, Support Middle
(Vibrating wire gauge)

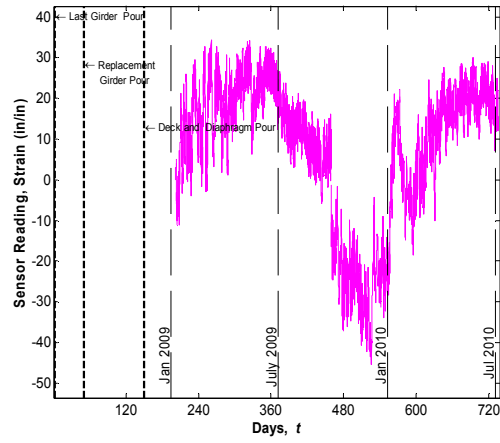


Sensor No. 19, Location G1S24, Support Bottom
(Vibrating wire gauge)

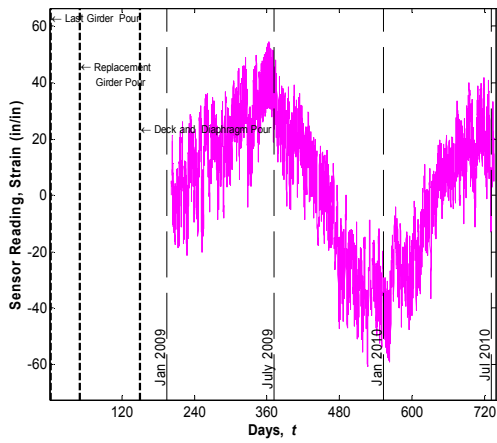
DRAFT



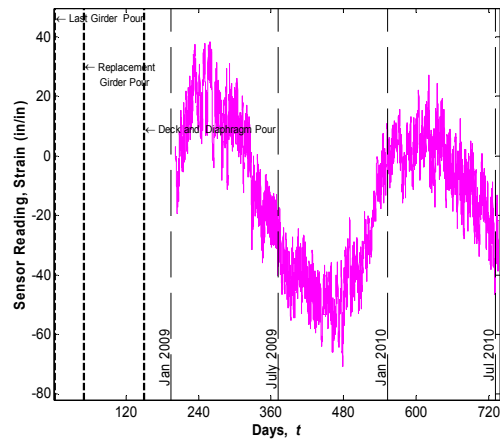
Sensor No. 33, Location G5S24, Support Top
(Vibrating wire gauge)



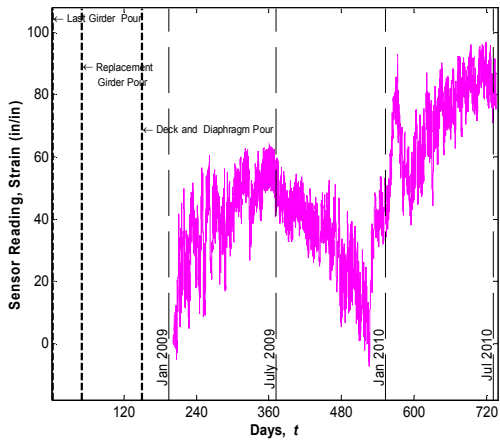
Sensor No. 34, Location G5S24, Support Middle
(Vibrating wire gauge)



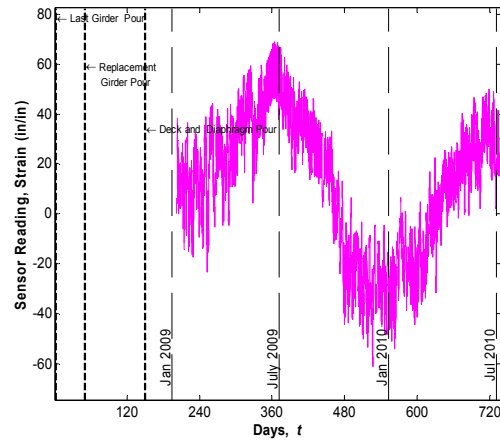
Sensor No. 35, Location G5S24, Support Bottom
(Vibrating wire gauge)



Sensor No. 36, Location G5S23, Support Top
(Vibrating wire gauge)

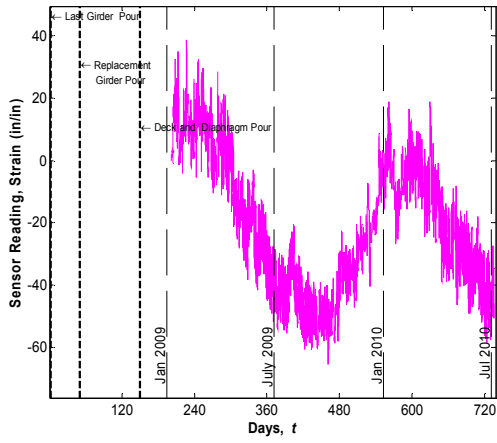


Sensor No. 37, Location G5S23, Support Middle
(Vibrating wire gauge)

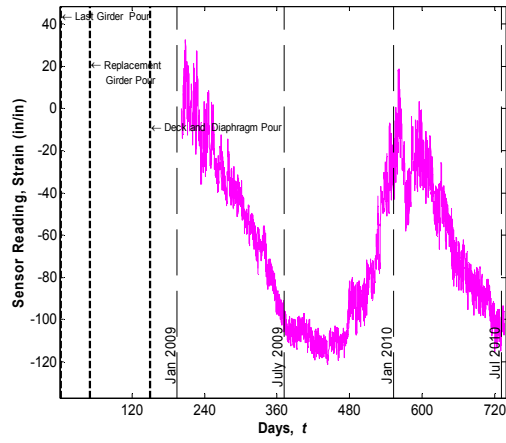


Sensor No. 38, Location G5S23, Support Bottom
(Vibrating wire gauge)

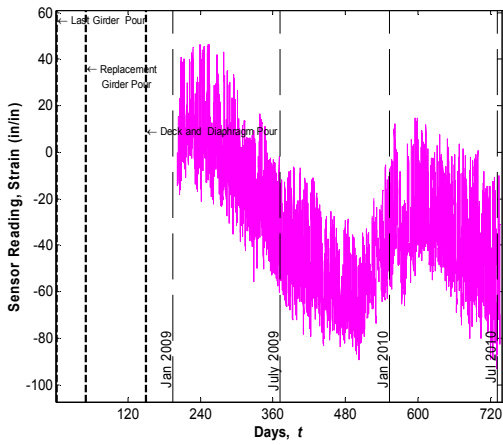
DRAFT



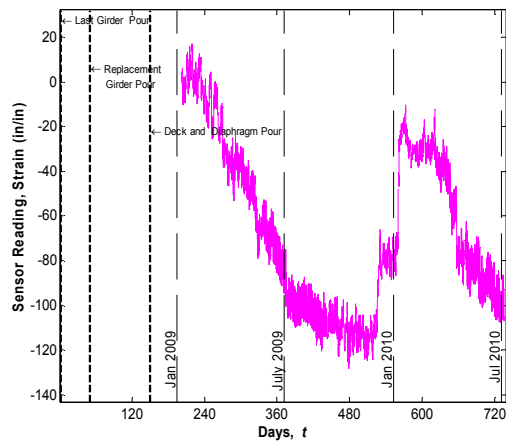
Sensor No. 39, Location G3S24, Support Top
(Vibrating wire gauge)



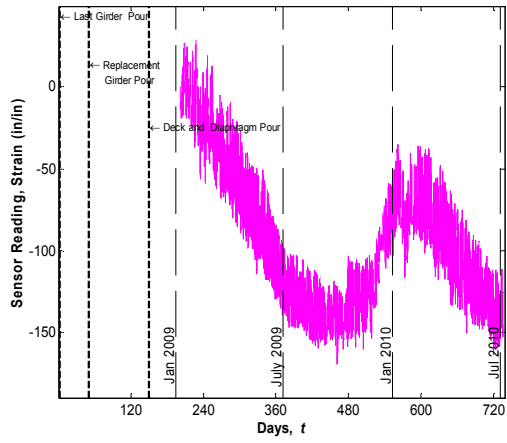
Sensor No. 40, Location G3S24, Support Middle
(Vibrating wire gauge)



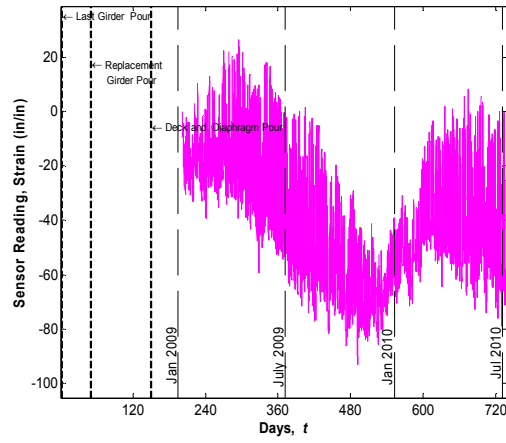
Sensor No. 41, Location G3S24, Support Bottom
(Vibrating wire gauge)



Sensor No. 42, Location G3S23, Support Top
(Vibrating wire gauge)

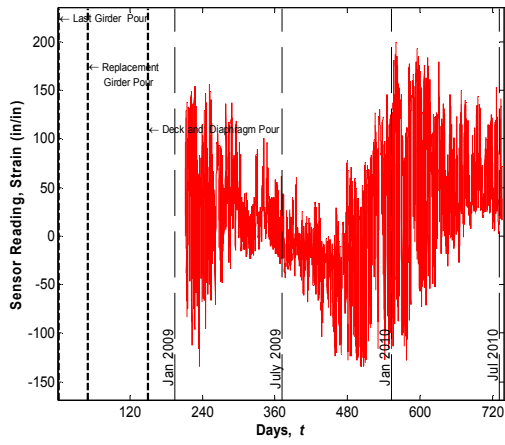


Sensor No. 43, Location G3S23, Support Middle
(Vibrating wire gauge)

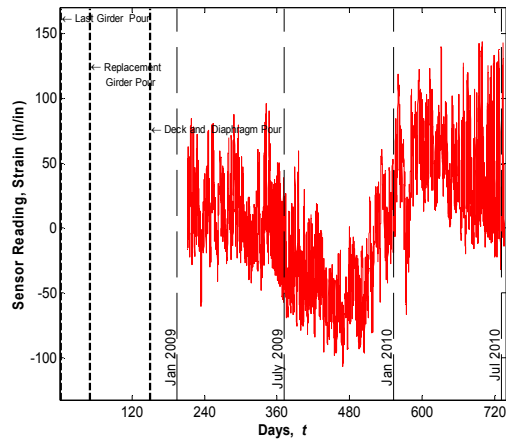


Sensor No. 44, Location G3S23, Support Bottom
(Vibrating wire gauge)

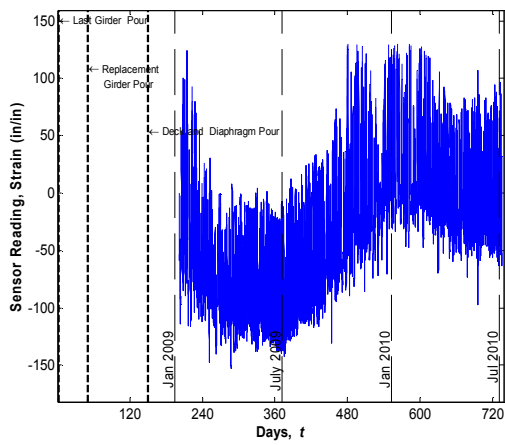
DRAFT



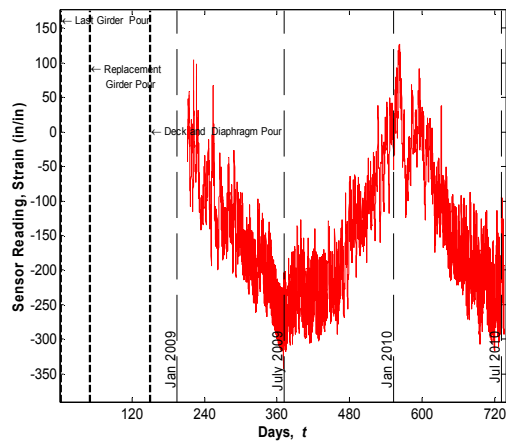
Sensor No. 45, Location G5S24, Support Bottom (Strandmeter)



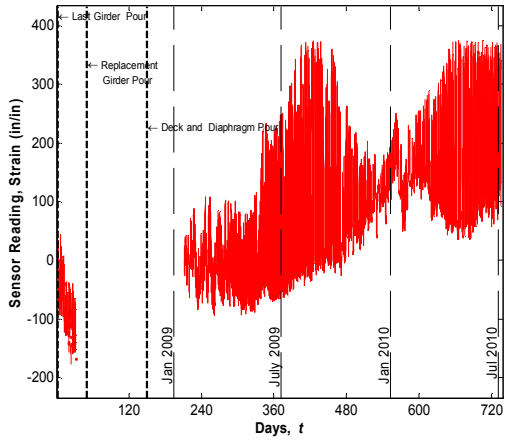
Sensor No. 46, Location G5S24, Support Bottom (Strandmeter)



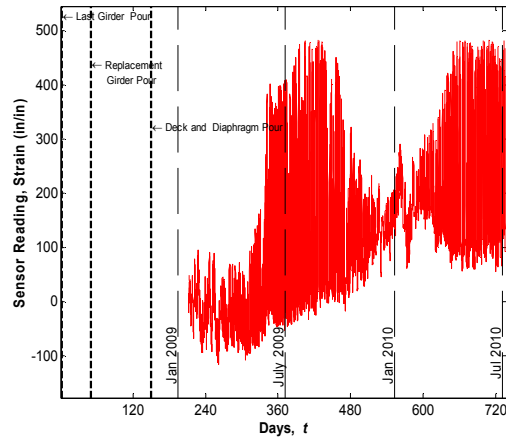
Sensor No. 47, Location G5S24, Support Top (Sisterbar)



Sensor No. 48, Location G4S24, Support Top (Strandmeter)

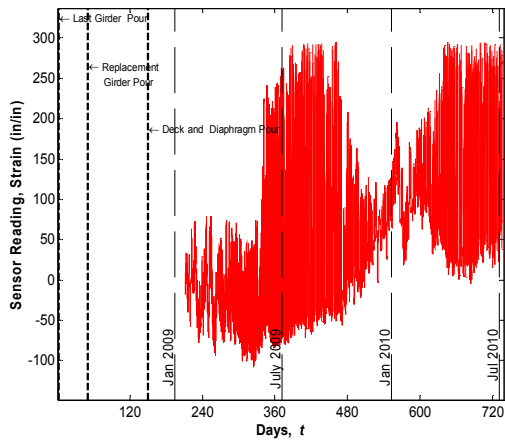


Sensor No. 49, Location G3S24, Support Bottom (Strandmeter)

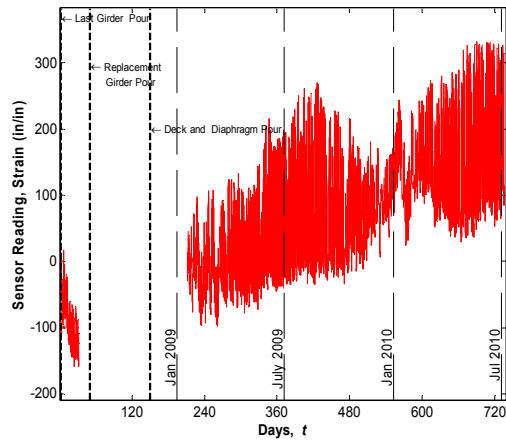


Sensor No. 50, Location G3S23, Support Bottom (Strandmeter)

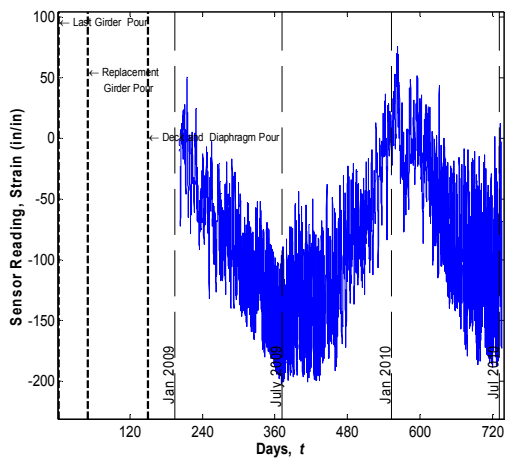
DRAFT



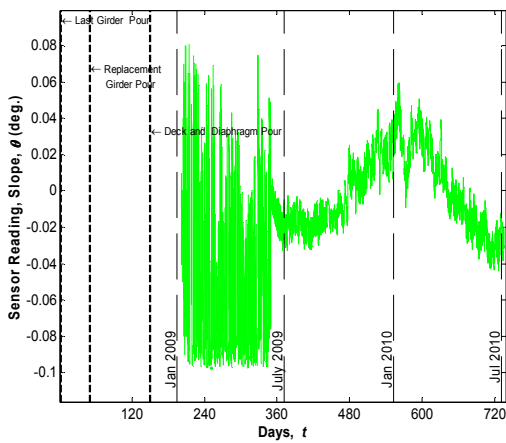
Sensor No. 51, Location G3S23, Support Bottom (Strandmeter)



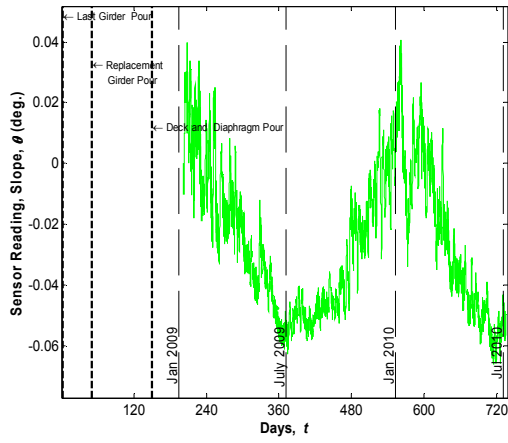
Sensor No. 52, Location G3S24, Support Bottom (Strandmeter)



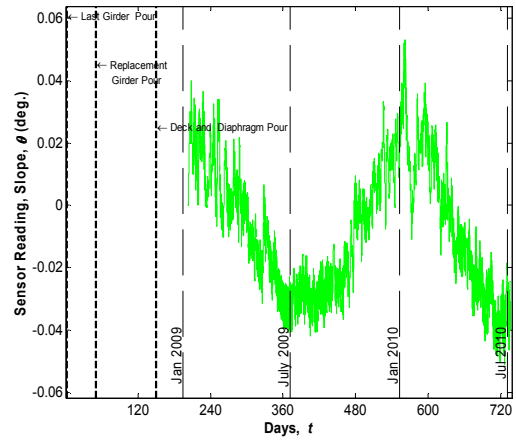
Sensor No. 53, Location G3S24, Support Top (Sisterbar)



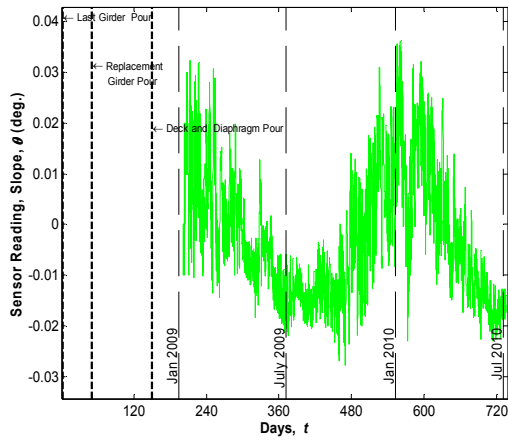
Sensor No. 54, Location G5S24, Support (Tiltmeter)



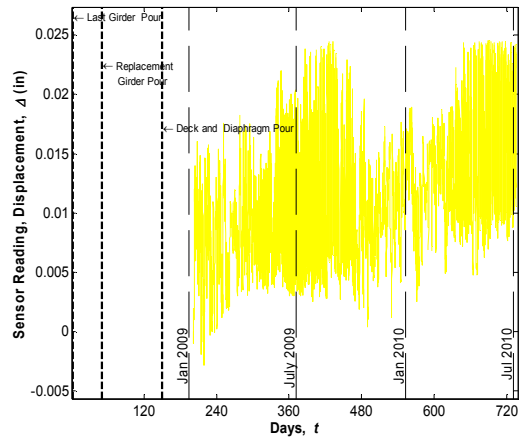
Sensor No. 55, Location G3S24, Support (Tiltmeter)



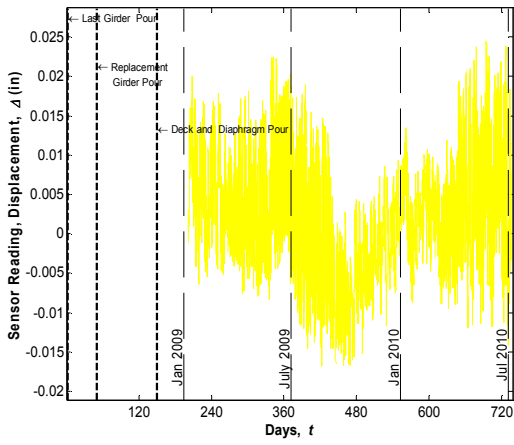
Sensor No. 56, Location G3S23, Support (Tiltmeter)



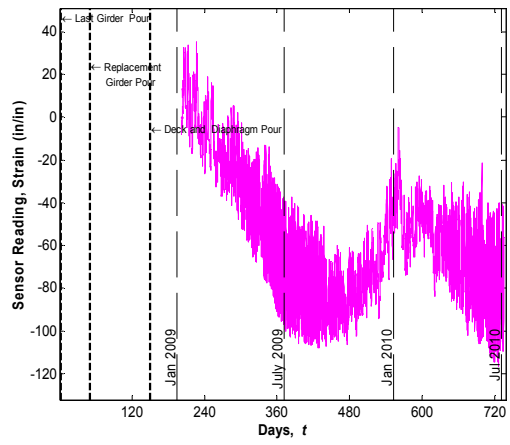
Sensor No. 57, Location G5S23, Support (Tiltmeter)



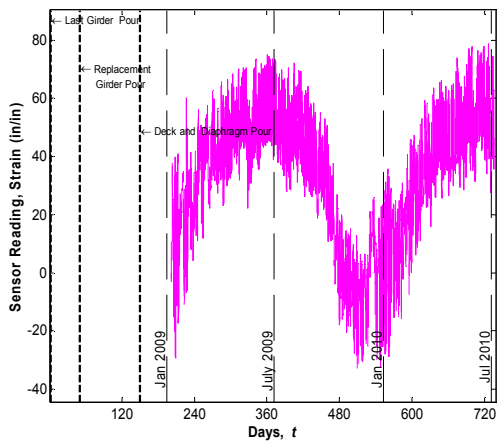
Sensor No. 58, Location G3, End Connection (Displacement meter)



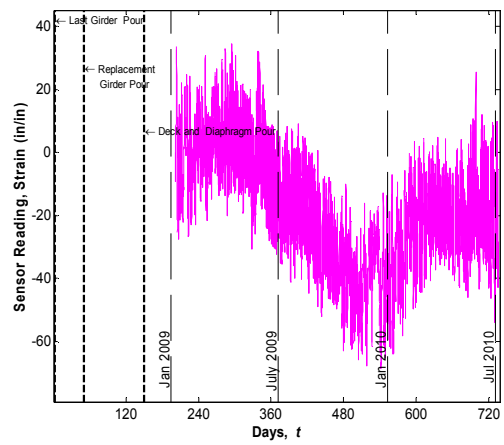
Sensor No. 59, Location G5, End Connection
(Displacement meter)



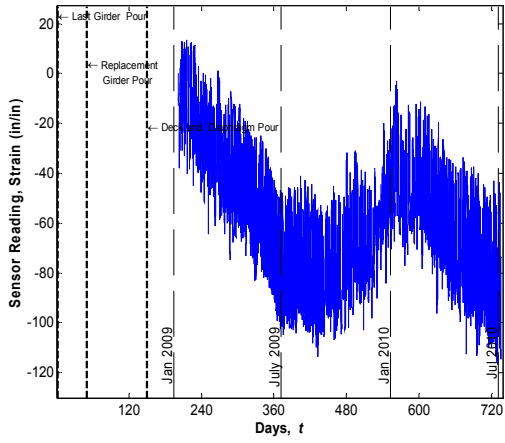
Sensor No. 65, Location G5S24, Midspan Top
(Vibrating wire gauge)



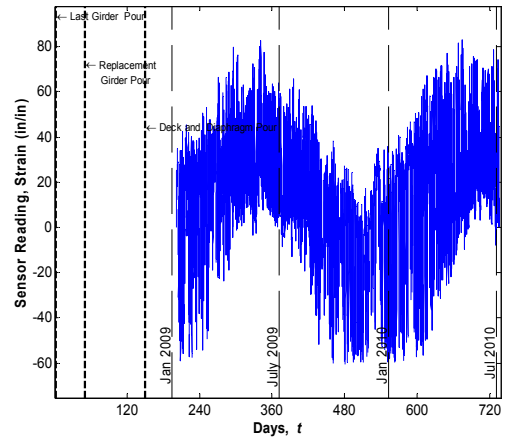
Sensor No. 66, Location G5S24, Midspan Middle
(Vibrating wire gauge)



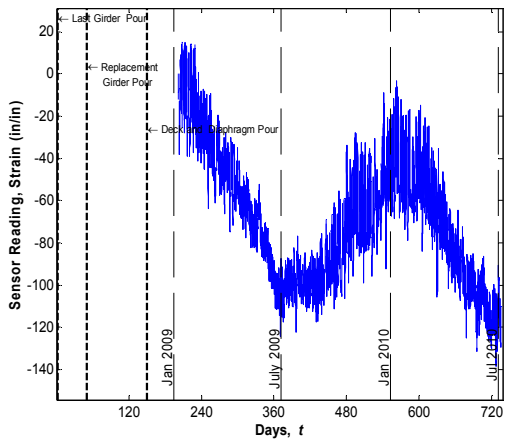
Sensor No. 67, Location G5S24, Midspan Bottom
(Vibrating wire gauge)



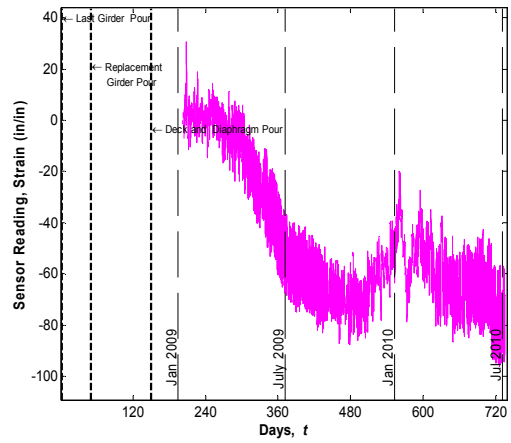
Sensor No. 68, Location G5S24, Midspan Top (Sisterbar)



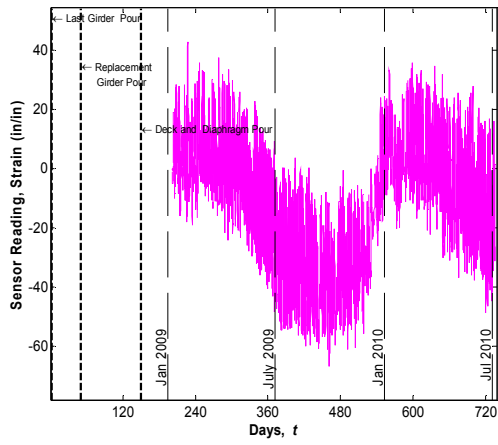
Sensor No. 69, Location G5S24, Midspan Bottom (Sisterbar)



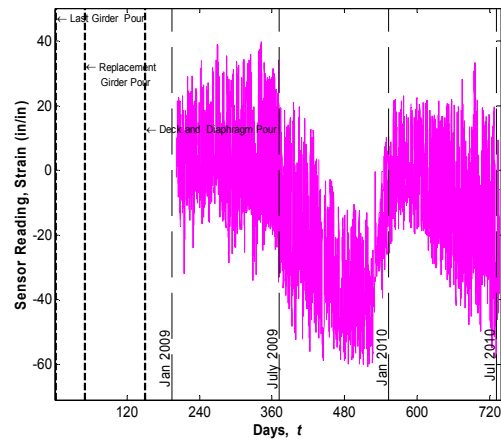
Sensor No. 70, Location G5S24, Midspan Deck (Sisterbar)



Sensor No. 81, Location G3S24, Midspan Top (Vibrating wire gauge)

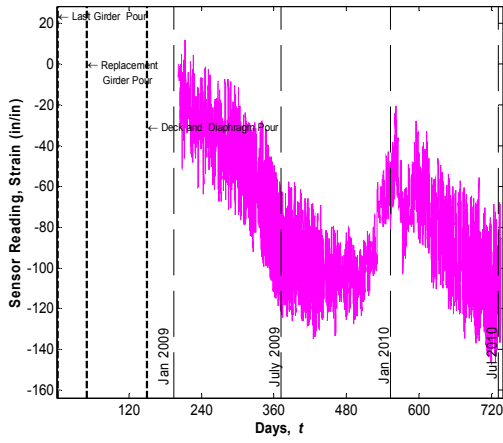


Sensor No. 82, Location G3S24, Midspan Middle
(Vibrating wire gauge)

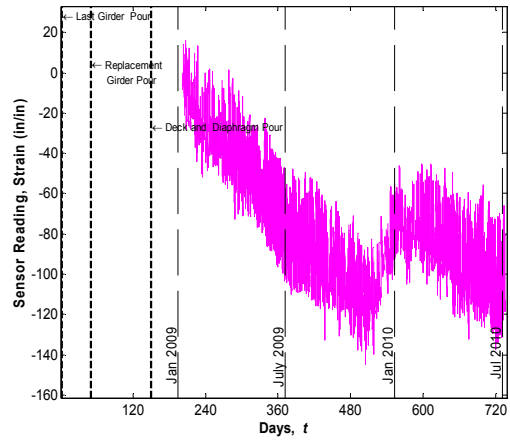


Sensor No. 83, Location G3S24, Midspan Bottom
(Vibrating wire gauge)

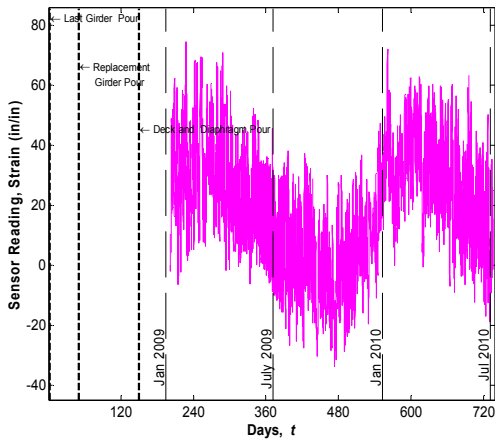
DRAFT



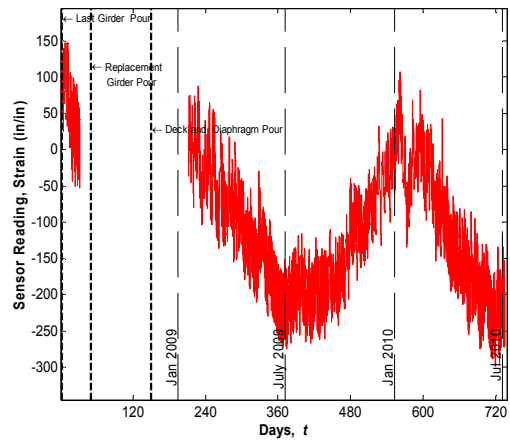
Sensor No. 84, Location G4S24, Midspan Top (Vibrating wire gauge)



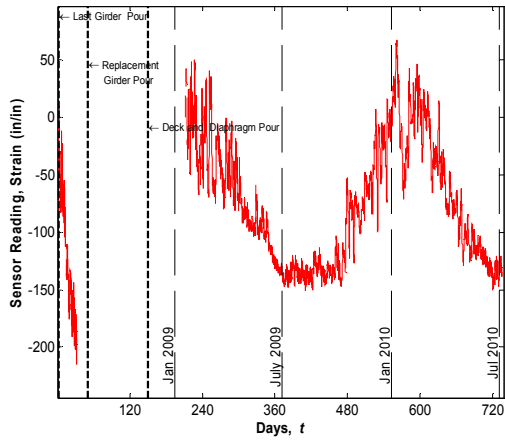
Sensor No. 85, Location G4S24, Midspan Middle (Vibrating wire gauge)



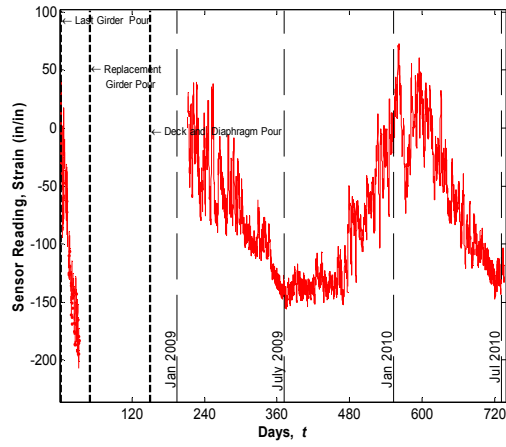
Sensor No. 86, Location G4S24, Midspan Bottom (Vibrating wire gauge)



Sensor No. 87, Location G4S24, Midspan Top (Strandmeter)

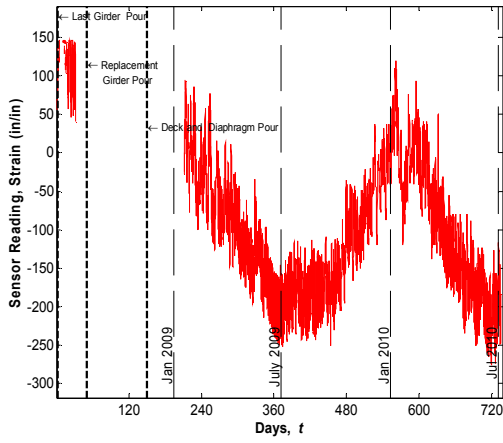


Sensor No. 88, Location G4S24, Midspan Bottom (Strandmeter)

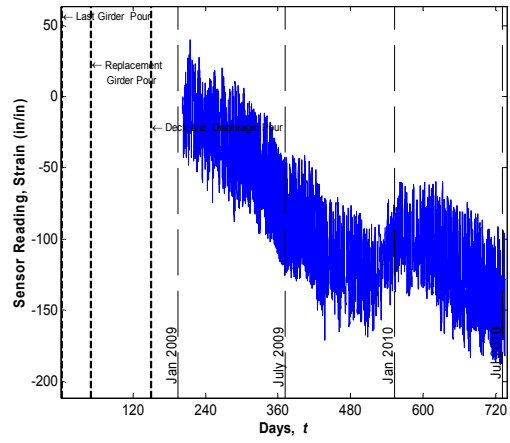


Sensor No. 89, Location G3S24, Midspan Bottom (Strandmeter)

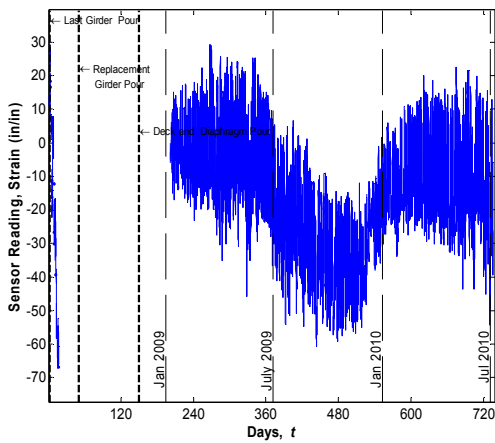
DRAFT



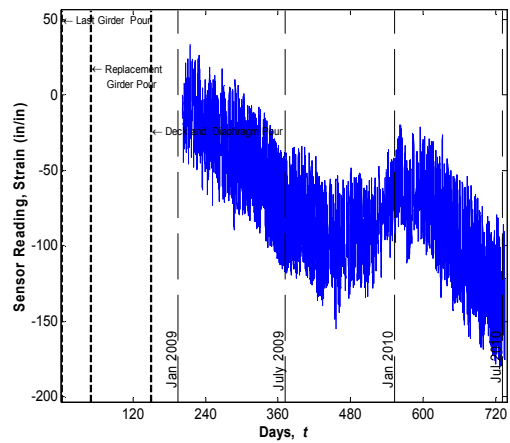
Sensor No. 90, Location G3S24, Midspan Top (Strandmeter)



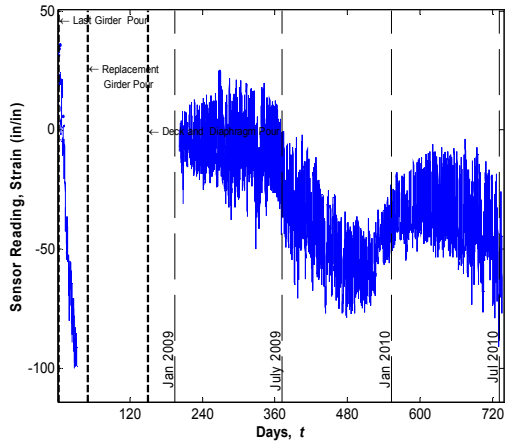
Sensor No. 91, Location G3S24, Midspan Top (Sisterbar)



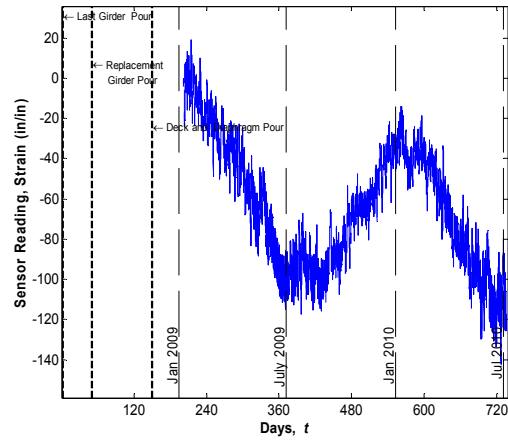
Sensor No. 92, Location G3S24, Midspan Bottom (Sisterbar)



Sensor No. 93, Location G4S24, Midspan Top (Sisterbar)

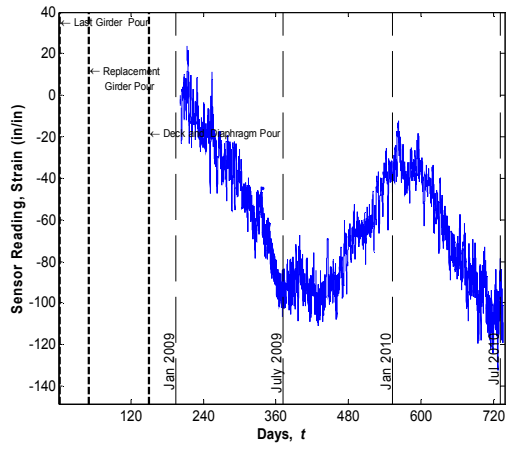


Sensor No. 94, Location G4S24, Midspan Bottom (Sisterbar)



Sensor No. 95, Location G3S24, Midspan Deck (Sisterbar)

DRAFT



Sensor No. 96, Location G4S24, Midspan Deck (Sisterbar)

DRAFT

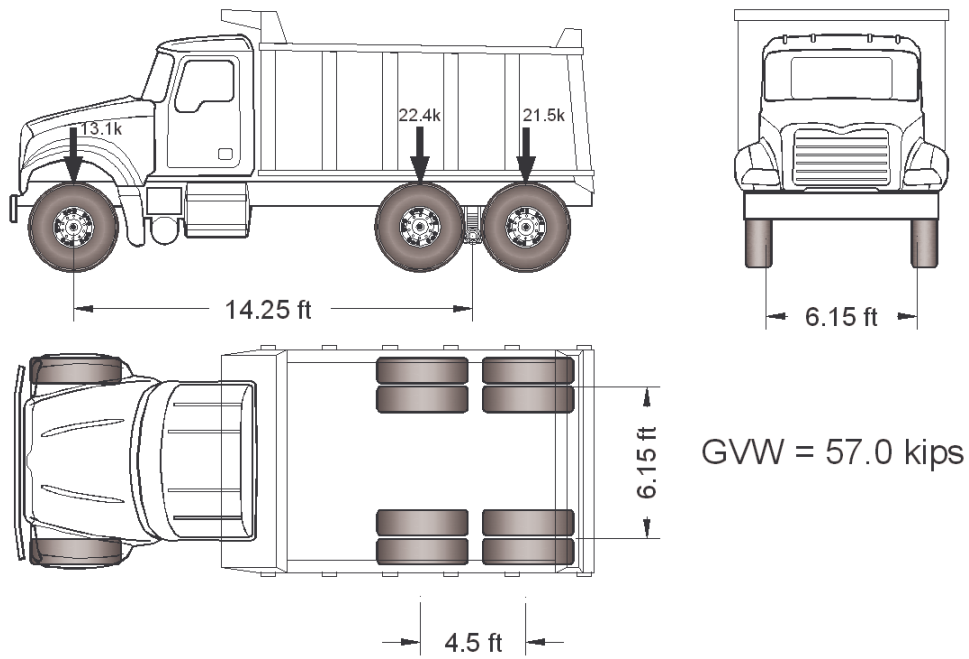
APPENDIX D

Dimensions and Weights of Trucks Used in Live Load Tests

Two dump trucks from the LA-DOTD maintenance office in New Roads, LA were used to load the monitored segment of Bridge #2 as described in Section XXX. The trucks were loaded before the tests and measurements of axle dimensions and weights were recorded. The research team measured the dimensions; while the Weights and Standards Police used using portable scales to weigh both trucks (see Figure D-1). Figure D-2 shows the recorded dimensions and axle weights for both trucks. The dimensions are almost identical for both trucks except for the fact that the distance between the front axle and rear axle group is longer for Truck #1 (156-227) by 3 in than Truck #2 (156-091). The gross vehicle weights were recorded to be 57.0 kips and 54.1 kips for Truck #1 and Truck #2, respectively.

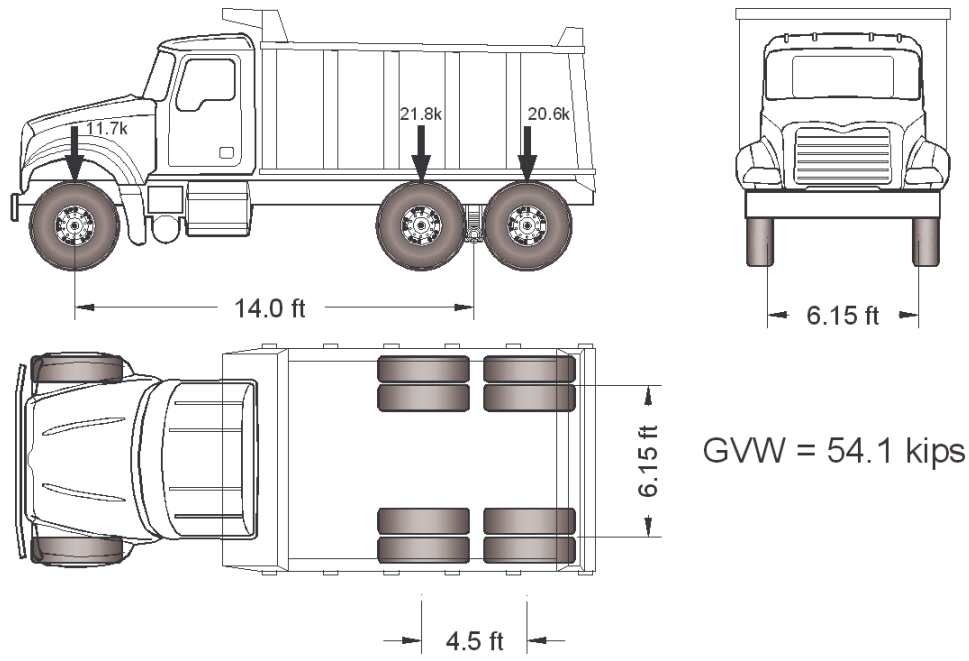


Figure D-1
Portable scales used in weighing individual truck axles.



GVW = 57.0 kips

(a) Truck #1 (156-227)



GVW = 54.1 kips

(a) Truck #2 (156-091)

Figure D-2
Dimensions and weights of trucks used in live load tests.

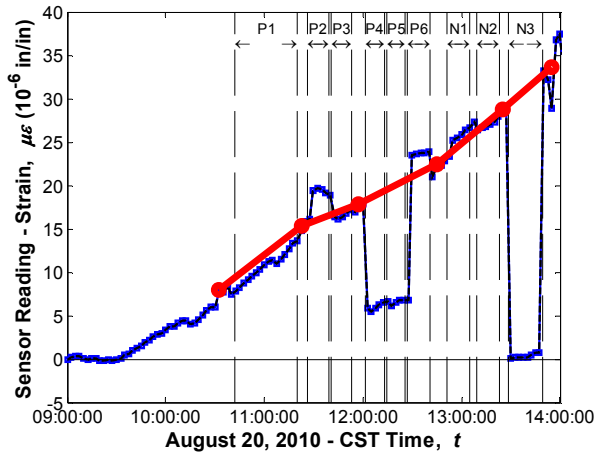
DRAFT

APPENDIX E

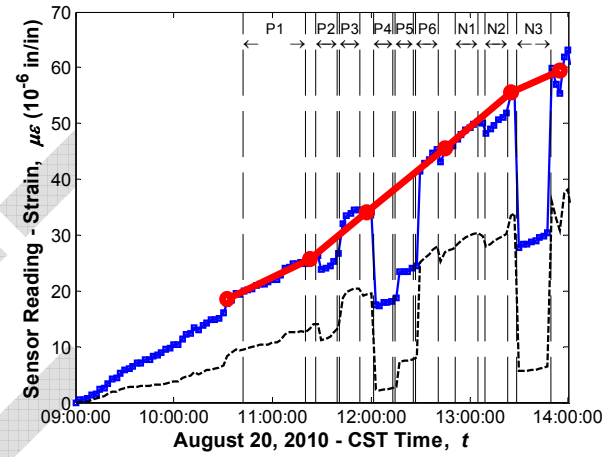
Plots of Sensor Readings During Static Live Load Tests

The following plots are a documentation of all sensor readings obtained during the static live load tests.

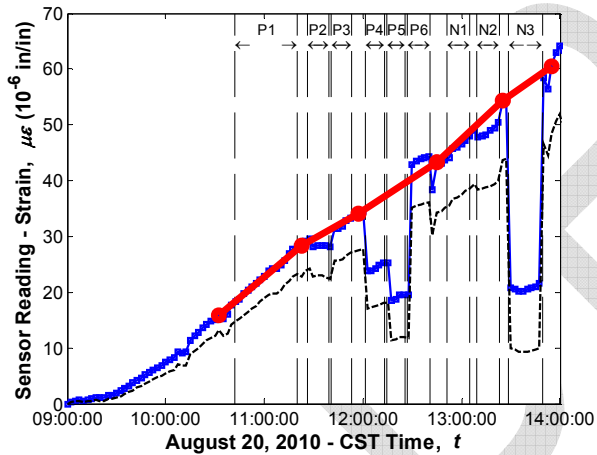
DRAFT



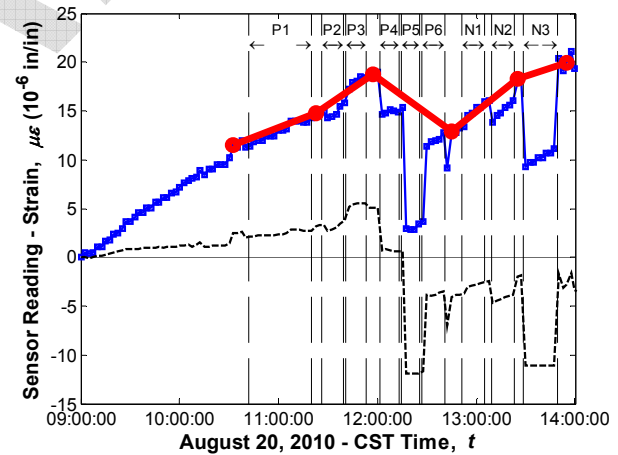
Sensor No. 1, Location G1S24, Support Bottom (Strandmeter)



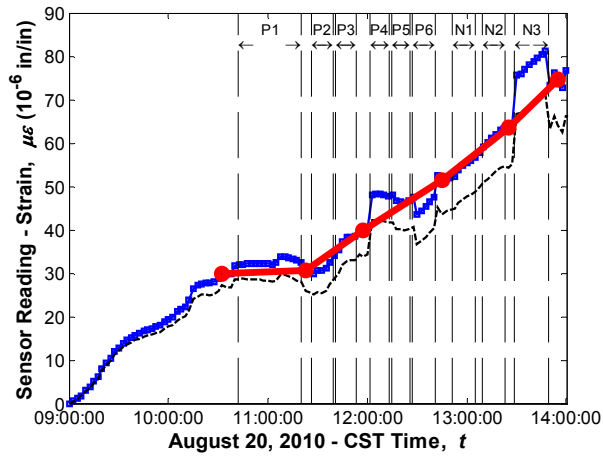
Sensor No. 2, Location G1S24, Support Bottom (Strandmeter)



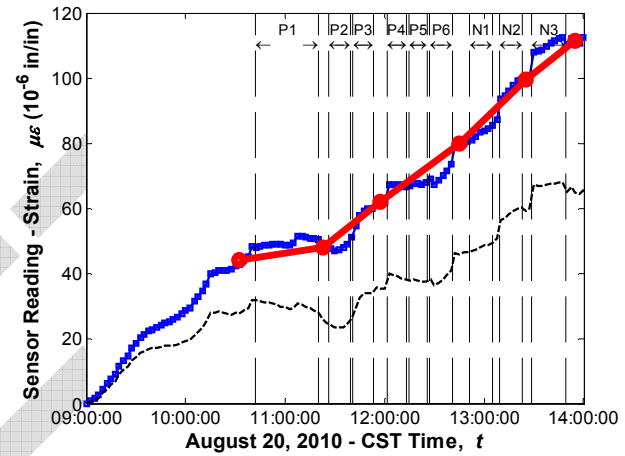
Sensor No. 3, Location G1S23, Support Bottom (Strandmeter)



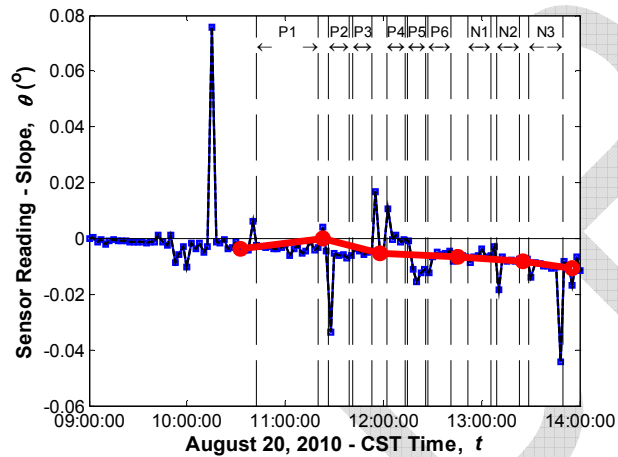
Sensor No. 4, Location G1S23, Support Bottom (Strandmeter)



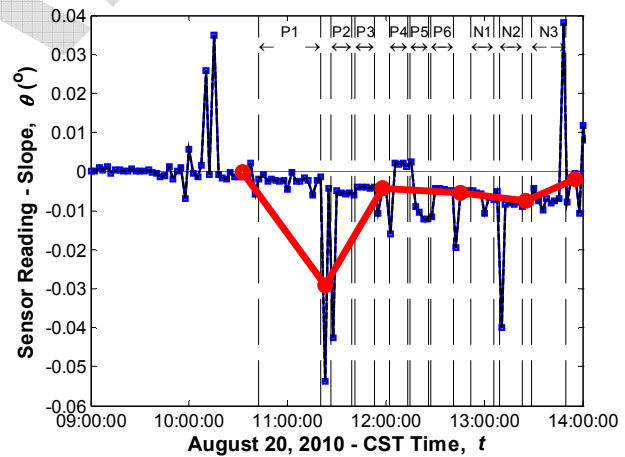
Sensor No. 5, Location G1S24, Support Top (Sisterbar)



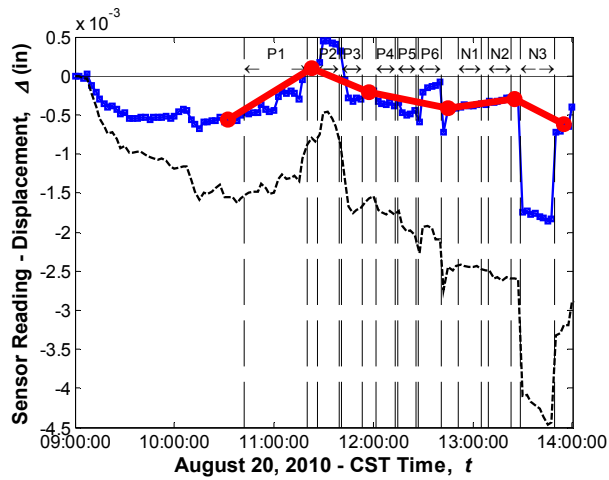
Sensor No. 6, Location G2S24, Support Top (Strandmeter)



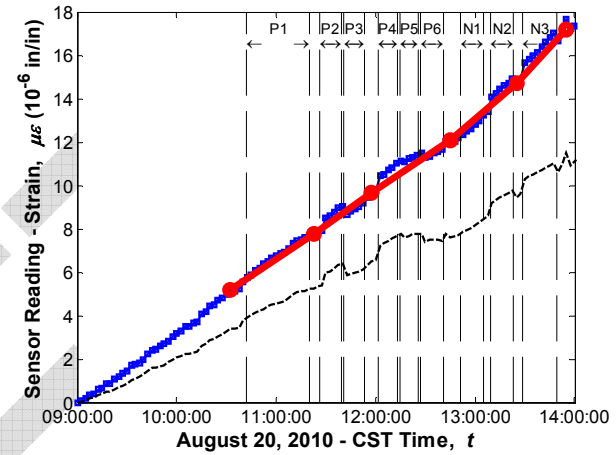
Sensor No. 7, Location G1S24, Support (Tiltmeter)



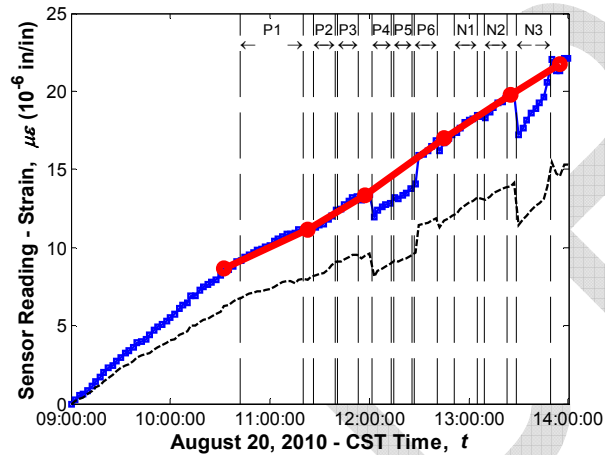
Sensor No. 8, Location G1S23, Support (Tiltmeter)



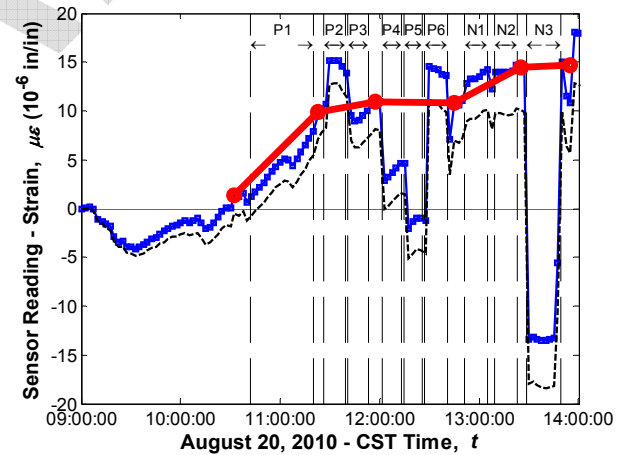
**Sensor No. 9, Location G1, End Connection
(Displacement meter)**



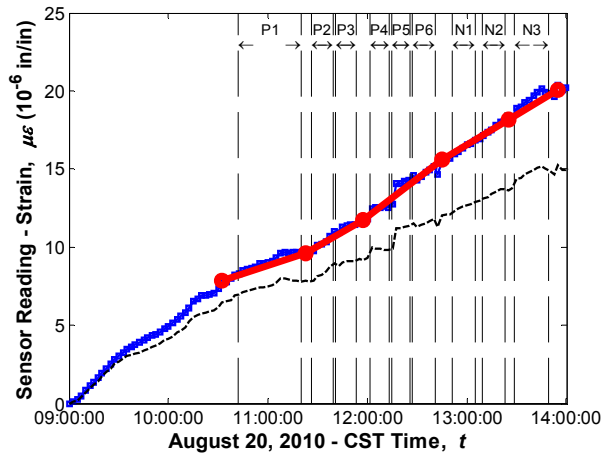
**Sensor No. 17, Location G1S24, Support Top
(Vibrating wire gauge)**



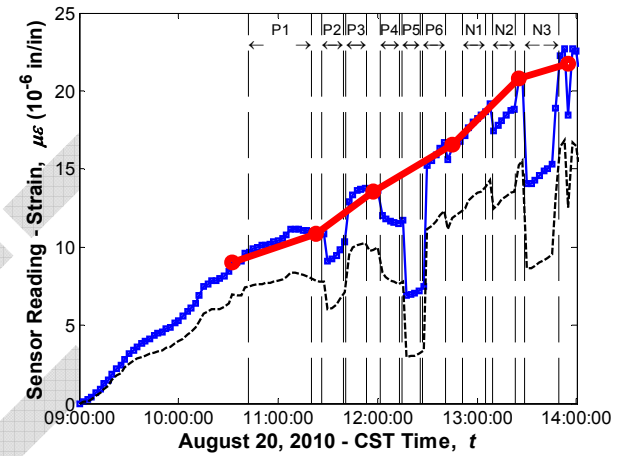
**Sensor No. 18, Location G1S24, Support Middle
(Vibrating wire gauge)**



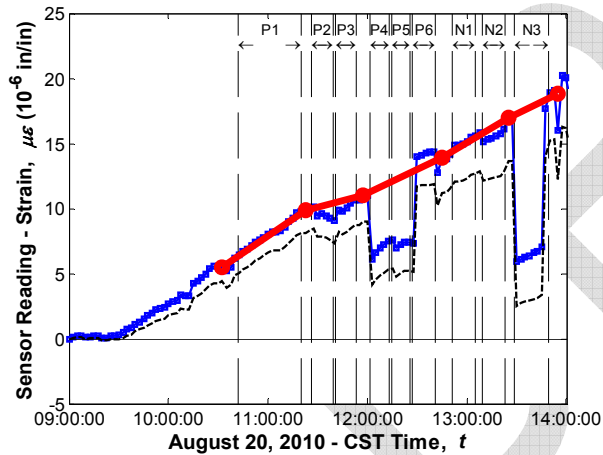
**Sensor No. 19, Location G1S24, Support Bottom
(Vibrating wire gauge)**



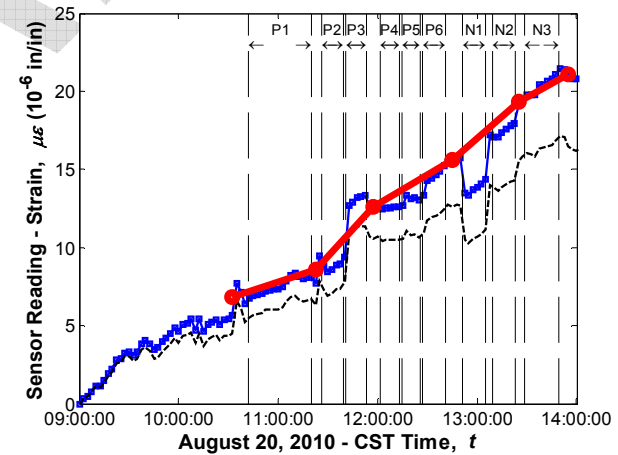
Sensor No. 20, Location G1S23, Support Top (Vibrating wire gauge)



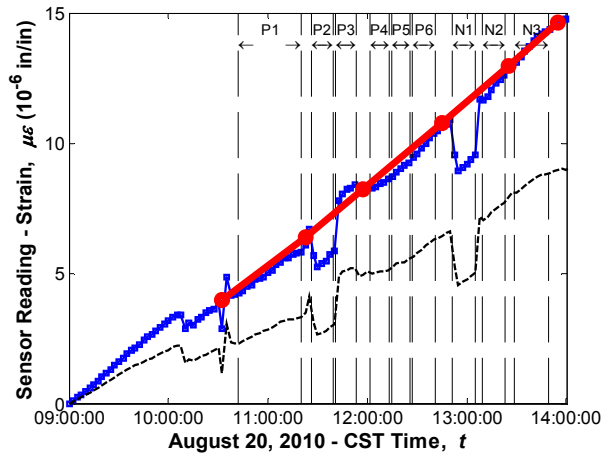
Sensor No. 21, Location G1S23, Support Middle (Vibrating wire gauge)



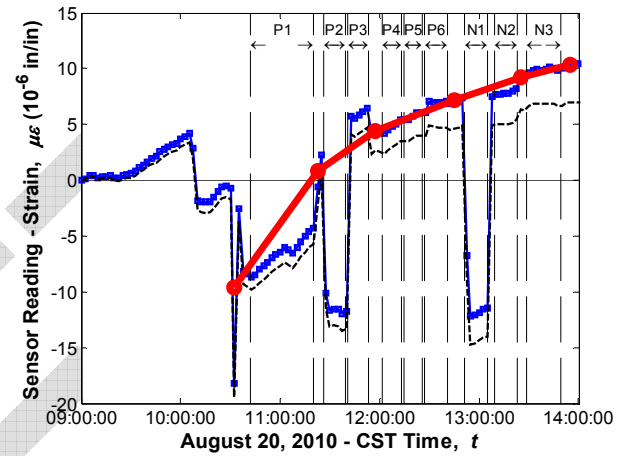
Sensor No. 22, Location G1S23, Support Bottom (Vibrating wire gauge)



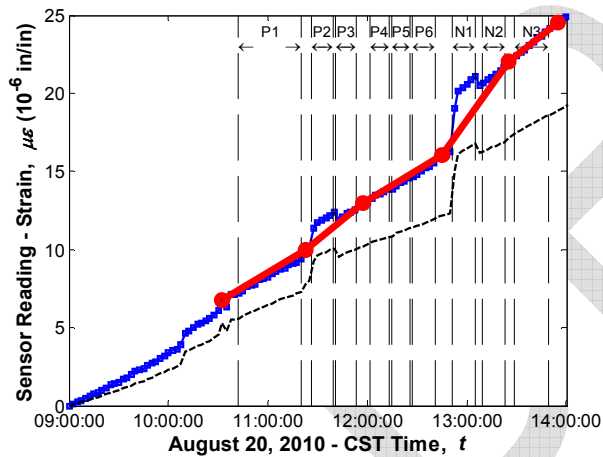
Sensor No. 33, Location G5S24, Support Top (Vibrating wire gauge)



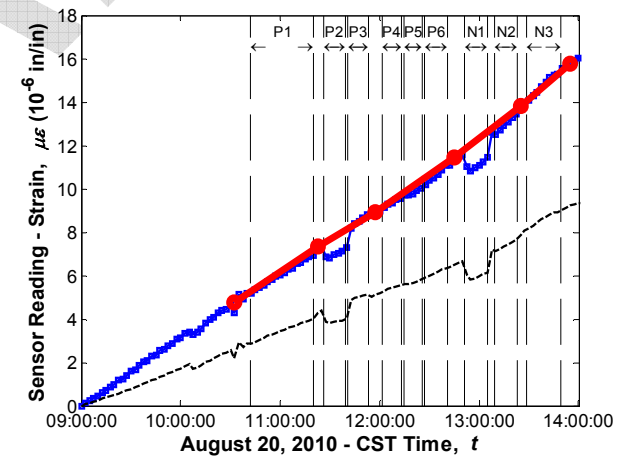
**Sensor No. 34, Location G5S24, Support Middle
(Vibrating wire gauge)**



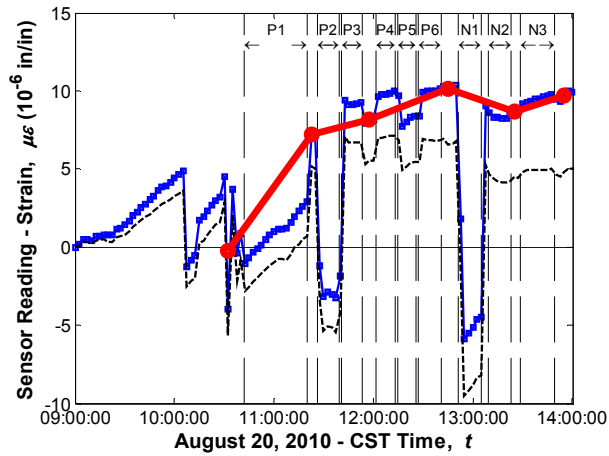
**Sensor No. 35, Location G5S24, Support Bottom
(Vibrating wire gauge)**



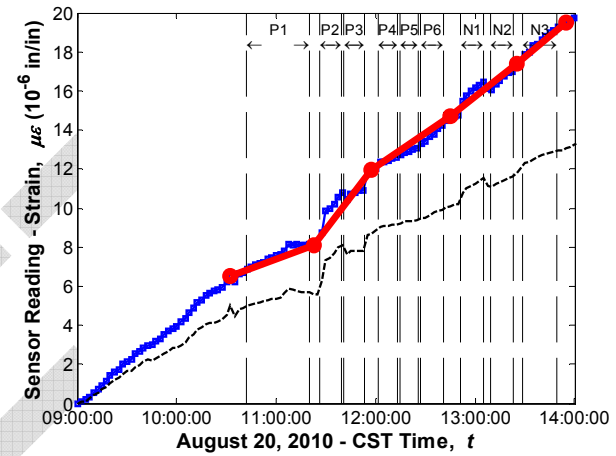
**Sensor No. 36, Location G5S23, Support Top
(Vibrating wire gauge)**



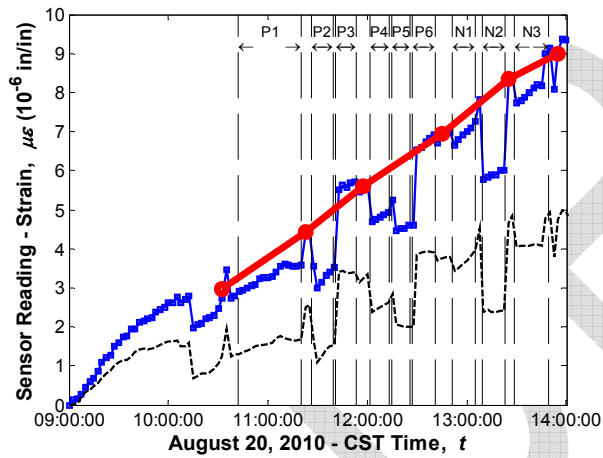
**Sensor No. 37, Location G5S23, Support Middle
(Vibrating wire gauge)**



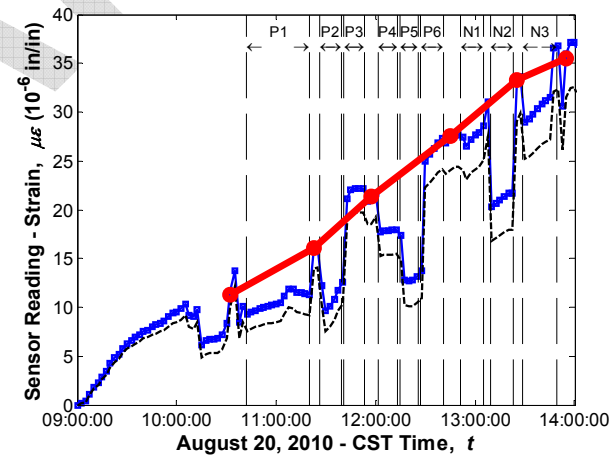
**Sensor No. 38, Location G5S23, Support Bottom
(Vibrating wire gauge)**



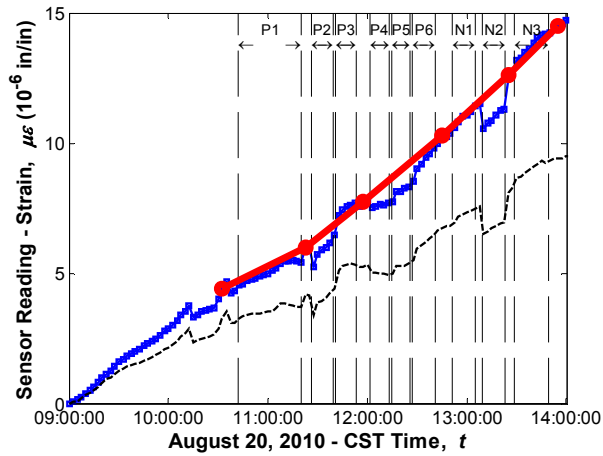
**Sensor No. 39, Location G3S24, Support Top (Vibrating
wire gauge)**



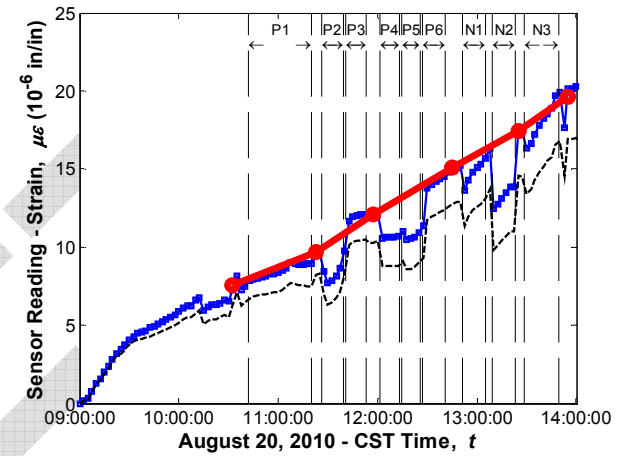
**Sensor No. 40, Location G3S24, Support Middle
(Vibrating wire gauge)**



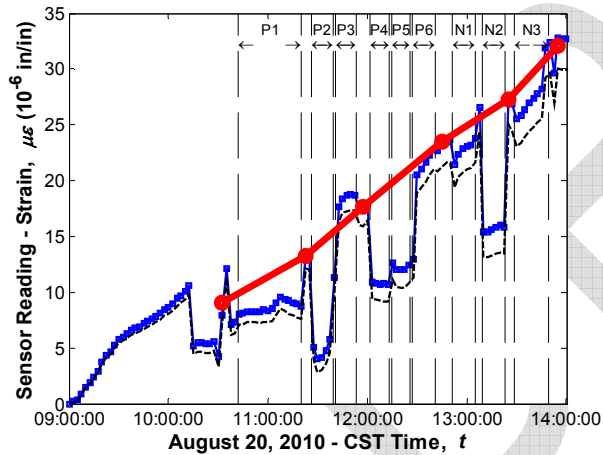
**Sensor No. 41, Location G3S24, Support Bottom
(Vibrating wire gauge)**



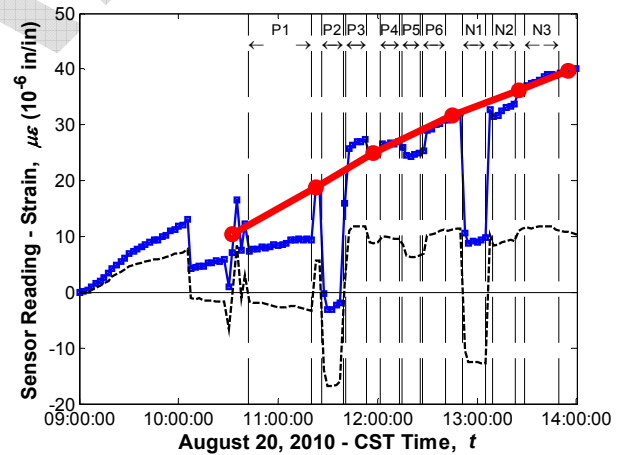
**Sensor No. 42, Location G3S23, Support Top
(Vibrating wire gauge)**



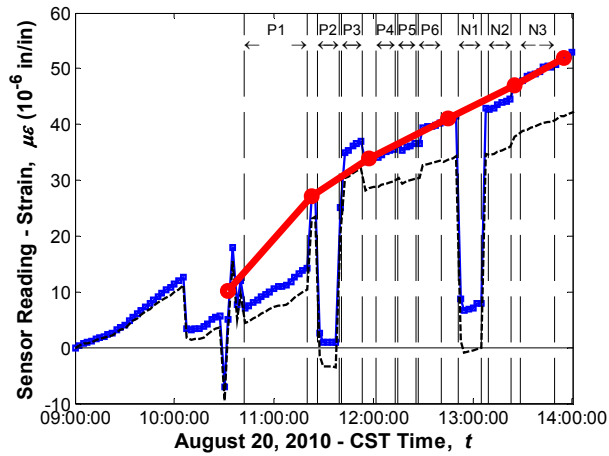
**Sensor No. 43, Location G3S23, Support Middle
(Vibrating wire gauge)**



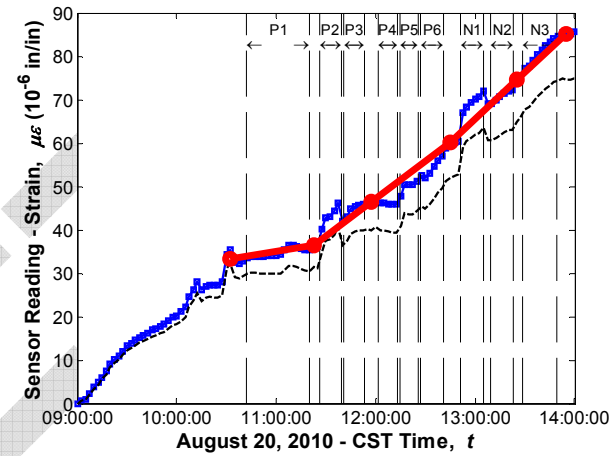
**Sensor No. 44, Location G3S23, Support Bottom
(Vibrating wire gauge)**



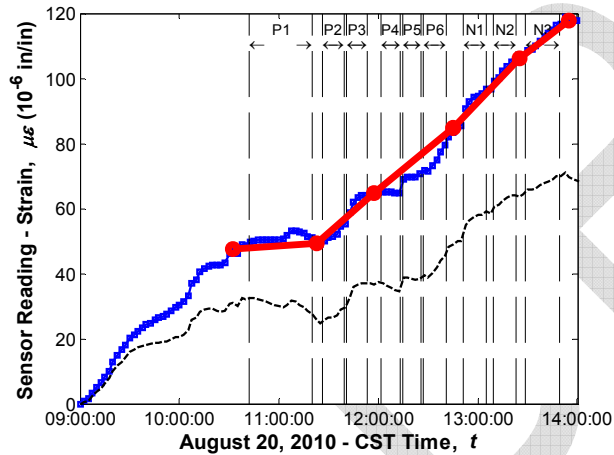
**Sensor No. 45, Location G5S24, Support Bottom
(Strandmeter)**



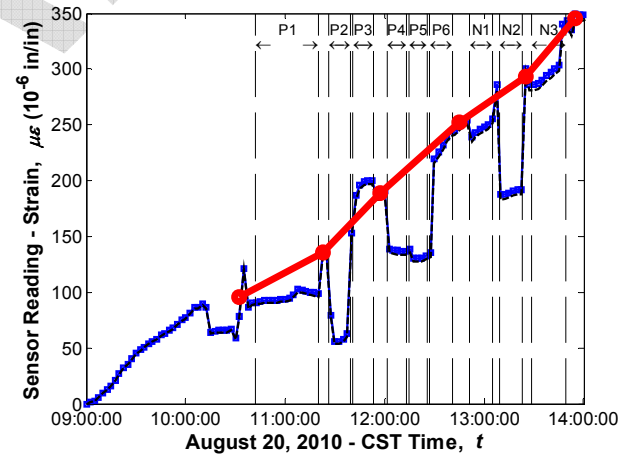
Sensor No. 46, Location G5S24, Support Bottom (Strandmeter)



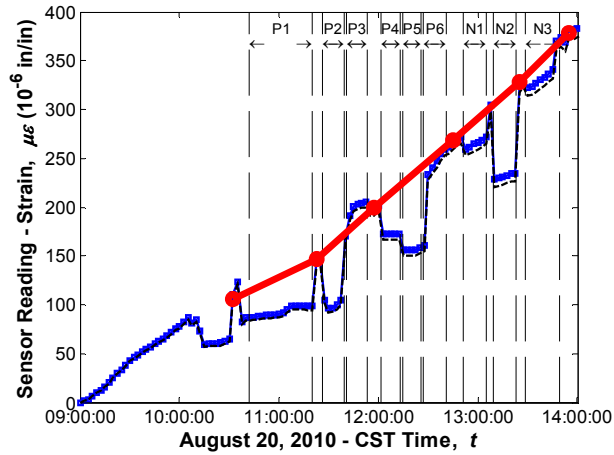
Sensor No. 47, Location G5S24, Support Top (Sisterbar)



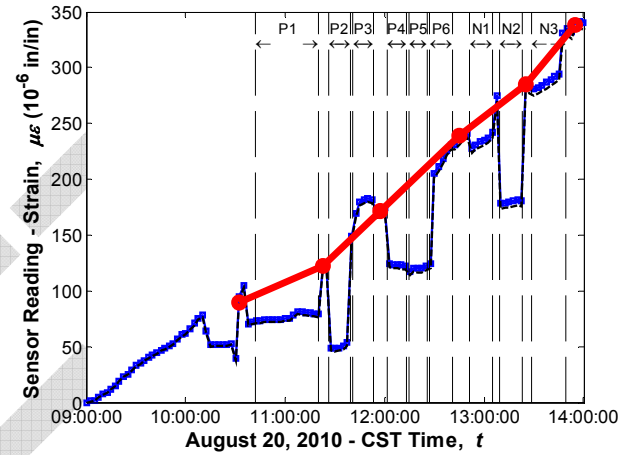
Sensor No. 48, Location G4S24, Support Top (Strandmeter)



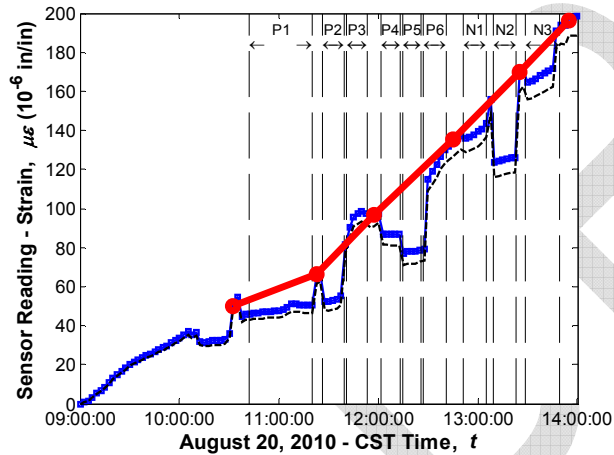
Sensor No. 49, Location G3S24, Support Bottom (Strandmeter)



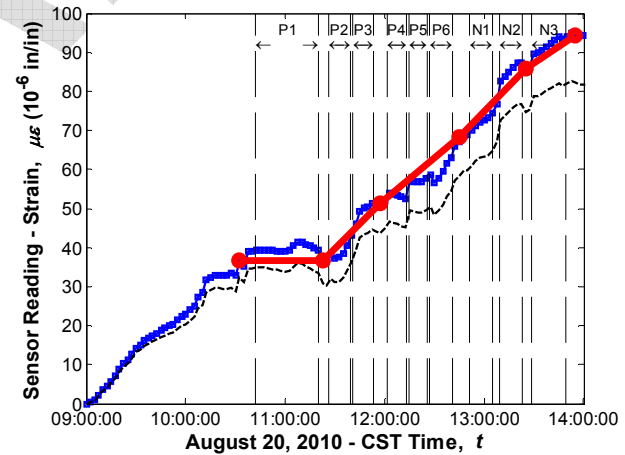
Sensor No. 50, Location G3S23, Support Bottom (Strandmeter)



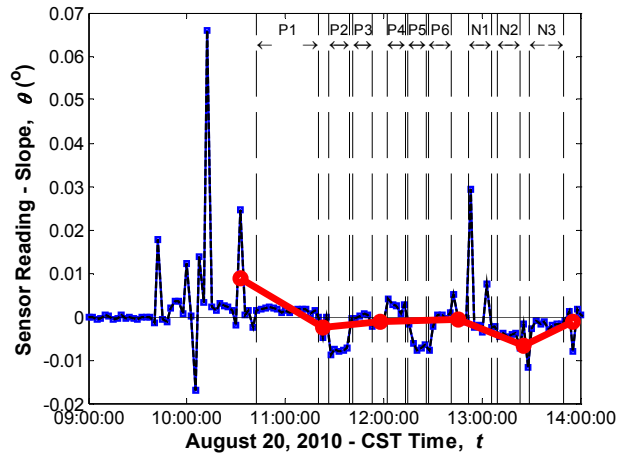
Sensor No. 51, Location G3S23, Support Bottom (Strandmeter)



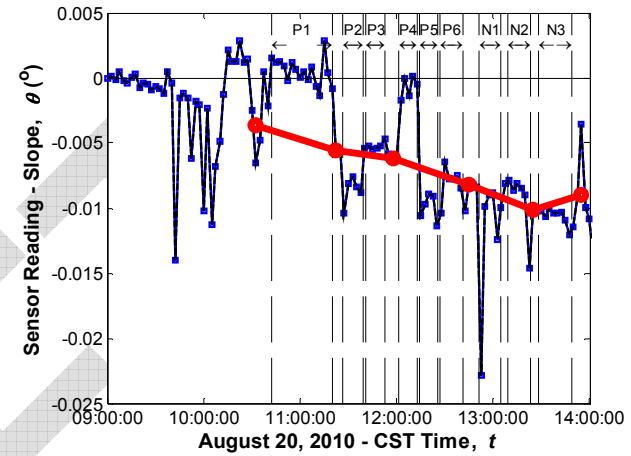
Sensor No. 52, Location G3S24, Support Bottom (Strandmeter)



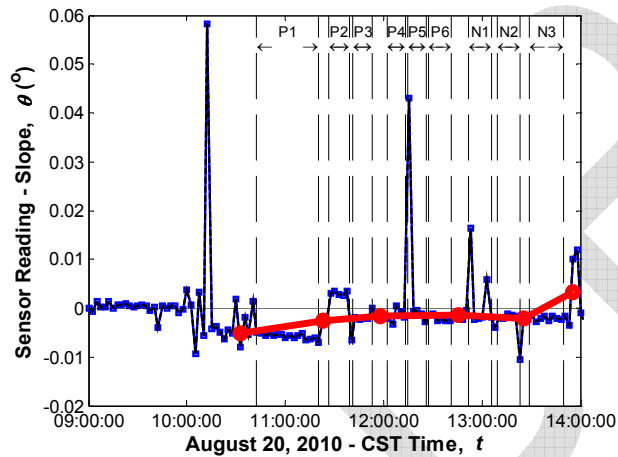
Sensor No. 53, Location G3S24, Support Top (Sisterbar)



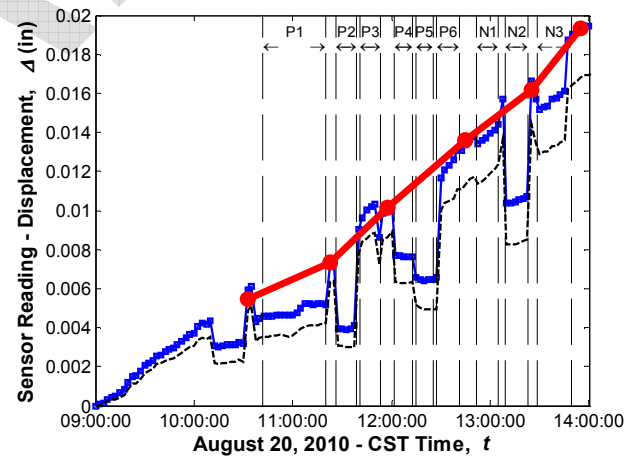
Sensor No. 55, Location G3S24, Support (Tiltmeter)



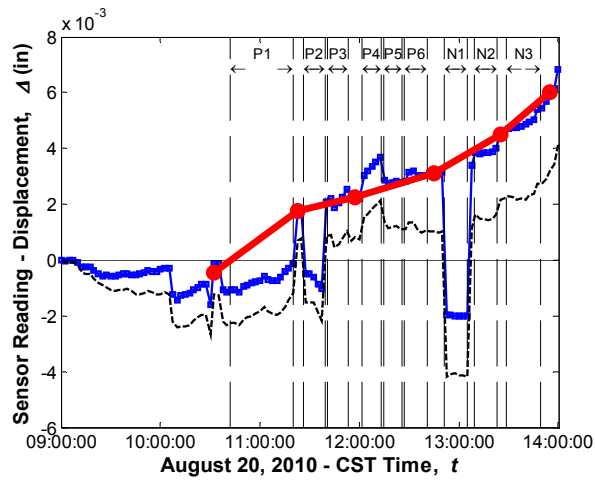
Sensor No. 56, Location G3S23, Support (Tiltmeter)



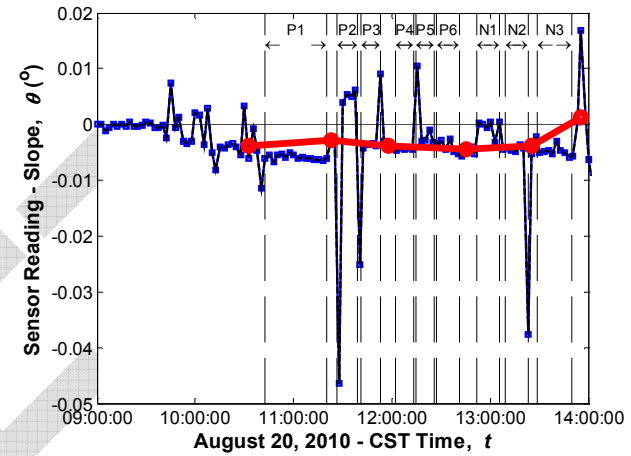
Sensor No. 57, Location G5S23, Support (Tiltmeter)



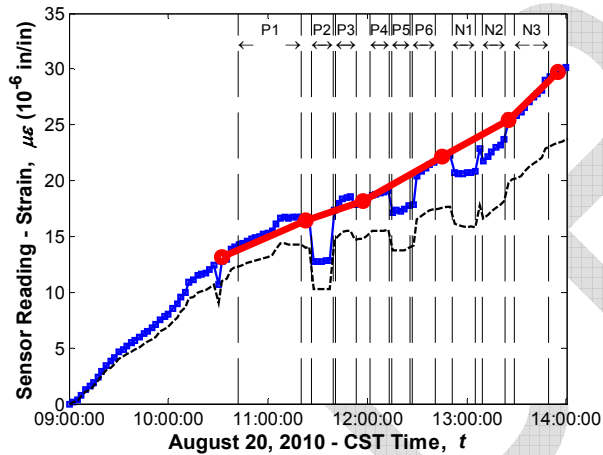
Sensor No. 58, Location G3, End Connection (Displacement meter)



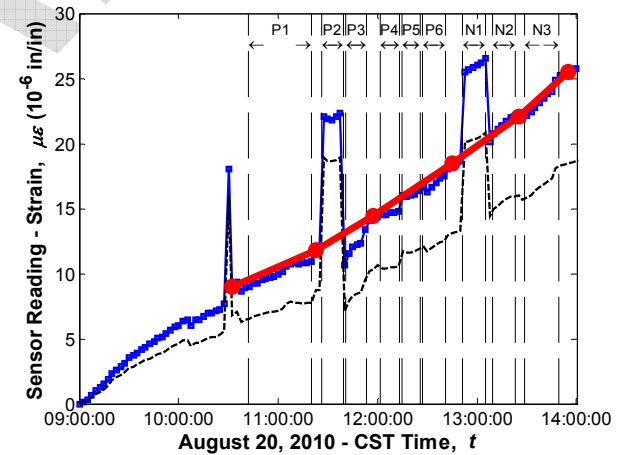
**Sensor No. 59, Location G5, End Connection
(Displacement meter)**



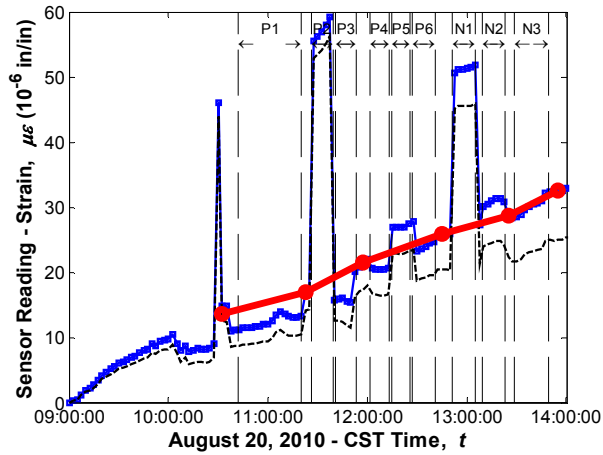
**Sensor No. 60, Location G5S24, Support
(Tiltmeter)**



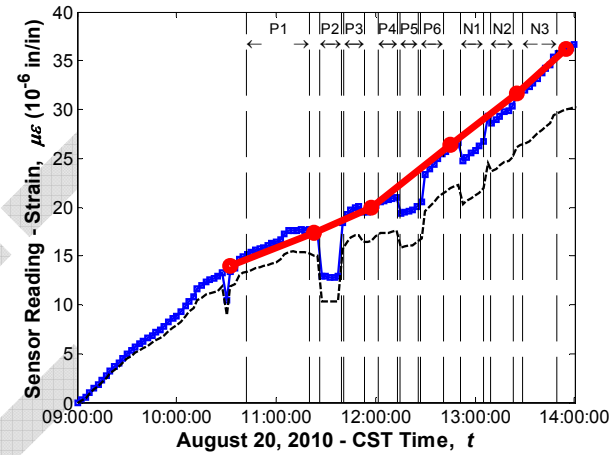
**Sensor No. 65, Location G5S24, Midspan Top (Vibrating
wire gauge)**



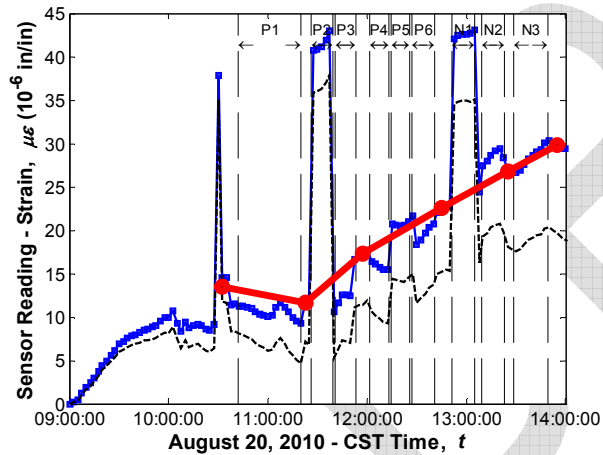
**Sensor No. 66, Location G5S24, Midspan Middle
(Vibrating wire gauge)**



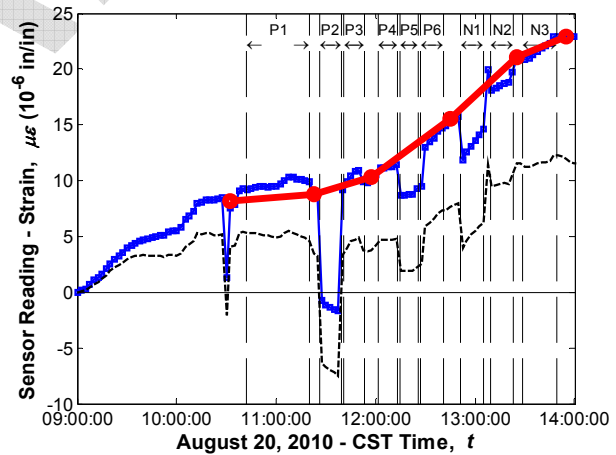
**Sensor No. 67, Location G5S24, Midspan Bottom
(Vibrating wire gauge)**



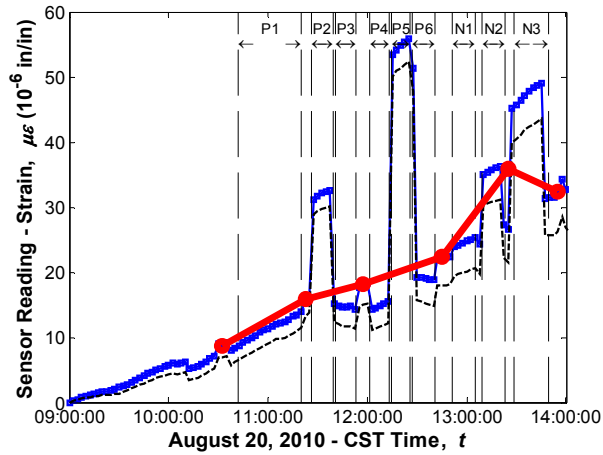
Sensor No. 68, Location G5S24, Midspan Top (Sisterbar)



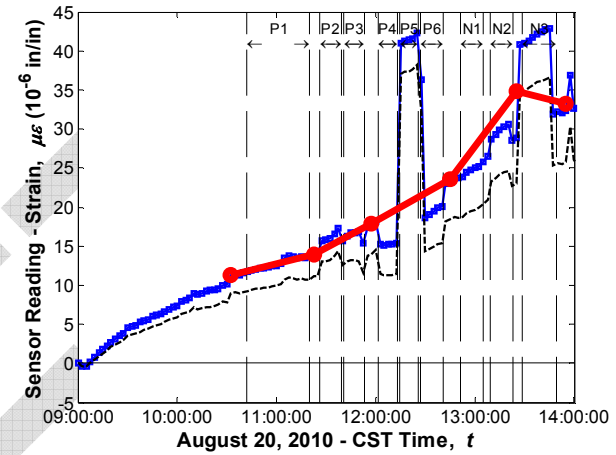
**Sensor No. 69, Location G5S24, Midspan Bottom
(Sisterbar)**



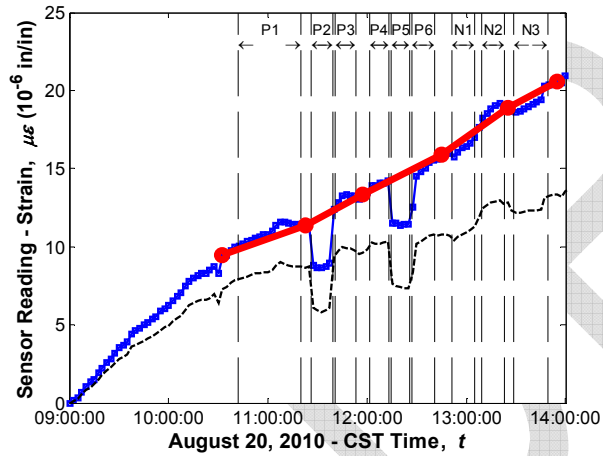
**Sensor No. 70, Location G5S24, Midspan Deck
(Sisterbar)**



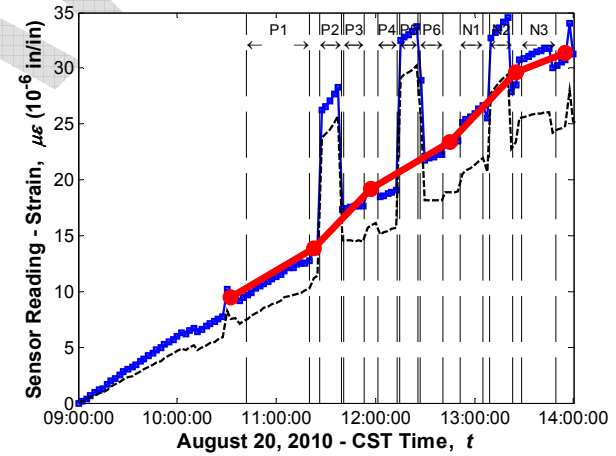
Sensor No. 71, Location Midspan (Vibrating wire gauge)



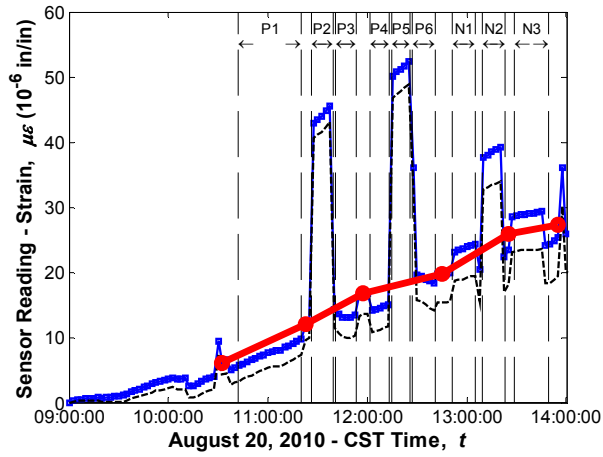
Sensor No. 72, Location Midspan (Vibrating wire gauge)



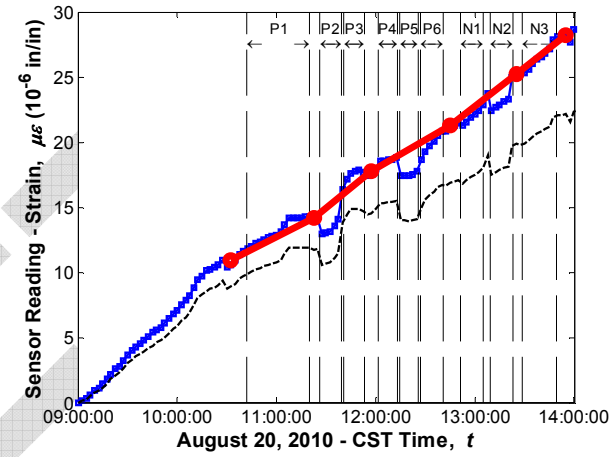
Sensor No. 81, Location G3S24, Midspan Top (Vibrating wire gauge)



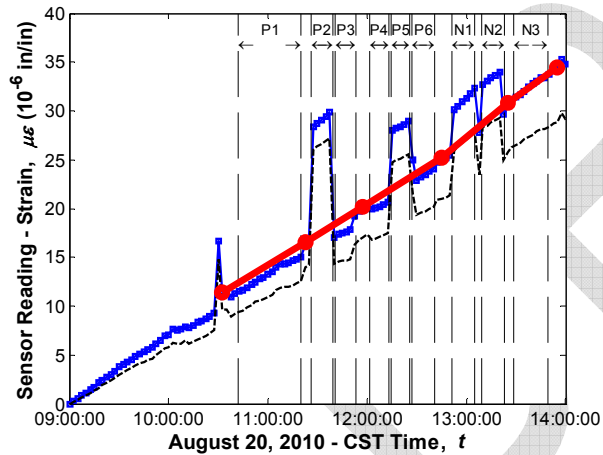
Sensor No. 82, Location G3S24, Midspan Middle (Vibrating wire gauge)



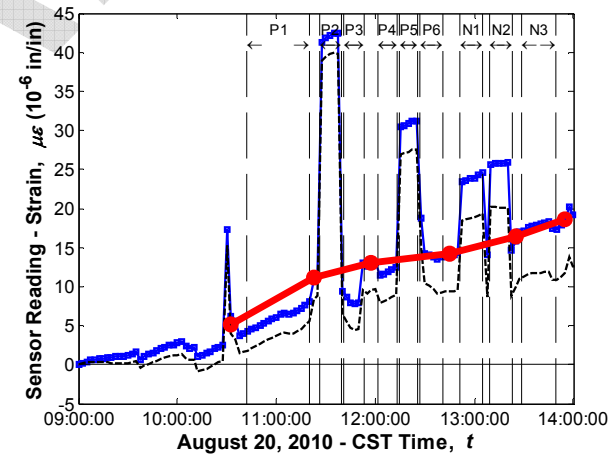
**Sensor No. 83, Location G3S24, Midspan Bottom
(Vibrating wire gauge)**



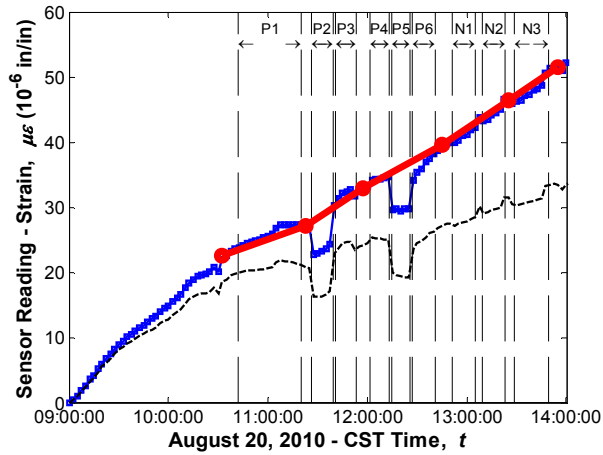
**Sensor No. 84, Location G4S24, Midspan Top (Vibrating
wire gauge)**



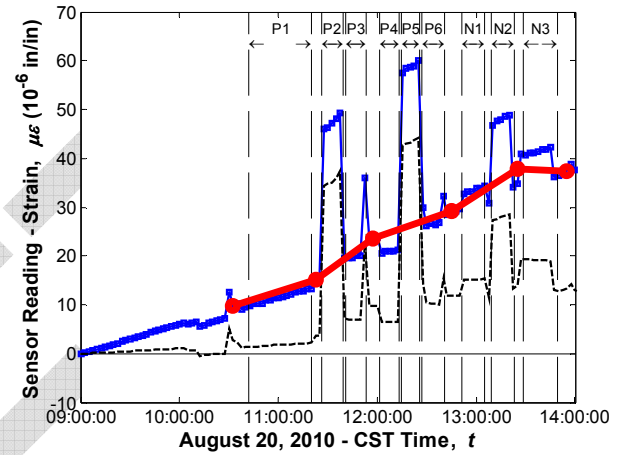
**Sensor No. 85, Location G4S24, Midspan Middle
(Vibrating wire gauge)**



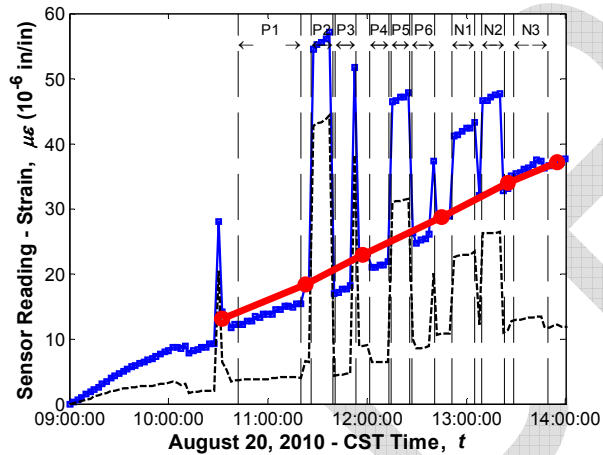
**Sensor No. 86, Location G4S24, Midspan Bottom
(Vibrating wire gauge)**



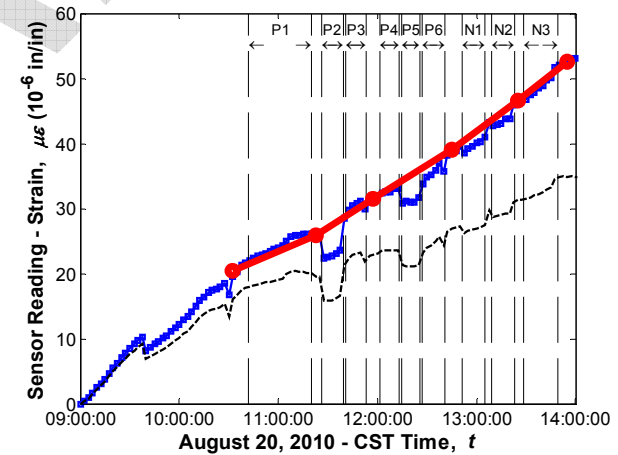
**Sensor No. 87, Location G4S24, Midspan Top
(Strandmeter)**



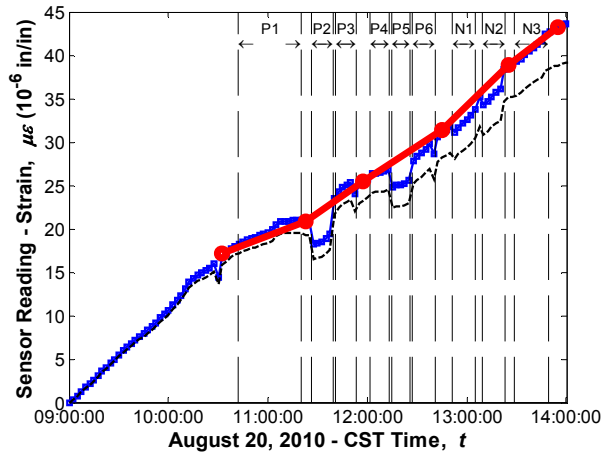
**Sensor No. 88, Location G4S24, Midspan Bottom
(Strandmeter)**



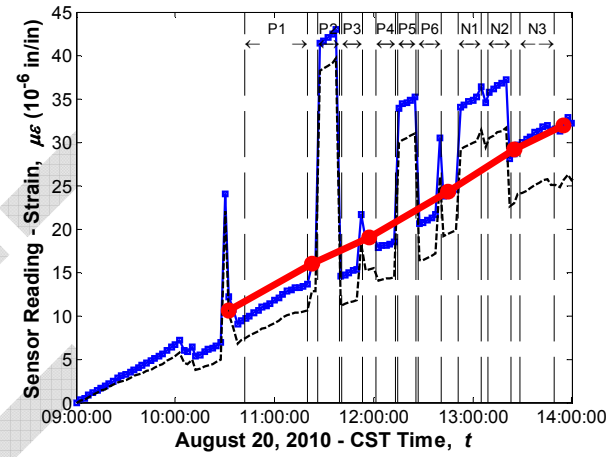
**Sensor No. 89, Location G3S24, Midspan Bottom
(Strandmeter)**



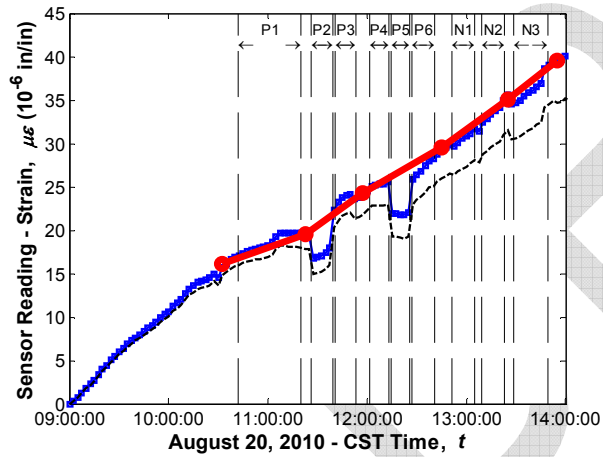
**Sensor No. 90, Location G3S24, Midspan Top
(Strandmeter)**



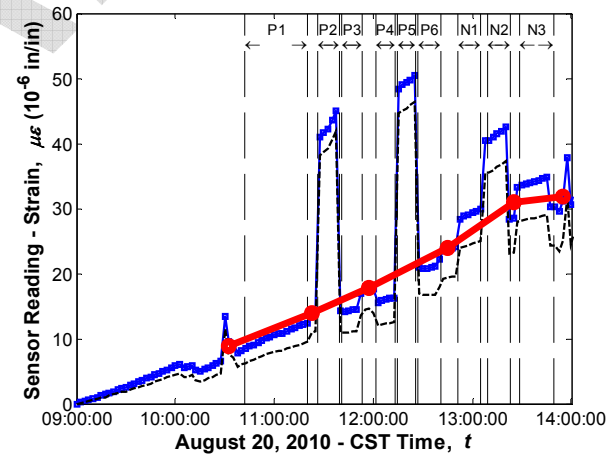
Sensor No. 91, Location G3S24, Midspan Top (Sisterbar)



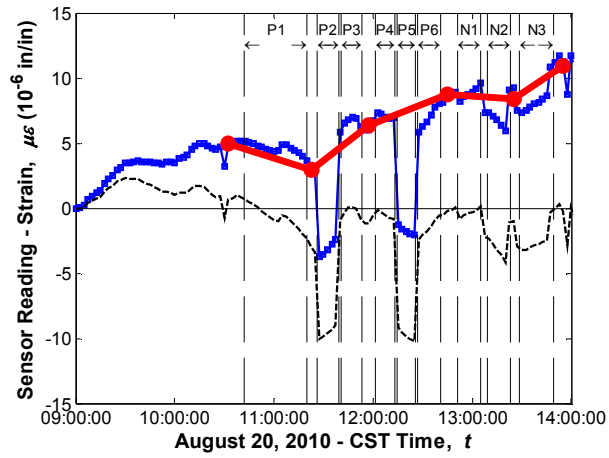
Sensor No. 92, Location G3S24, Midspan Bottom (Sisterbar)



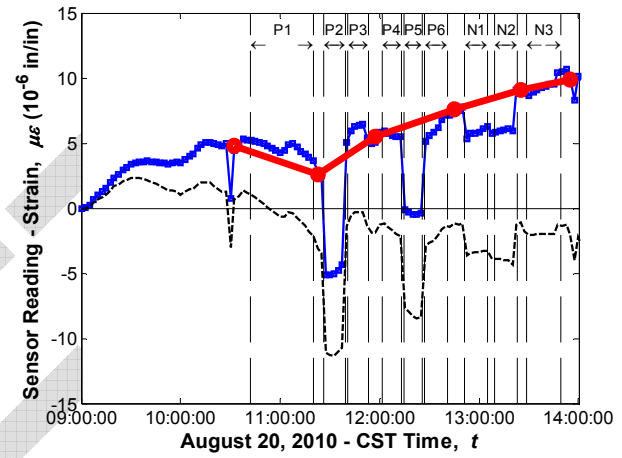
Sensor No. 93, Location G4S24, Midspan Top (Sisterbar)



Sensor No. 94, Location G4S24, Midspan Bottom (Sisterbar)



**Sensor No. 95, Location G3S24, Midspan Deck
(Sisterbar)**



**Sensor No. 96, Location G4S24, Midspan Deck
(Sisterbar)**

DRAFT

DRAFT

APPENDIX F

Element Types Used in Finite Element Analyses

This appendix describes the finite element types that were utilized in building the finite element models described in the “Finite Element Models” section of the report. Two categories of finite elements were used since ANSYS uses different elements for different physical environments. The first group of elements is used to perform thermal analyses, while the second group of elements was used to perform the stress analyses. A couple field analysis stores the results from the former (thermal analysis), which are then imposed of the model that performs the latter (stress analysis).

Elements used in thermal analyses

SOLID5: The SOLID5 is a 3 D eight node elements with up to six degrees of freedom in each node. The element has the thermal and structural field capability with limiting coupling. The geometry, node locations and the co-ordinate system of this element is shown in Fig. 5

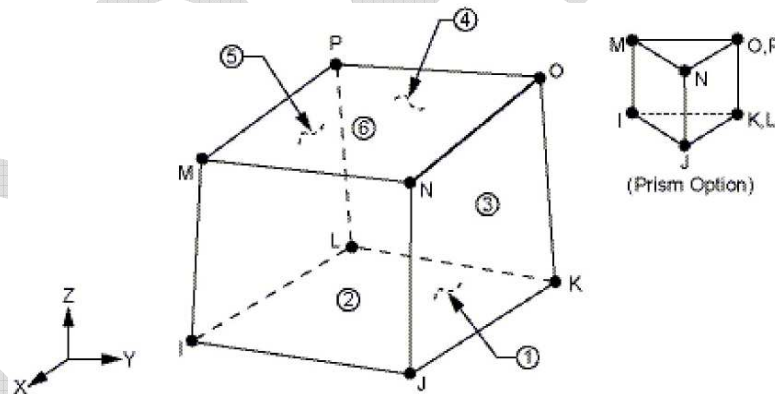


Figure E-1
Geometry, node and co-ordinate for SOLID5 element.

This element is used to model the concrete in thermal physics analysis. Temperature is applied at the selected nodes as a body force. ANSYS solves for the temperature and

provides the solution as temperature degrees of freedom at each node. This temperature is stored in the results file, which is then called at later stage to couple the analysis.

LINK68: The LINK68 is a 3-D uniaxial element with two degrees of freedom at each node. The element has capabilities to conduct heat and electrical current between its nodes. The geometry, node locations and co-ordinate systems for this element is shown in Figure E-2.

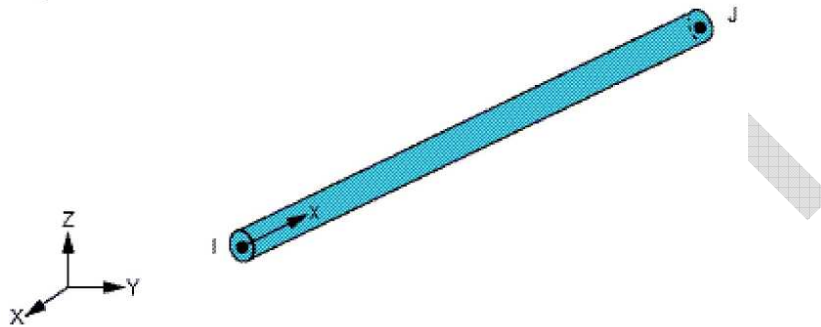


Figure E-2
Geometry, node location and co-ordinate system for LINK68.

This element is defined by two nodes, cross sectional area and the material properties. LINK68 was used to model the prestressing strands and the hairpin bar in the thermal physics analysis. The element solves for the temperature and gives solution as nodal temperature, which is stored as a results file for being used in the subsequent physics environment.

Elements used in stress analyses

SOLID65: The SOLID65 is a 3 D structural solid element especially designed for modeling concrete. This element has eight nodes with three translational degrees of freedom at each node. The element is capable of cracking in tension and crushing under compression. This element is used to model the concrete in structural physics environment. The most important features of this element are that, it can handle the nonlinear material properties. Thus it is capable to model cracking, crushing, plastic deformation and creep. The geometry, nodal locations and the co-ordinate system for this element is shown in Figure E-3.

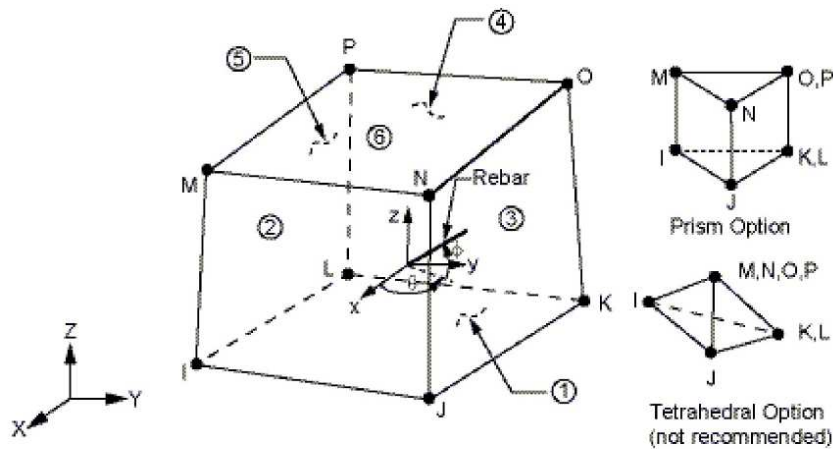


Figure E-3
Geometry, node location and co-ordinate system for SOLID65.

LINK8: LINK8 is a 3 D spar element used to model trusses, cables, links, springs etc. It has two nodes, and each node has three translational degrees of freedom. It is a uniaxial tension compression element thus no bending is considered. The element is defined by two nodes, cross sectional area and other material properties. This element is used to model the prestressing strands and hairpin bars in the structural physics environment. The prestressing is applied by incorporating the initial strain. The geometry, nodal locations and the co-ordinate system of this element is shown in Figure E-4.

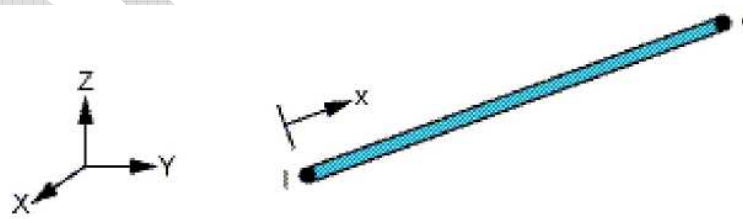


Figure E-4
Geometry, node location and co-ordinate system for LINK8.

SOLID45: SOLID45 is a 3-D structural solid used to model solid structures. This solids has 8-nodes with each node having three translational degrees of freedom in the x, y and z direction. This element has large deflection and large strain capabilities, for which it has been

used to model the bearing pads in these analysis. The bearing pad consists of alternate layer of steel and rubber, the rubber is used for energy dissipation and steel layer is being used for vertical stiffness. The equivalent stiffness properties are used as an input material parameter to model the bearing pads. The geometry, nodal locations and the co-ordinate system for this element is shown in Figure E-5.

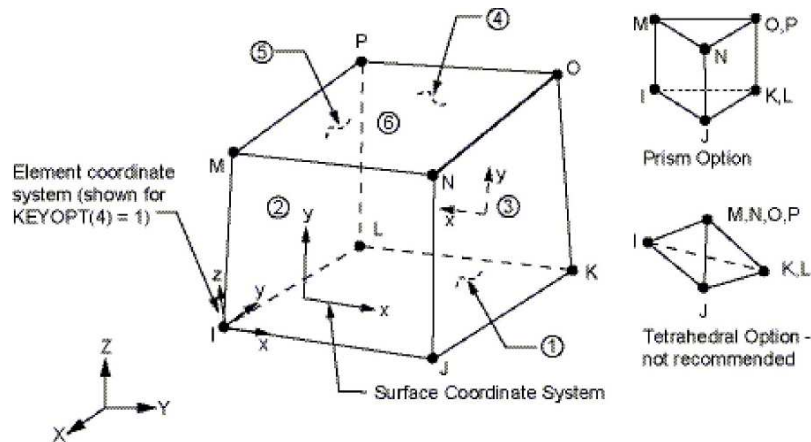


Figure E-5
Geometry, node location and co-ordinate system for SOLID45.

CONTA178: To model the contact and sliding between two nodes of any elements CONTA178 is used. This is a two node elements with three degrees of freedom at each node in the x, y and z directional translation. 2-D axisymmetric can also be modeled with this element by constraining the translation in the z direction. The element is capable of supporting compression in the contact normal direction and Coulomb friction in the tangential direction. The initial gap can also be modeled with this element. The geometry, nodal locations and the co-ordinate system for this element is shown in Figure E-6.

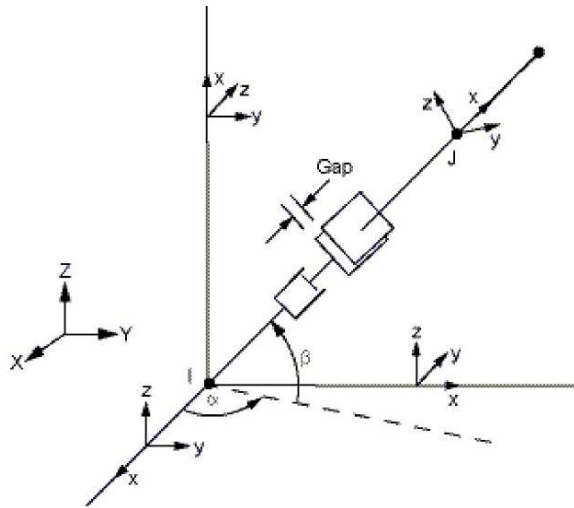


Figure E-6

Geometry, node location and co-ordinate system for CONTA178.

In order to define this element, two nodes, initial gap size or interference, initial element status and two damping coefficients needs to be defined. The orientation of the interface is defined by two ways: by the node locations or by the user defined normal direction. KEYOPT is used to define the contact algorithm. Coefficient of friction is used as the only material property for this element. The diaphragm is poured after placing the girder over the bents, therefore a cold joint developed between the girder and diaphragm interface. To model this contact CONTA178 element is used in this study.

APPENDIX G

Results for Parametric Study using mRESTRAINT

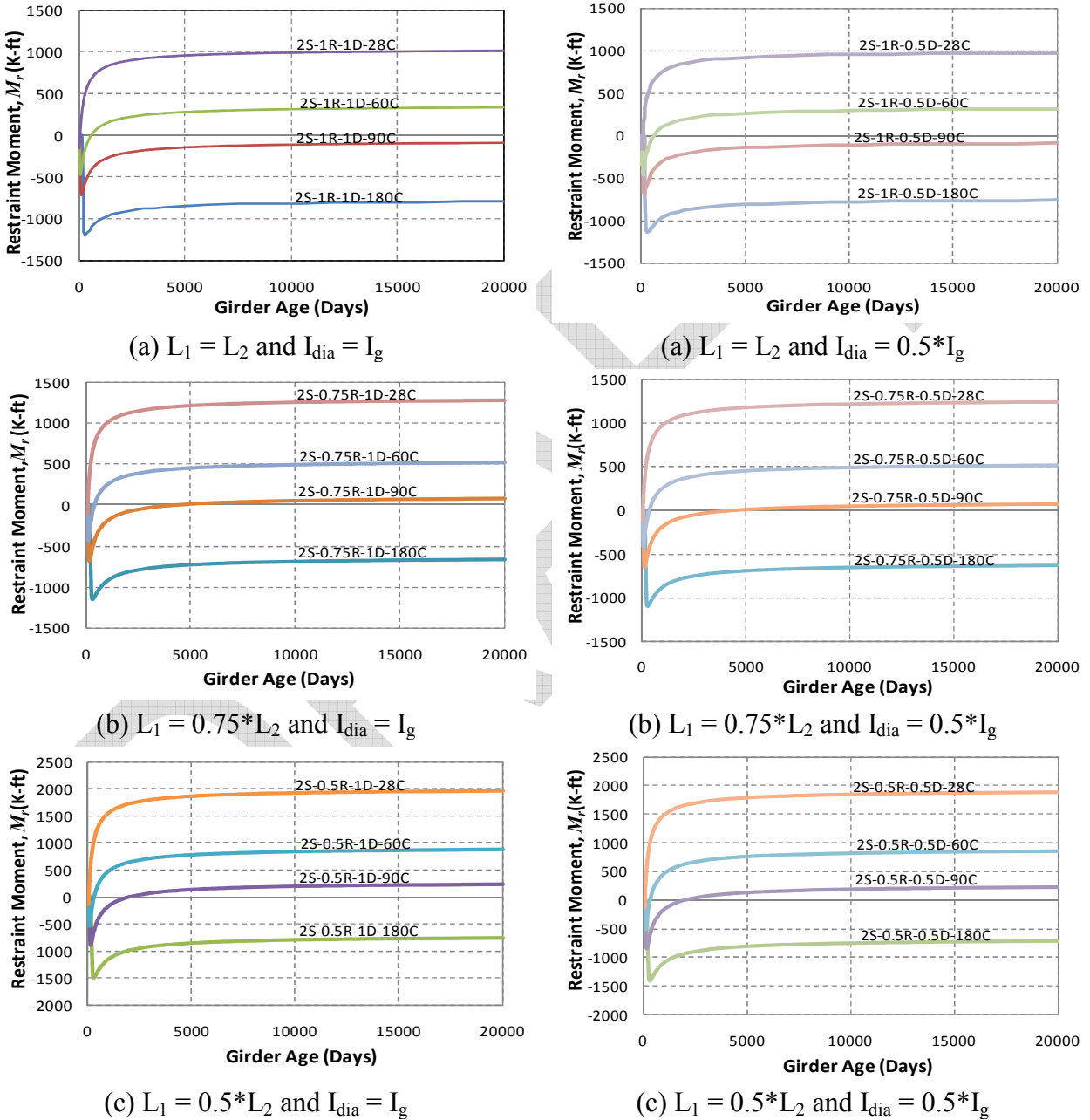
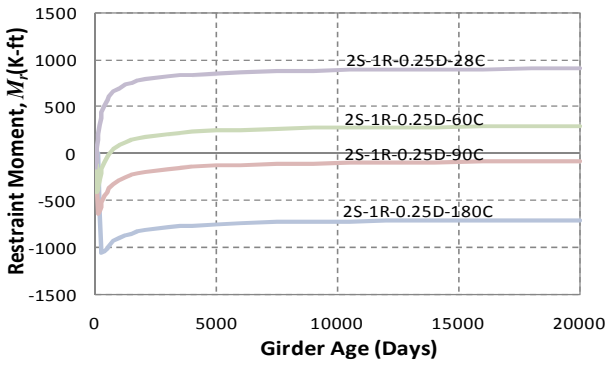
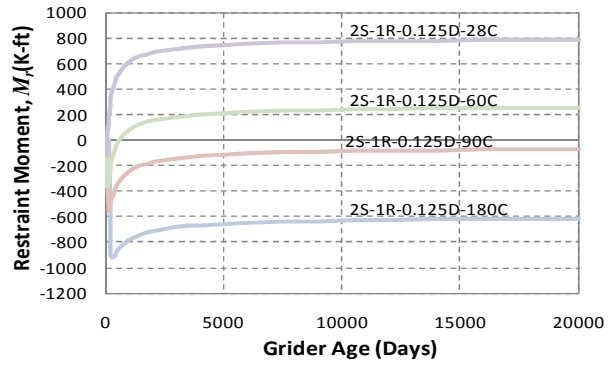


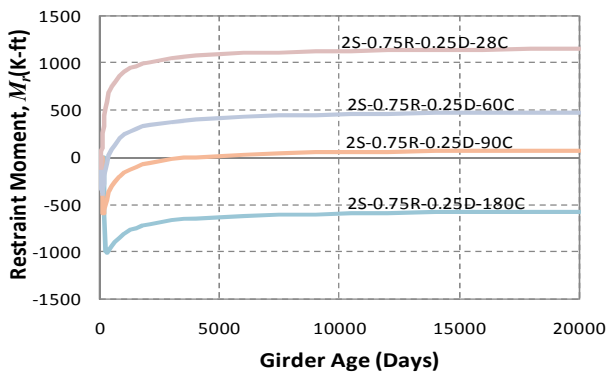
Fig. XX -



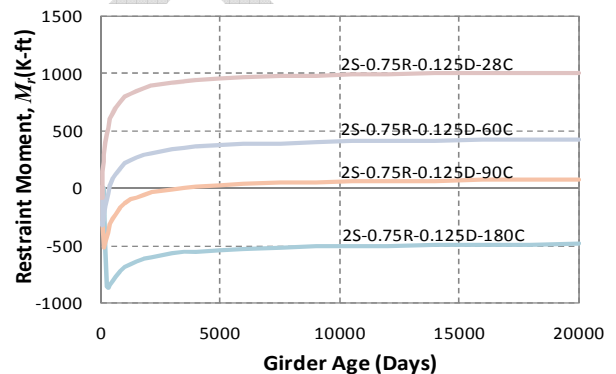
(a) $L_1 = L_2$ and $I_{dia} = 0.25 \cdot I_g$



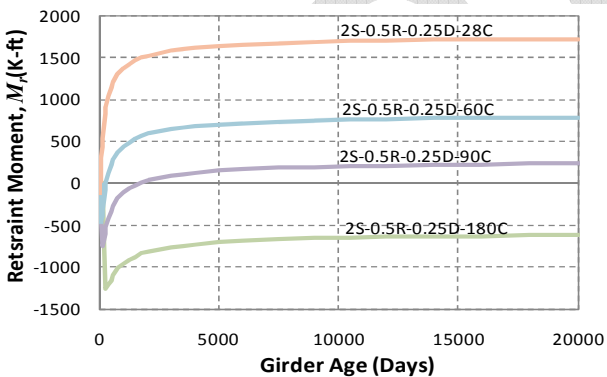
(a) $L_1 = L_2$ and $I_{dia} = 0.125 \cdot I_g$



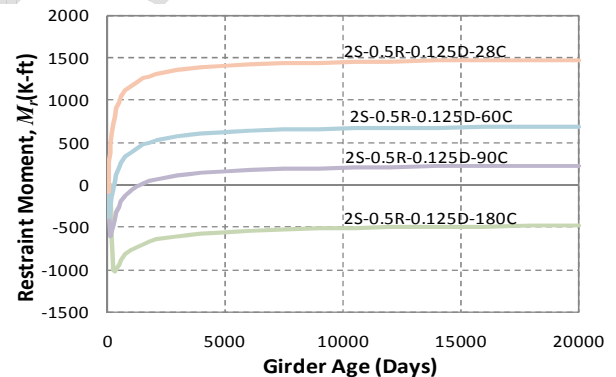
(b) $L_1 = 0.75 \cdot L_2$ and $I_{dia} = 0.25 \cdot I_g$



(b) $L_1 = 0.75 \cdot L_2$ and $I_{dia} = 0.125 \cdot I_g$

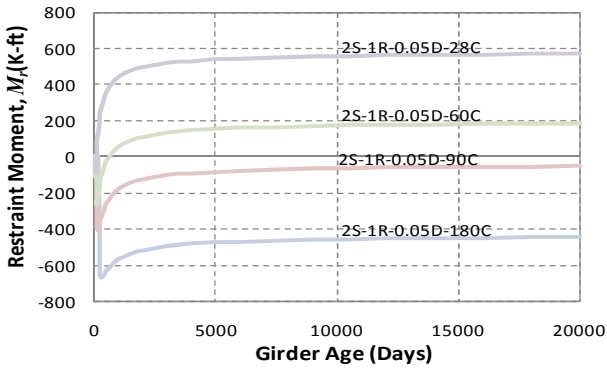


(c) $L_1 = 0.5 \cdot L_2$ and $I_{dia} = 0.25 \cdot I_g$

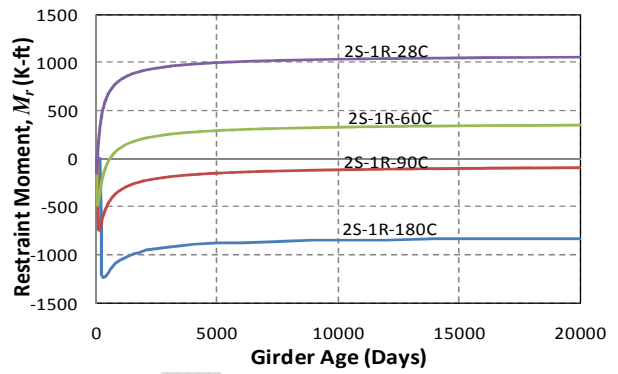


(c) $L_1 = 0.5 \cdot L_2$ and $I_{dia} = 0.125 \cdot I_g$

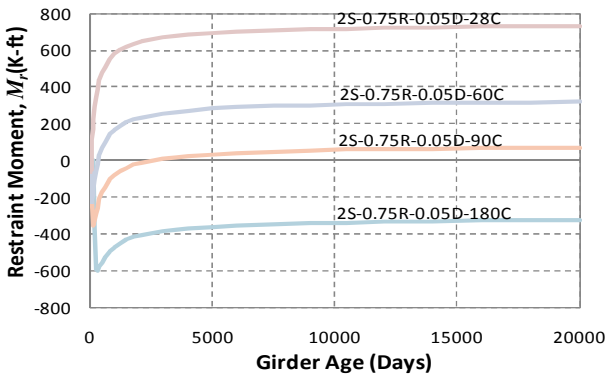
Fig. XX -



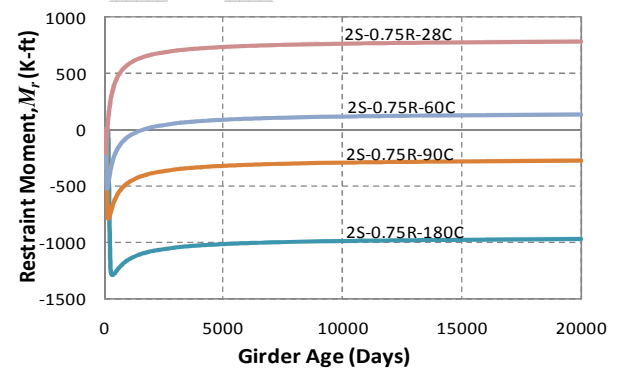
(a) $L_1 = L_2$ and $I_{dia} = 0.05 * I_g$



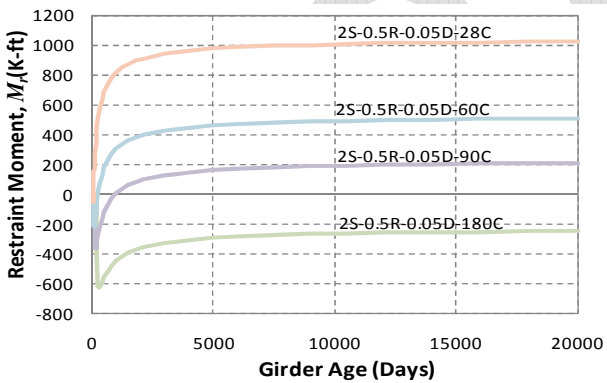
(a) $L_1 = L_2$ and $I_{dia} = 0$



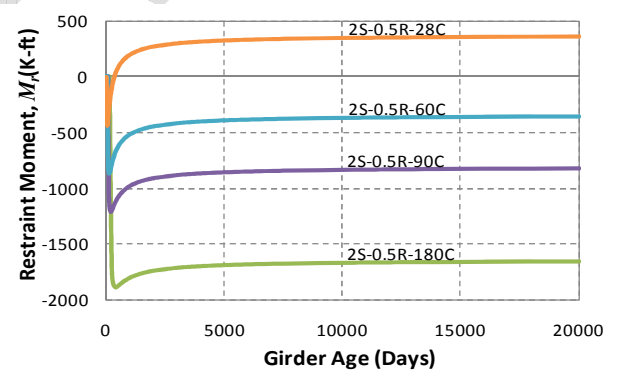
(b) $L_1 = 0.75 * L_2$ and $I_{dia} = 0.05 * I_g$



(b) $L_1 = 0.75 * L_2$ and $I_{dia} = 0$

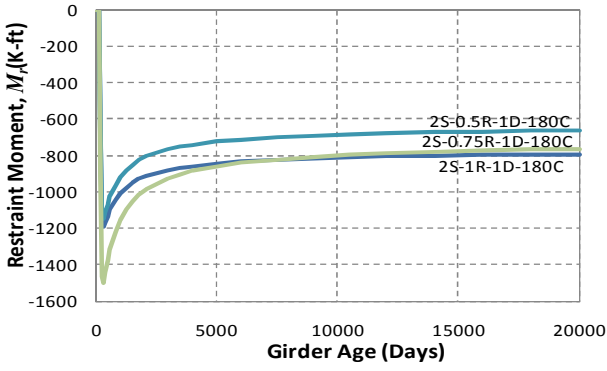


(c) $L_1 = 0.5 * L_2$ and $I_{dia} = 0.05 * I_g$

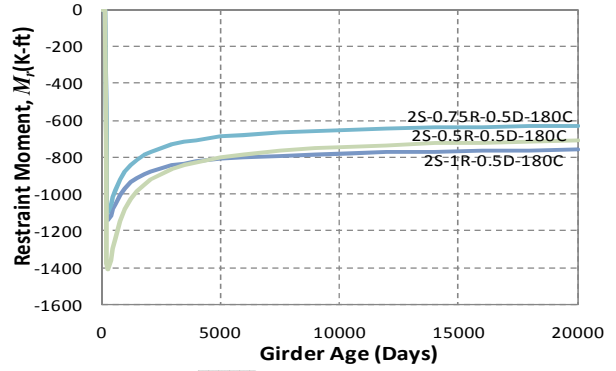


(c) $L_1 = 0.5 * L_2$ and $I_{dia} = 0$

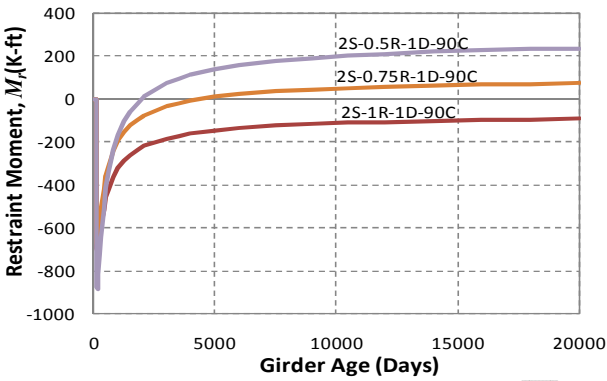
Fig. XX -



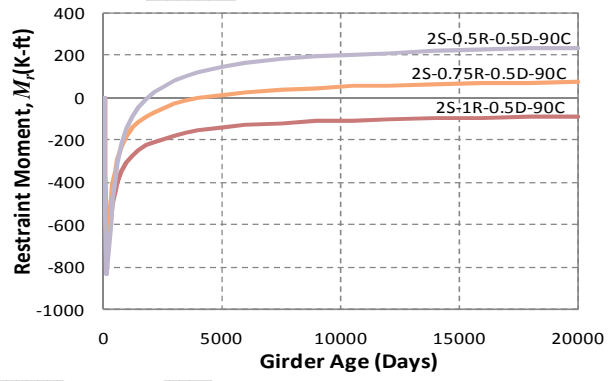
(a) Age = 180 days and $I_{dia} = I_g$



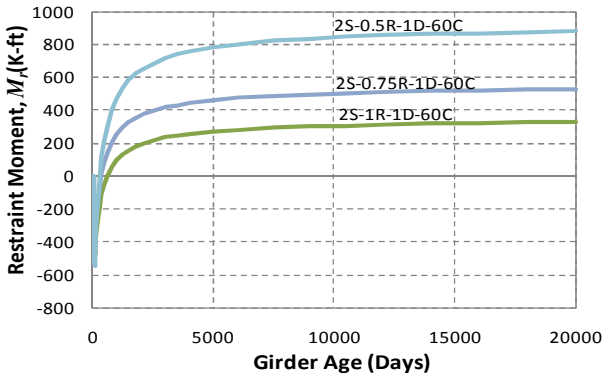
(a) Age = 180 days and $I_{dia} = 0.5 * I_g$



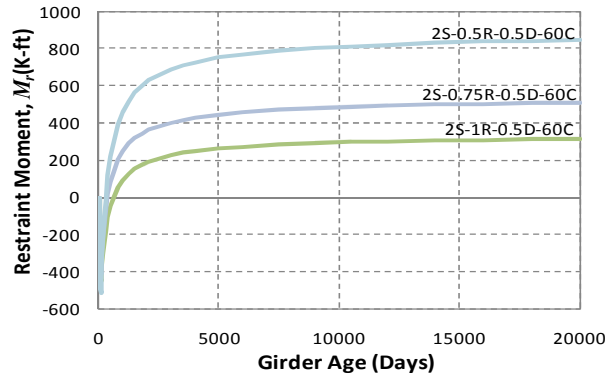
(b) Age = 90 days and $I_{dia} = I_g$



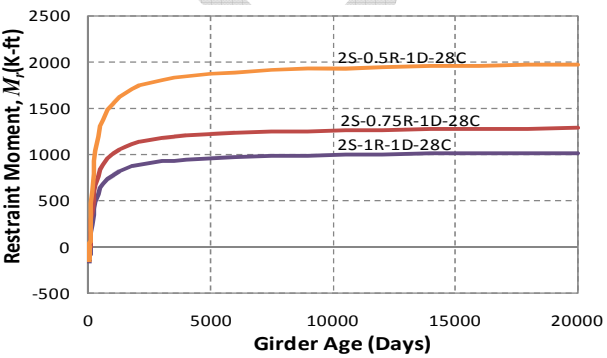
(b) Age = 90 days and $I_{dia} = 0.5 * I_g$



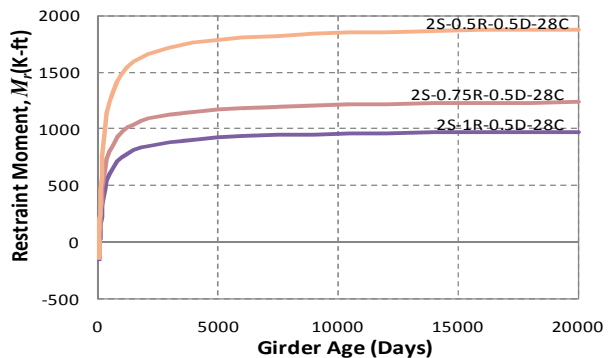
(c) Age = 60 days and $I_{dia} = I_g$



(c) Age = 60 days and $I_{dia} = 0.5 * I_g$



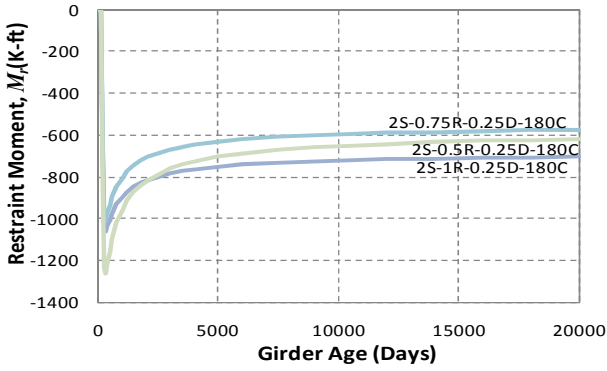
(d) Age = 28 days and $I_{dia} = I_g$



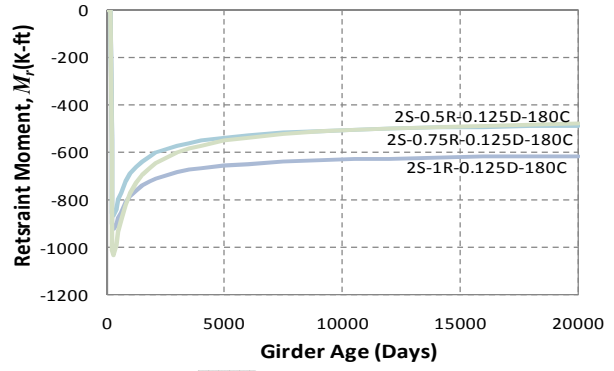
(d) Age = 28 days and $I_{dia} = 0.5 * I_g$

Fig. XX -

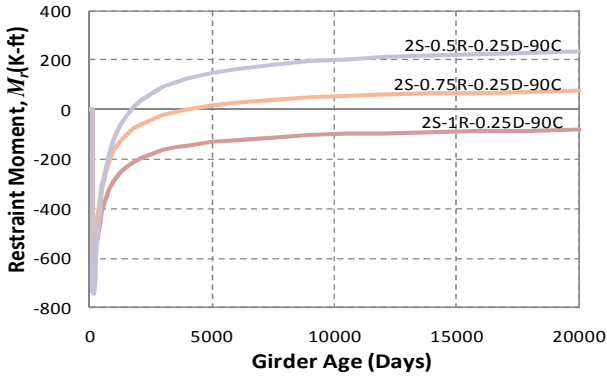
DRAFT



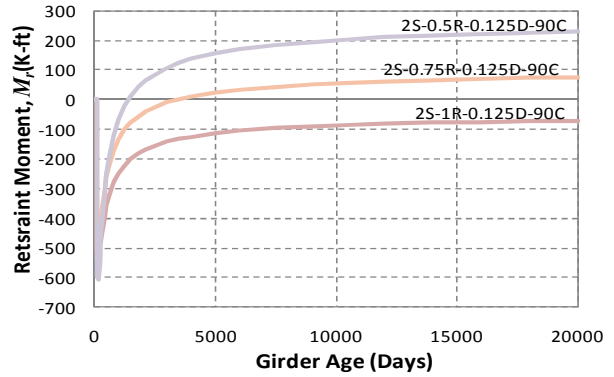
(a) Age = 180 days and $I_{dia} = 0.25 \cdot I_g$



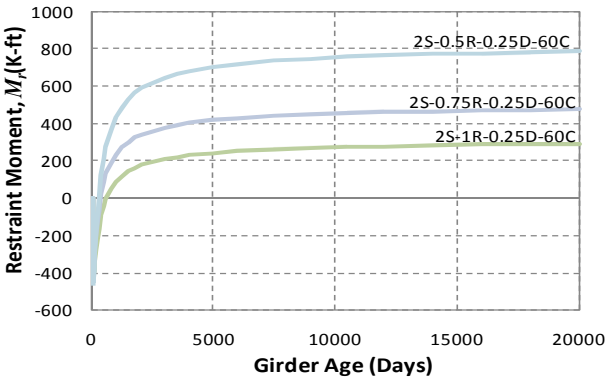
(a) Age = 180 days and $I_{dia} = 0.125 \cdot I_g$



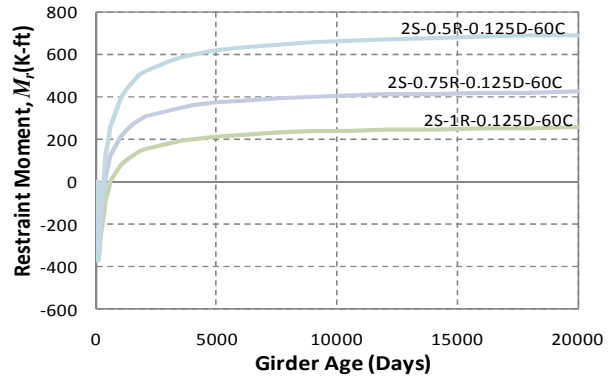
(b) Age = 90 days and $I_{dia} = 0.25 \cdot I_g$



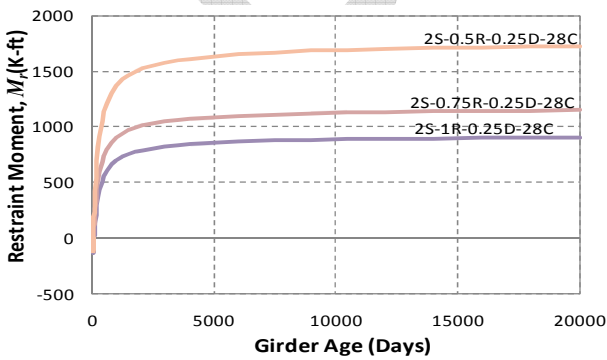
(b) Age = 90 days and $I_{dia} = 0.125 \cdot I_g$



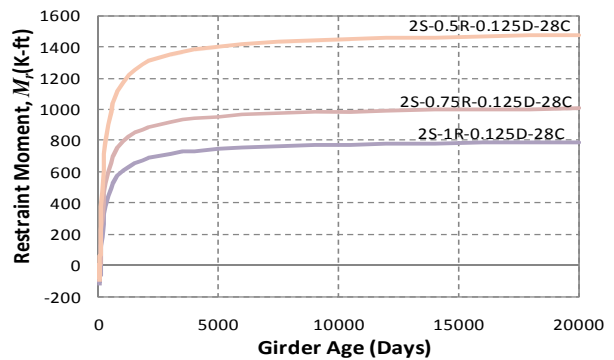
(c) Age = 60 days and $I_{dia} = 0.25 \cdot I_g$



(c) Age = 60 days and $I_{dia} = 0.125 \cdot I_g$



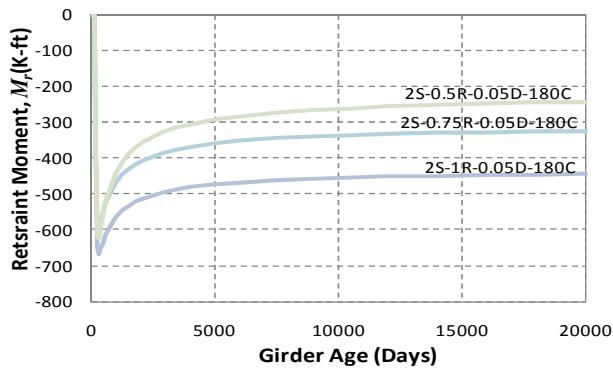
(d) Age = 28 days and $I_{dia} = 0.25 \cdot I_g$



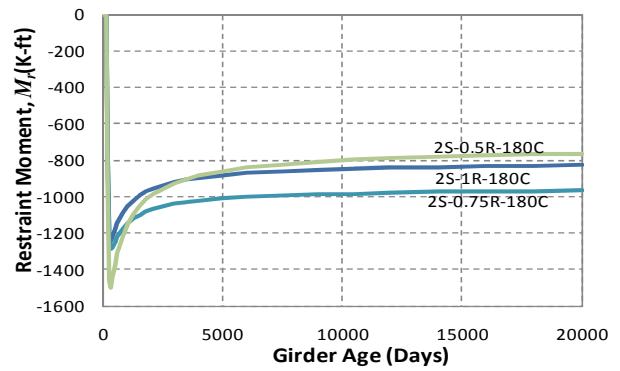
(d) Age = 28 days and $I_{dia} = 0.125 \cdot I_g$

Fig. XX -

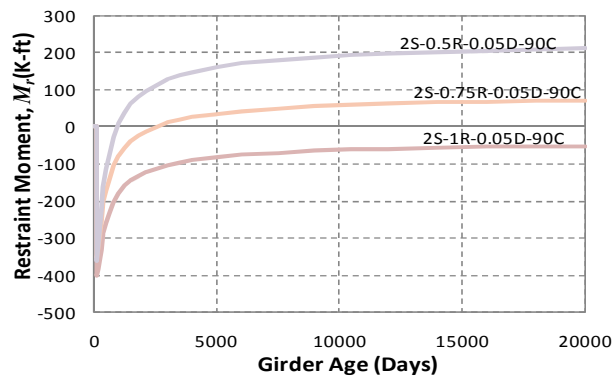
DRAFT



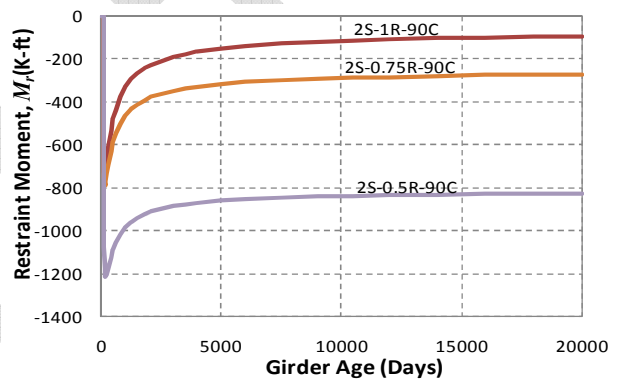
(a) Age = 180 days and $I_{dia} = 0.05I_g$



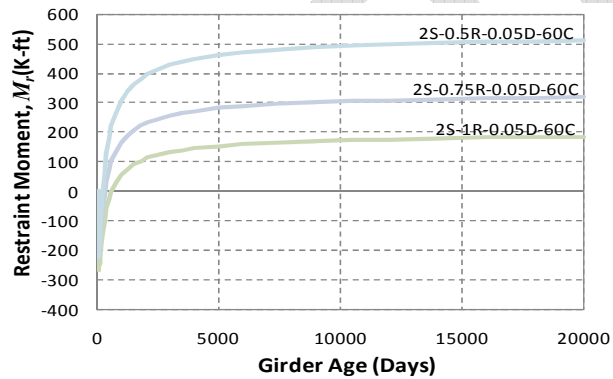
(a) Age = 180 days and $I_{dia} = 0$



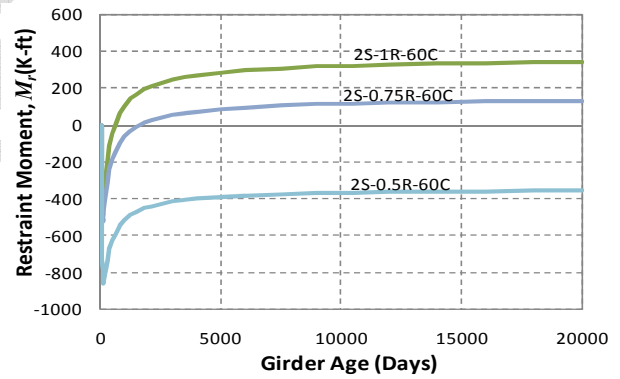
(b) Age = 90 days and $I_{dia} = 0.05I_g$



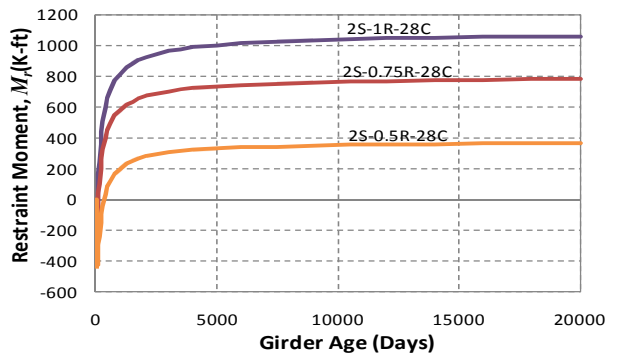
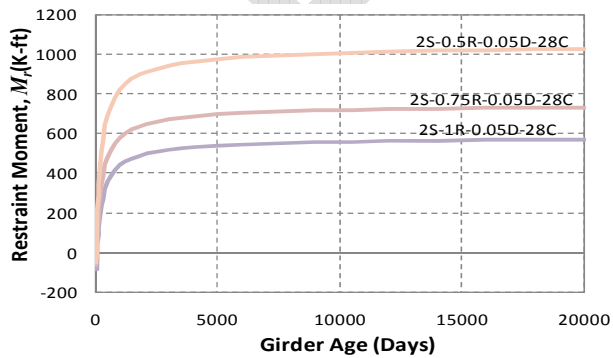
(b) Age = 90 days and $I_{dia} = 0$



(c) Age = 60 days and $I_{dia} = 0.05I_g$



(c) Age = 60 days and $I_{dia} = 0$

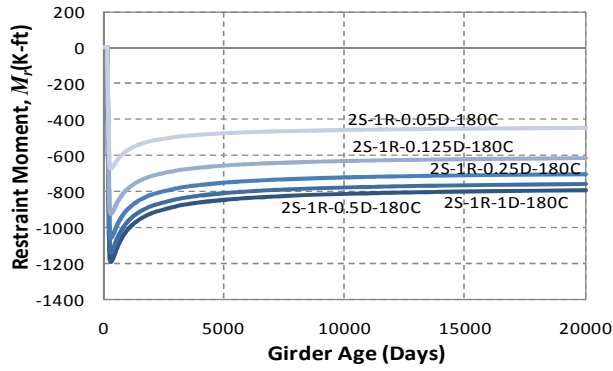


(d) Age = 28 days and $I_{dia} = 0.05I_g$

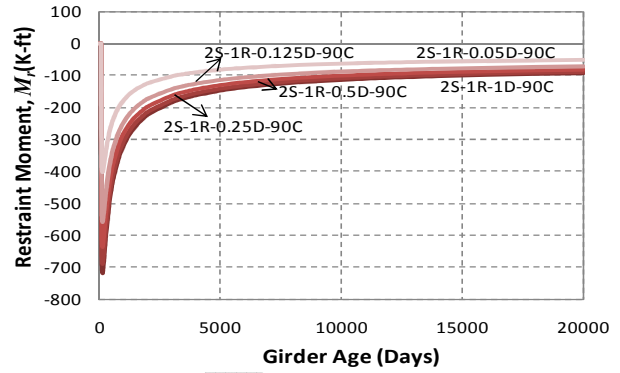
(d) Age = 28 days and $I_{dia} = 0$

Fig. XX -

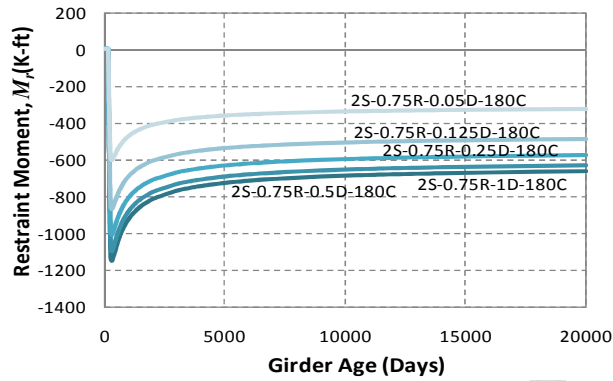
DRAFT



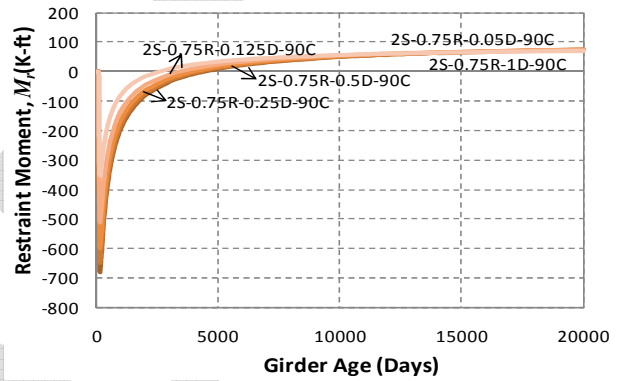
(a) $L_1 = L_2$ and Age = 180 days



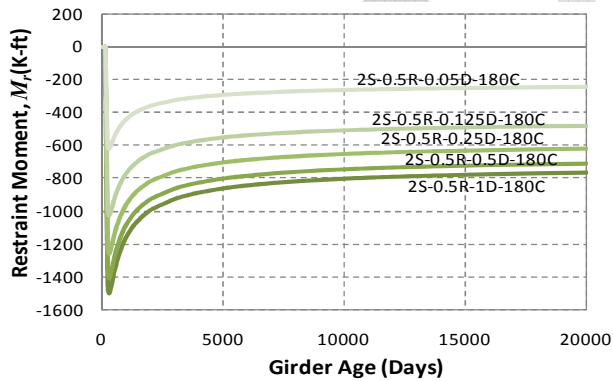
(a) $L_1 = L_2$ and Age = 90 days



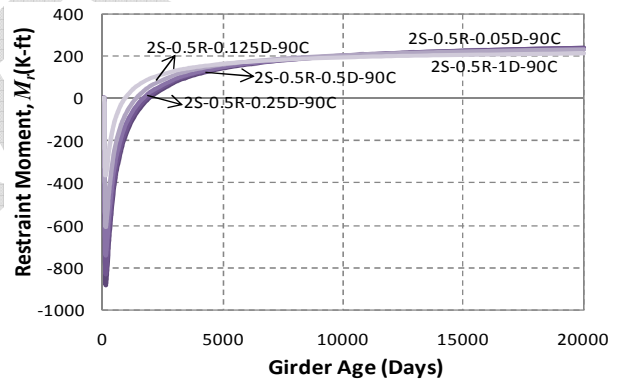
(b) $L_1 = 0.75 * L_2$ and Age = 180 days



(b) $L_1 = 0.75 * L_2$ and Age = 90 days

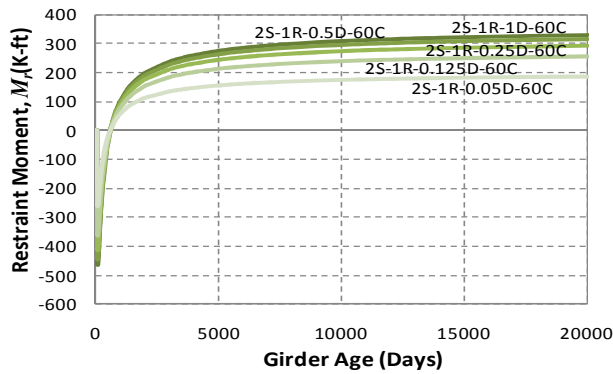


(c) $L_1 = 0.5 * L_2$ and Age = 180 days

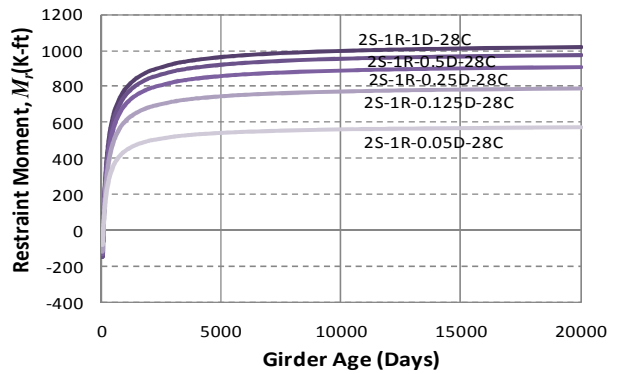


(c) $L_1 = 0.5 * L_2$ and Age = 90 days

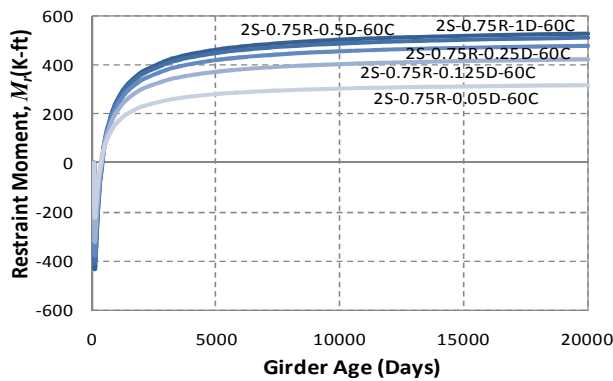
Fig. XX -



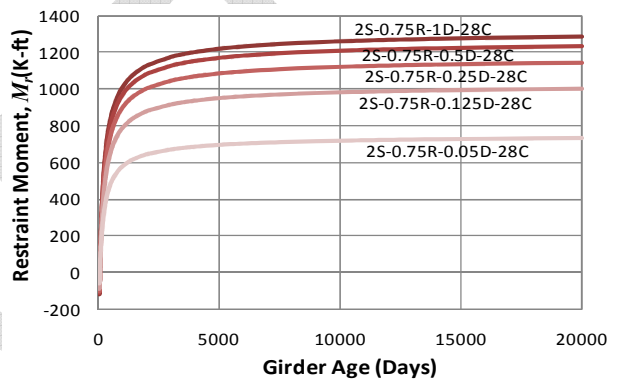
(a) $L_1 = L_2$ and Age = 60 days



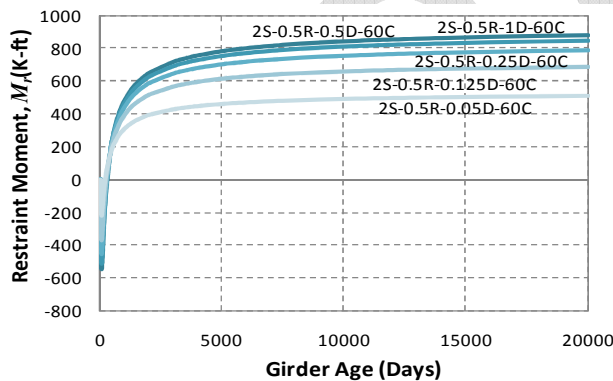
(a) $L_1 = L_2$ and Age = 28 days



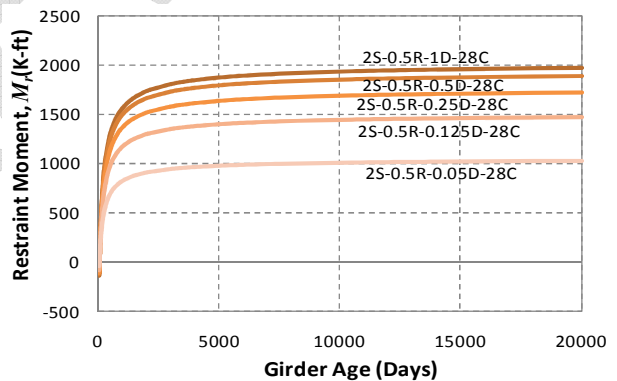
(b) $L_1 = 0.75 \cdot L_2$ and Age = 60 days



(b) $L_1 = 0.75 \cdot L_2$ and Age = 28 days

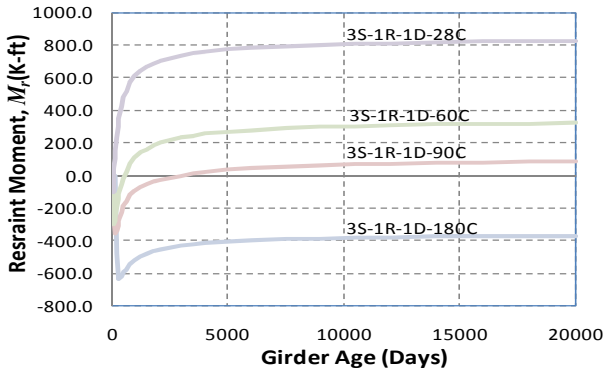


(c) $L_1 = 0.5 \cdot L_2$ and Age = 60 days

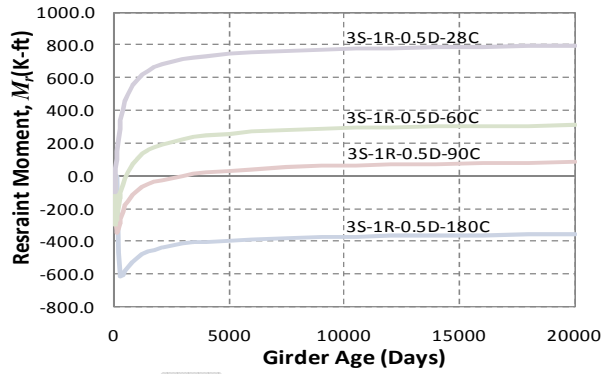


(c) $L_1 = 0.5 \cdot L_2$ and Age = 28 days

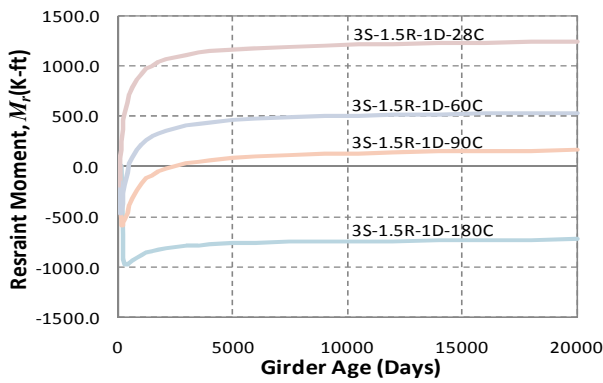
Fig. XX -



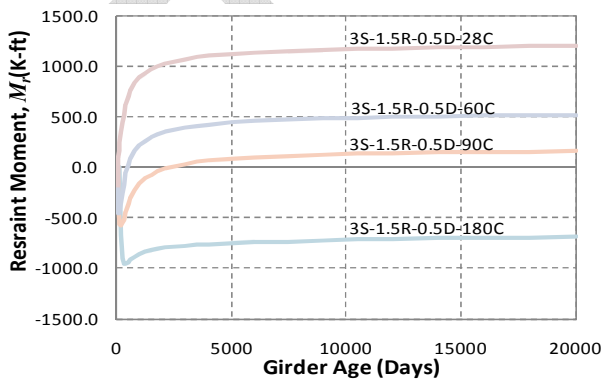
(a) $L_1 = L_2 = L_3$ and $I_{dia} = I_g$



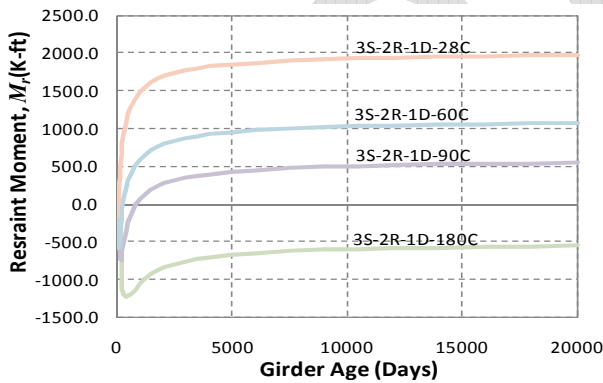
(a) $L_1 = L_2 = L_3$ and $I_{dia} = 0.5 * I_g$



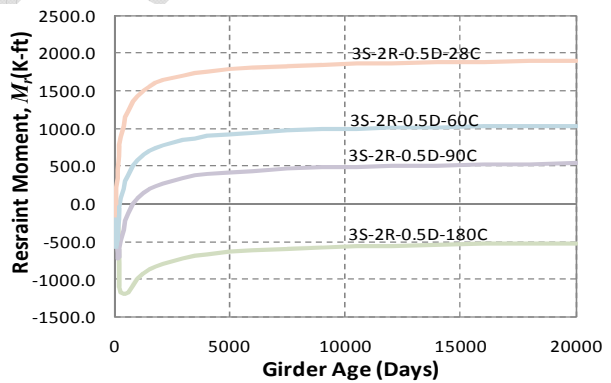
(b) $L_2 = 1.5 * L_1 = 1.5 * L_3$ and $I_{dia} = I_g$



(b) $L_2 = 1.5 * L_1 = 1.5 * L_3$ and $I_{dia} = 0.5 * I_g$

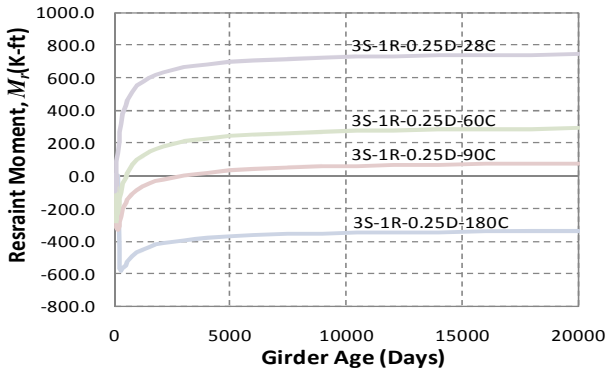


(c) $L_2 = 2 * L_1 = 2 * L_3$ and $I_{dia} = I_g$

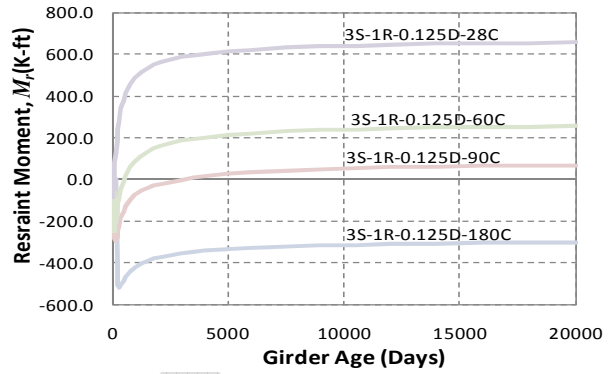


(c) $L_2 = 2 * L_1 = 2 * L_3$ and $I_{dia} = 0.5 * I_g$

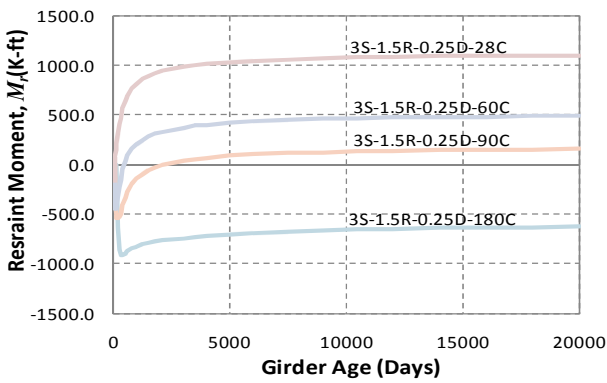
Fig. XX -



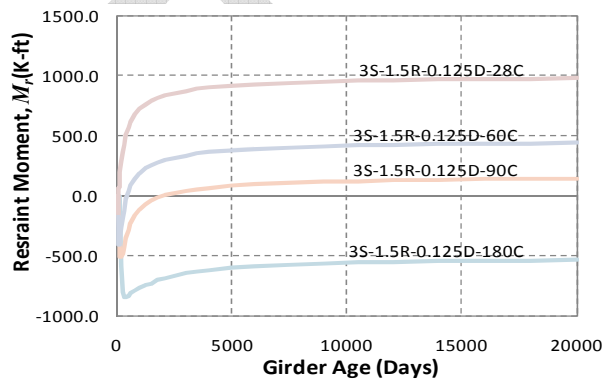
(a) $L_1 = L_2 = L_3$ and $I_{dia} = 0.25 * I_g$



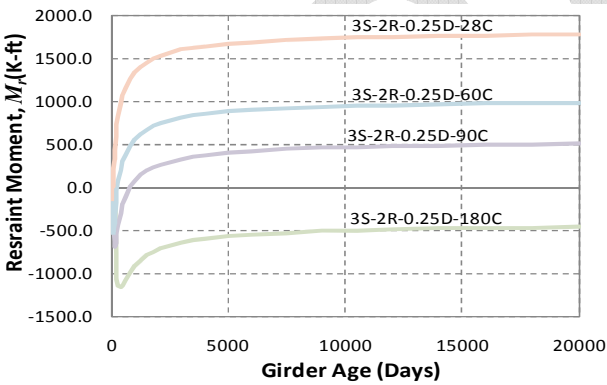
(a) $L_1 = L_2 = L_3$ and $I_{dia} = 0.125 * I_g$



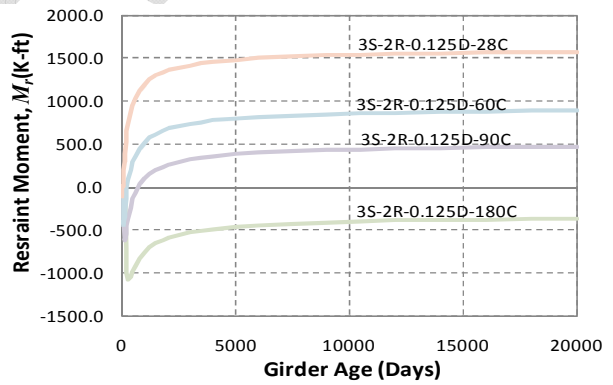
(b) $L_2 = 1.5 * L_1 = 1.5 * L_3$ and $I_{dia} = 0.25 * I_g$



(b) $L_2 = 1.5 * L_1 = 1.5 * L_3$ and $I_{dia} = 0.125 * I_g$

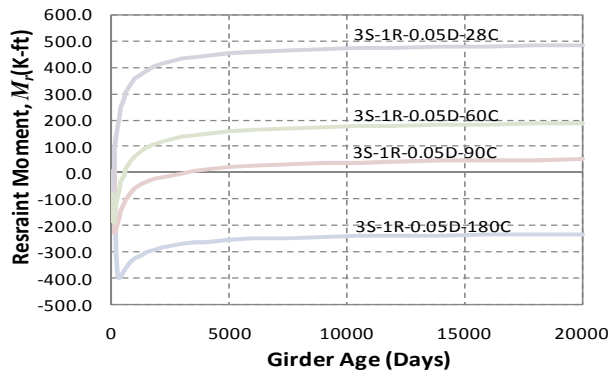


(c) $L_2 = 2 * L_1 = 2 * L_3$ and $I_{dia} = 0.25 * I_g$

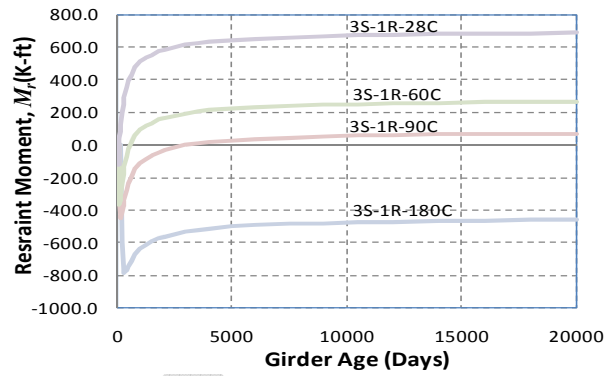


(c) $L_2 = 2 * L_1 = 2 * L_3$ and $I_{dia} = 0.125 * I_g$

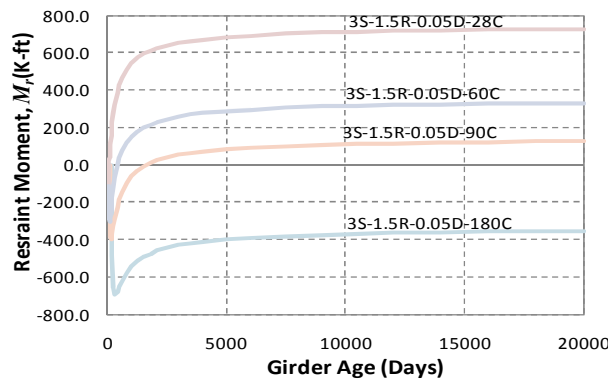
Fig. XX -



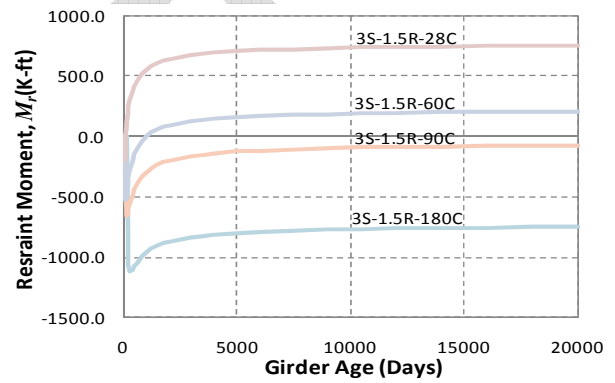
(a) $L_1 = L_2 = L_3$ and $I_{dia} = 0.05 * I_g$



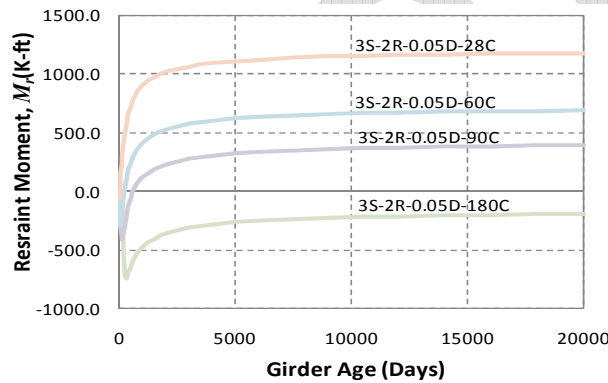
(a) $L_1 = L_2 = L_3$ and $I_{dia} = 0$



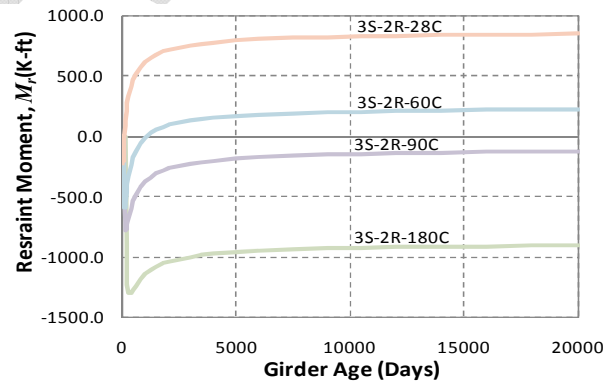
(b) $L_2 = 1.5 * L_1 = 1.5 * L_3$ and $I_{dia} = 0.05 * I_g$



(b) $L_2 = 1.5 * L_1 = 1.5 * L_3$ and $I_{dia} = 0$

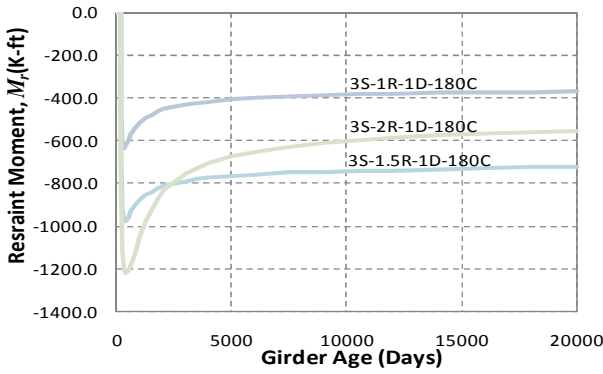


(c) $L_2 = 2 * L_1 = 2 * L_3$ and $I_{dia} = 0.05 * I_g$

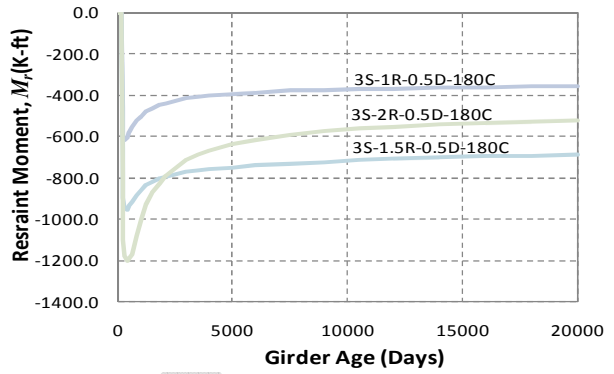


(c) $L_2 = 2 * L_1 = 2 * L_3$ and $I_{dia} = 0$

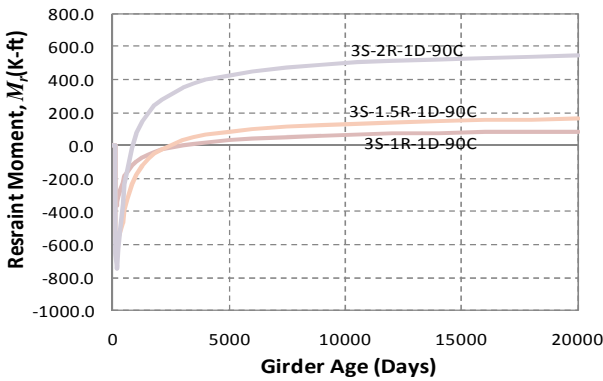
Fig. XX -



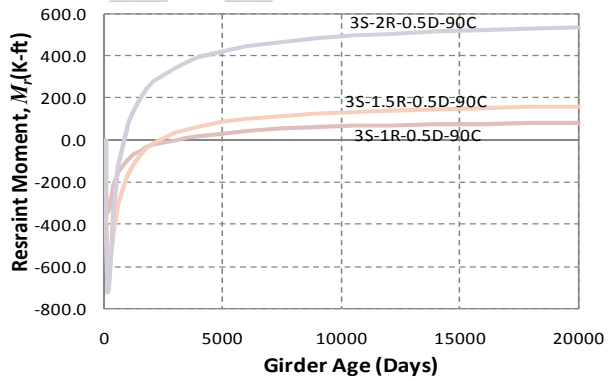
(a) Age = 180 days and $I_{dia} = I_g$



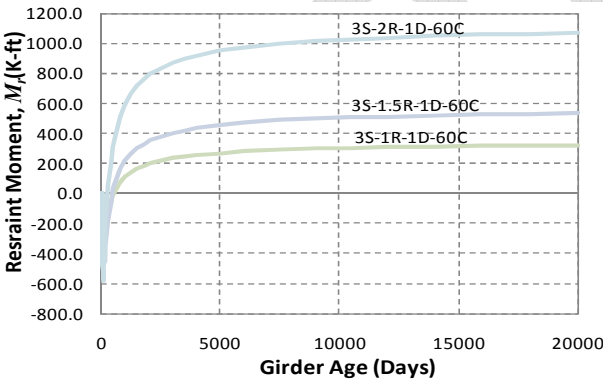
(a) Age = 180 days and $I_{dia} = 0.5 * I_g$



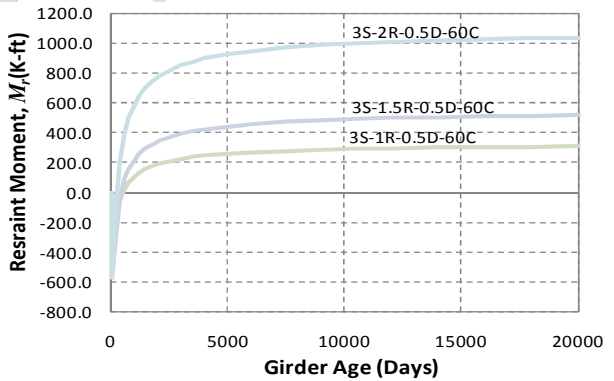
(b) Age = 90 days and $I_{dia} = I_g$



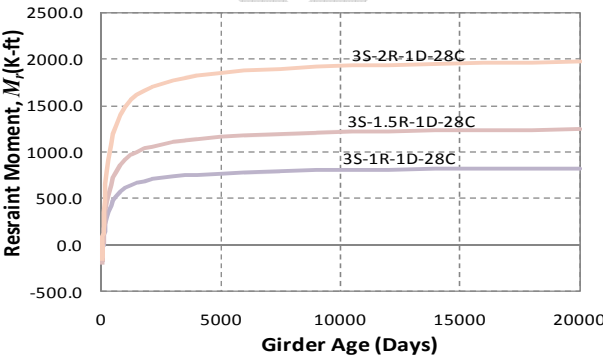
(b) Age = 90 days and $I_{dia} = 0.5 * I_g$



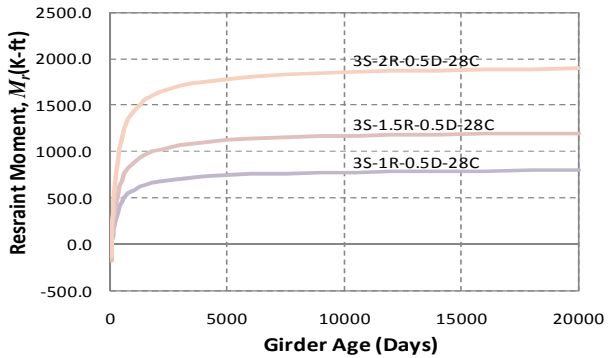
(c) Age = 60 days and $I_{dia} = I_g$



(c) Age = 60 days and $I_{dia} = 0.5 * I_g$



(c) Age = 60 days and $I_{dia} = I_g$



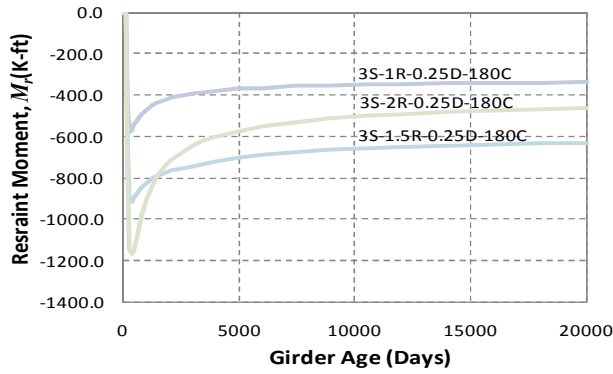
(c) Age = 60 days and $I_{dia} = 0.5 * I_g$

(d) Age = 28 days and $I_{dia} = I_g$

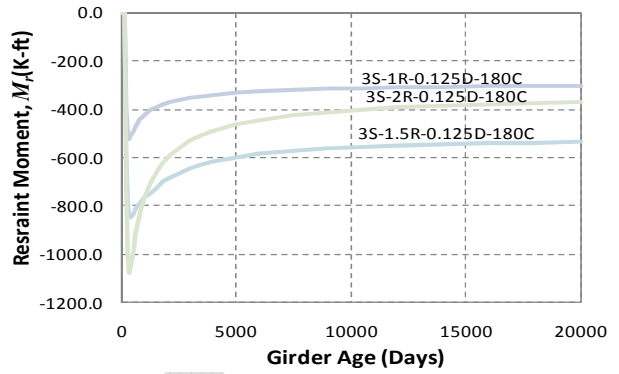
(d) Age = 28 days and $I_{dia} = 0.5 \cdot I_g$

Fig. XX -

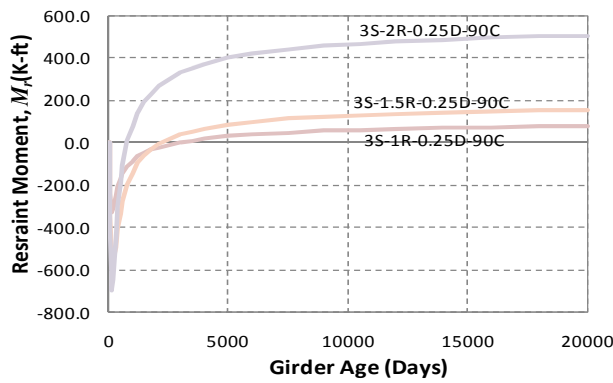
DRAFT



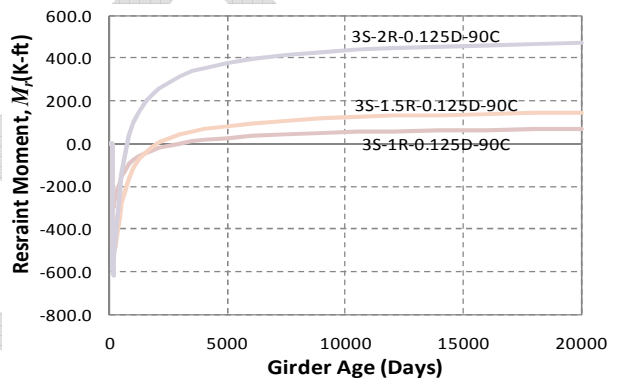
(a) Age = 180 days and $I_{dia} = 0.25 \cdot I_g$



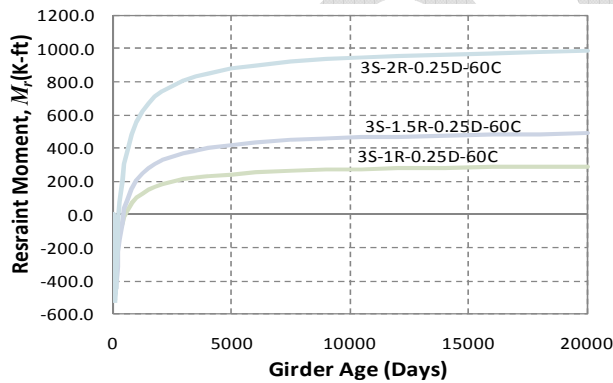
(a) Age = 180 days and $I_{dia} = 0.125 \cdot I_g$



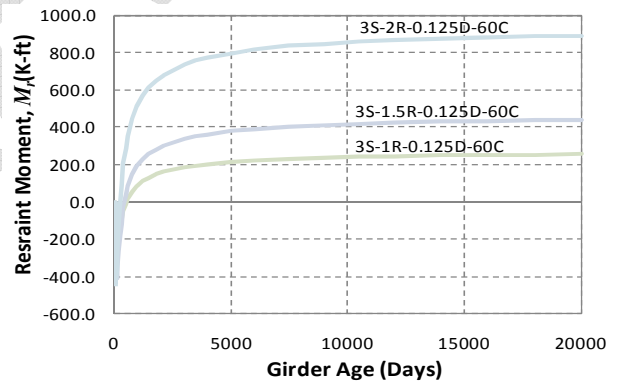
(b) Age = 90 days and $I_{dia} = 0.25 \cdot I_g$



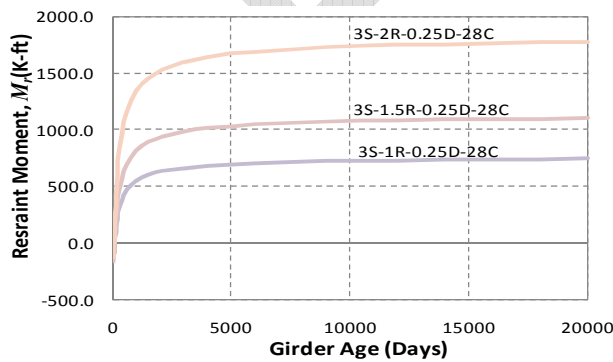
(b) Age = 90 days and $I_{dia} = 0.125 \cdot I_g$



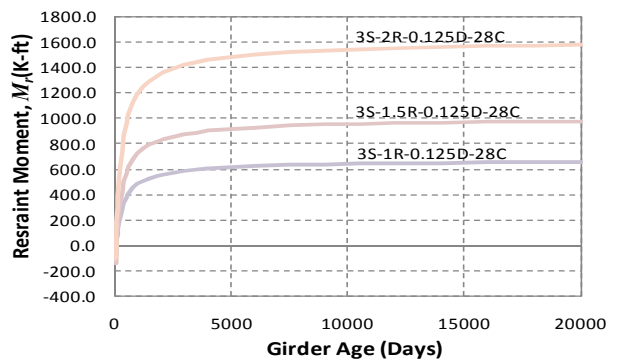
(c) Age = 60 days and $I_{dia} = 0.25 \cdot I_g$



(c) Age = 60 days and $I_{dia} = 0.125 \cdot I_g$



(c) Age = 60 days and $I_{dia} = 0.25 \cdot I_g$



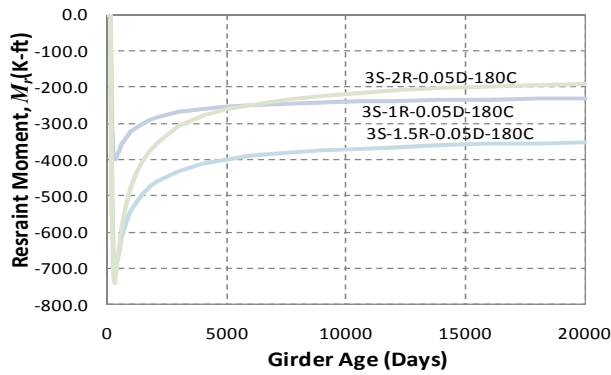
(c) Age = 60 days and $I_{dia} = 0.125 \cdot I_g$

(d) Age = 28 days and $I_{\text{dia}} = 0.25 \cdot I_g$

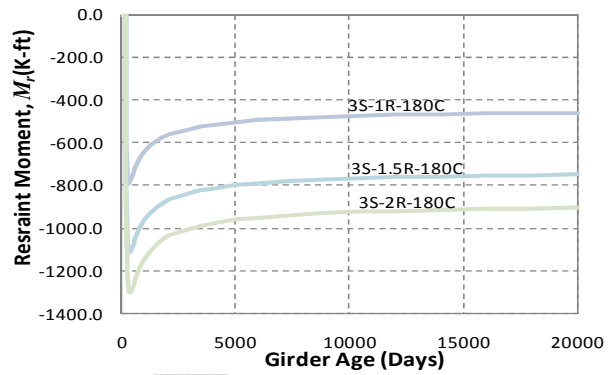
(d) Age = 28 days and $I_{\text{dia}} = 0.125 \cdot I_g$

Fig. XX -

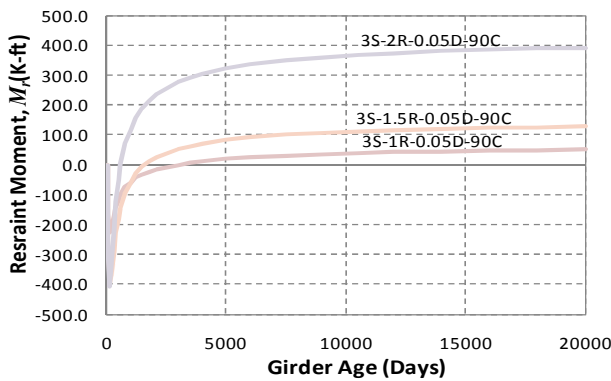
DRAFT



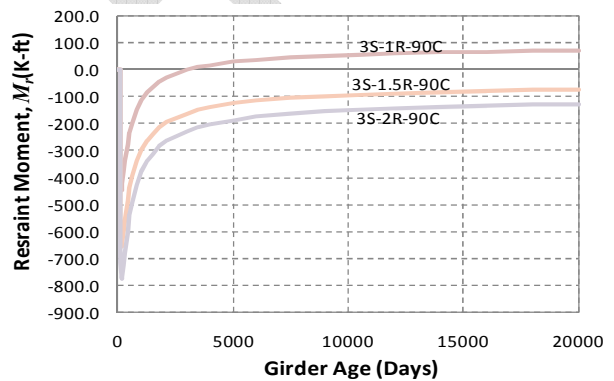
(a) Age = 180 days and $I_{dia} = 0.05I_g$



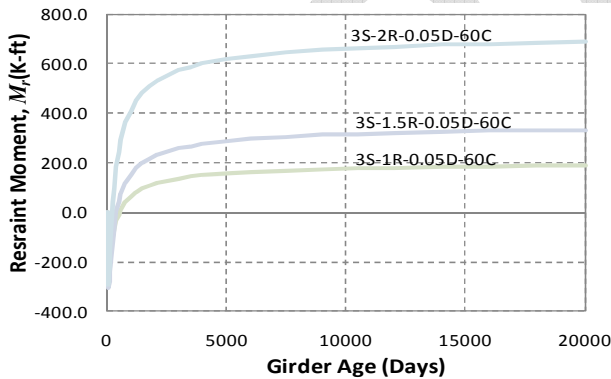
(a) Age = 180 days and $I_{dia} = 0$



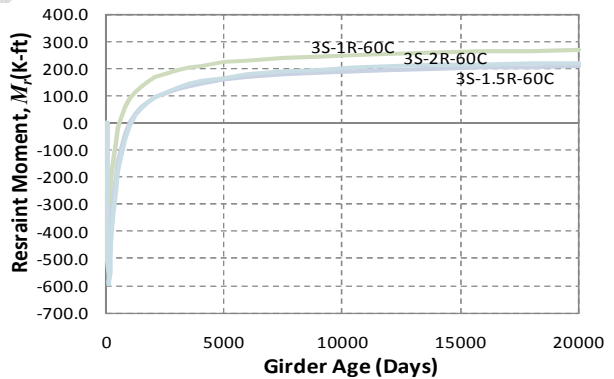
(b) Age = 90 days and $I_{dia} = 0.05I_g$



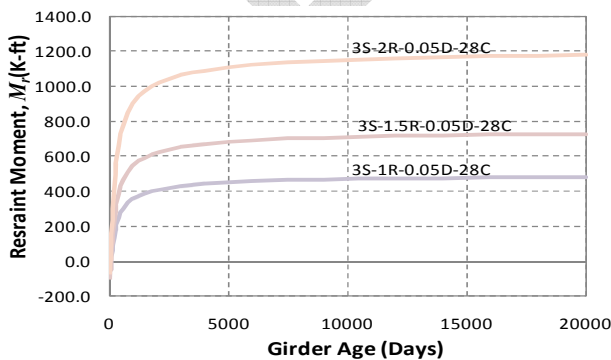
(b) Age = 90 days and $I_{dia} = 0$



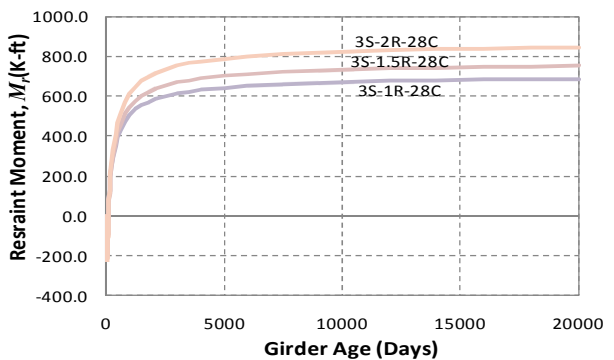
(c) Age = 60 days and $I_{dia} = 0.05I_g$



(c) Age = 60 days and $I_{dia} = 0$



(c) Age = 60 days and $I_{dia} = 0.05I_g$



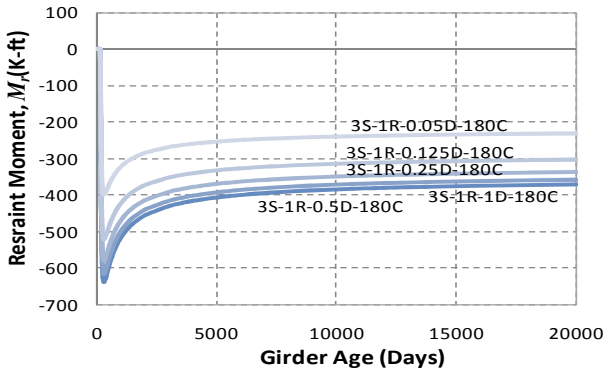
(c) Age = 60 days and $I_{dia} = 0$

(d) Age = 28 days and $I_{\text{dia}} = 0.05I_g$

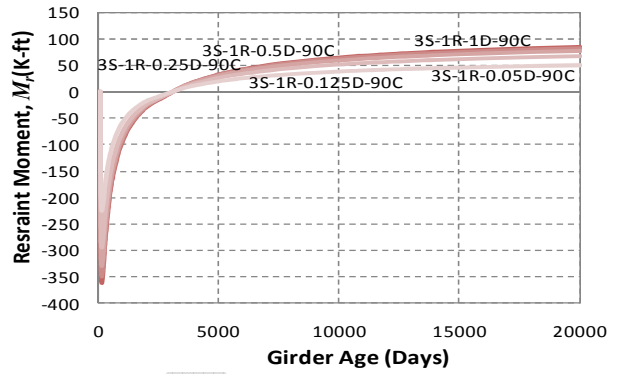
(d) Age = 28 days and $I_{\text{dia}} = 0$

Fig. XX -

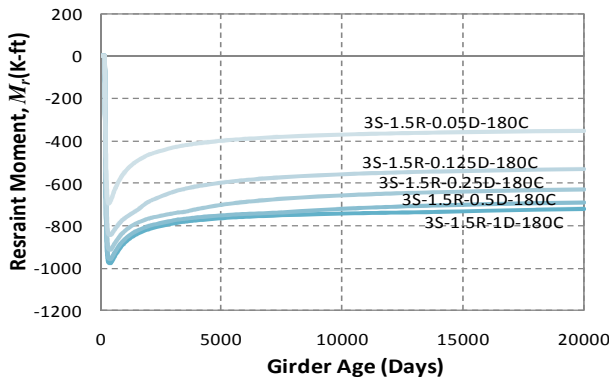
DRAFT



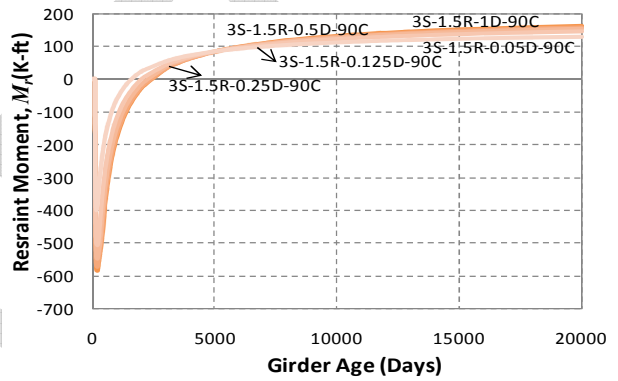
(a) $L_1 = L_2 = L_3$ and Age = 180 days



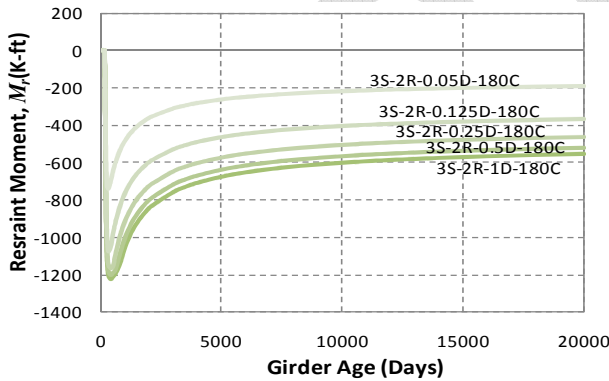
(a) $L_1 = L_2 = L_3$ and Age = 90 days



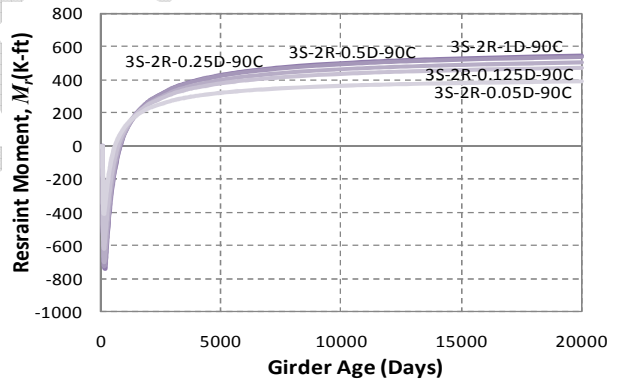
(b) $L_2 = 1.5 * L_1 = 1.5 * L_3$ and Age = 180 days



(b) $L_2 = 1.5 * L_1 = 1.5 * L_3$ and Age = 90 days

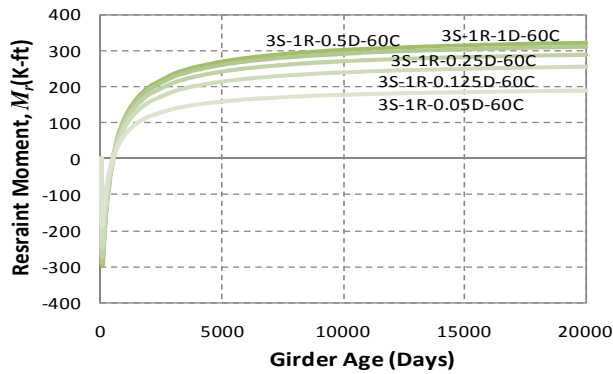


(c) $L_2 = 2 * L_1 = 2 * L_3$ and Age = 180 days

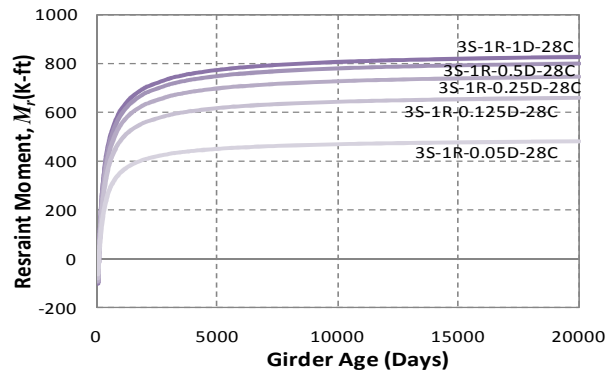


(c) $L_2 = 2 * L_1 = 2 * L_3$ and Age = 90 days

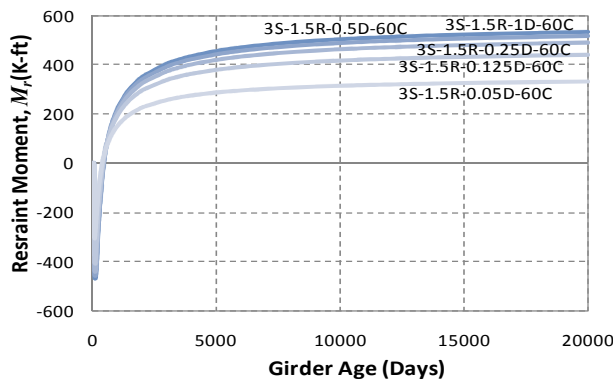
Fig. XX -



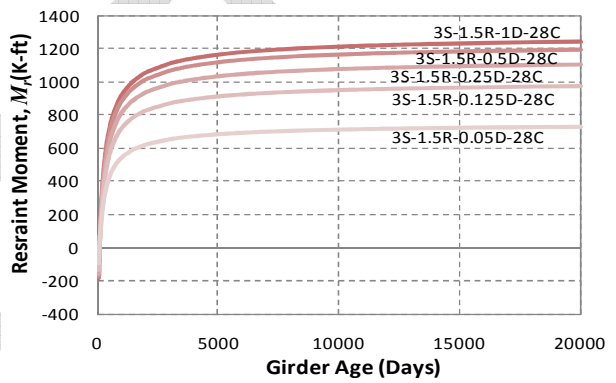
(a) $L_1 = L_2 = L_3$ and Age = 60 days



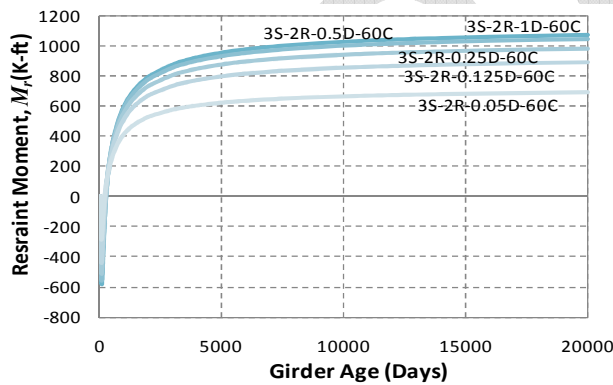
(a) $L_1 = L_2 = L_3$ and Age = 28 days



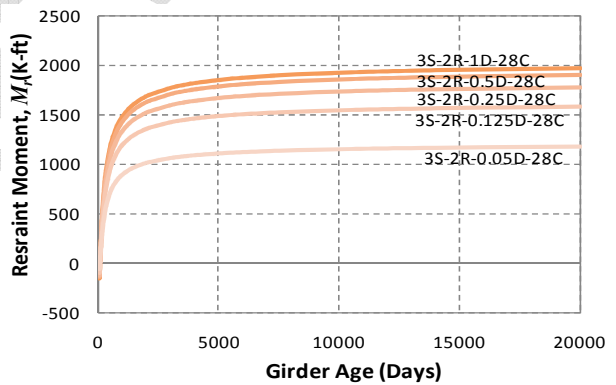
(b) $L_2 = 1.5 * L_1 = 1.5 * L_3$ and Age = 60 days



(b) $L_2 = 1.5 * L_1 = 1.5 * L_3$ and Age = 28 days



(c) $L_2 = 2 * L_1 = 2 * L_3$ and Age = 60 days



(c) $L_2 = 2 * L_1 = 2 * L_3$ and Age = 28 days

Fig. XX -