

SOIL-CEMENT STUDY

FINAL REPORT

BY

JAMES L. MELANCON
SOILS RESEARCH GEOLOGIST

AND

S. C. SHAH
DATA ANALYSIS ENGINEER

Research Report No. 72

Research Project No. 68-9S
Louisiana HPR 1 (11)

Conducted by
LOUISIANA DEPARTMENT OF HIGHWAYS
Research and Development Section
In Cooperation with
U. S. Department of Transportation
FEDERAL HIGHWAY ADMINISTRATION

"The contents of this report reflect the views of the authors who are responsible for the facts and the accuracy of the data presented herein. The contents do not necessarily reflect the official views or policies of the State or the Federal Highway Administration. This report does not constitute a standard, specification, or regulation."

November 1973

| | | | | | |
|---|--|--|--|----------------------------|-----------|
| 1. Report No. 72 | | 2. Government Accession No. | | 3. Recipient's Catalog No. | |
| 4. Title and Subtitle Soil-Cement Study | | | 5. Report Date November, 1973 | | |
| | | | 6. Performing Organization Code | | |
| 7. Author(s) J. L. Melancon and S. C. Shah | | | 8. Performing Organization Report No. 68-9S | | |
| 9. Performing Organization Name and Address Louisiana Department of Highways Research & Development Section P. O. Box 44245, Capitol Station Baton Rouge, Louisiana 70804 | | | 10. Work Unit No. | | |
| | | | 11. Contract or Grant No. | | |
| | | | 13. Type of Report and Period Covered Final March 1969 - December 1972 | | |
| 12. Sponsoring Agency Name and Address* Department of Transportation Federal Highway Administration | | | 14. Sponsoring Agency Code | | |
| 15. Supplementary Notes | | | | | |
| 16. Abstract This study consisted of an examination of the compressive strengths of soil-cement mixtures on 15 construction projects from the standpoint of design and actual achievement. The laboratory design test was examined closely along with the present field method of density control for soil-cement bases and the distribution of cement within the bases. The examination of the laboratory design test showed inconsistencies, inherent in the procedure, existed in the laboratory design method; therefore, additional controls were established in the testing procedure. In addition, a new cement recommendation system was developed and implemented. Field investigation indicated that, based on compressive strength, the quality of the soil-cement bases varies greatly both within an individual project and between different projects. Under the present construction techniques of cement application, and moisture control, it was found that 75 percent of the construction projects checked achieved 75 percent (225 psi) of the laboratory design strength (300 psi) at 28 days. Using the present method of controlling densities there is an implication of greater degree of compaction than actually achieved. Determination of cement contents of in-place mixed soil-cement bases indicated large variation within the bases and from the design percentages. | | | | | |
| 17. Key Words Soil-Cement, Soil-Cement Design, Compressive Tests, Statistical Analysis, Variability | | | 18. Distribution Statement | | |
| 19. Security Classif. (of this report) Unclassified | | 20. Security Classif. (of this page) Unclassified | | 21. No. of Pages 90 | 22. Price |

ACKNOWLEDGEMENTS

During the course of the study there were a number of changes in the key personnel assigned to this study. The authors wish to acknowledge the contribution of these people.

The work of numerous technicians of the Soils Research Unit headed by Sammie Fuller who directed the laboratory and field work of this study, and Alfred Moore in preparation of graphs and charts, is gratefully acknowledged.

The efforts of various District Laboratory personnel, in particular George Bass, Marrion Cryer and the technicians of the District 07 Laboratory, in sampling soils and design testing is certainly appreciated.

The close cooperation and help provided by the Soils and Chemical Units of the Materials Section during the entire study is very much appreciated.

Appreciation is expressed to Helene Melancon for her efforts in typing this final draft.

TABLE OF CONTENTS

| | |
|--|------|
| TECHNICAL REPORT STANDARD TITLE SHEET ----- | iii |
| ACKNOWLEDGEMENTS ----- | v |
| LIST OF TABLES ----- | vix |
| LIST OF FIGURES ----- | xiii |
| IMPLEMENTATION ----- | xvii |
| ABSTRACT ----- | xix |
| INTRODUCTION ----- | 1 |
| SCOPE ----- | 2 |
| METHODOLOGY ----- | 3 |
| DISCUSSION OF RESULTS ----- | 7 |
| Field Evaluation ----- | 7 |
| Investigation of Laboratory and Field Compressive Strengths ----- | 7 |
| Field Density Evaluation ----- | 14 |
| Variability of Cement Content of Bases ----- | 22 |
| EVALUATION OF LOUISIANA SOILS USED FOR SOIL-CEMENT STABILIZATION ----- | 28 |
| VARIABILITY OF LABORATORY DESIGN ----- | 31 |
| Statistical Analysis of Laboratory Design ----- | 31 |
| Investigation of Effect of Specimen Size and Molding Method ----- | 39 |
| Cement Recommendation System ----- | 48 |
| SUMMARY AND CONCLUSIONS ----- | 51 |
| RECOMMENDATIONS ----- | 53 |
| CITED REFERENCES ----- | 55 |
| SELECTED REFERENCES ----- | 56 |
| APPENDIX ----- | 57 |

LIST OF TABLES

| Table No. | Title | Page No. |
|-----------|---|----------|
| 1 | Compressive Strength Results of Projects Studied ----- | 10 |
| 2 | Compressive Strength of Cores ----- | 11 |
| 3 | Field Density Evaluation ----- | 15 |
| 4a | Cement Distribution ----- | 26 |
| 4b | Cement Distribution ----- | 27 |
| 5 | Effects of Delayed Compaction on Density and Compression Strength of Certain Soils ----- | 30 |
| 6 | Compressive Strength Results Obtained by Two Laboratories (Phase I) ----- | 32 |
| 7 | Compressive Strength Results Obtained by Three Laboratories (Phase II) ----- | 33 |
| 8 | Statistical Evaluation of Tri-Lab Data (Phase II) ----- | 34 |
| 9 | Compressive Strength Results Obtained by Three Laboratories (Phase III) ----- | 36 |
| 10 | Statistical Evaluation of Tri-Lab Data (Phase III) ----- | 37 |
| 11 | Analysis of Variance Table ----- | 38 |
| 12 | Compressive Strength Results of Bi-Lab Study (Phase IV) ---- | 40 |
| 13a | Statistical Evaluation of Bi-Lab Data (Phase IV) ----- | 41 |
| 13b | Statistical Evaluation of Bi-Lab Data (Phase IV) ----- | 42 |
| 14 | Compressive Strength Results of District Laboratory Time A versus Time B ----- | 43 |
| 15a | Statistical Evaluation of District Laboratory Data Time A versus Time B ----- | 44 |
| 15b | Statistical Evaluation of District Laboratory Data Time A versus Time B ----- | 45 |
| 15c | Statistical Evaluation of District Laboratory Data Time A versus Time B ----- | 46 |
| 16 | Results of Statistical "t" Test for Unimpaired Data ----- | 47 |

LIST OF TABLES (CONTINUED)

| Table No. | Title | Page No. |
|-----------|--|----------|
| 17 | Compressive Strength Results of Specimens Having Different Length to Diameter Ratios ----- | 49 |
| 18 | Soil-Cement Requirement Chart ----- | 50 |

LIST OF FIGURES

| Figure No. | Title | Page No. |
|------------|--|----------|
| 1 | Molding Soil-Cement Specimens in the Field ----- | 4 |
| 2 | Extruding Soil-Cement Specimens in the Field ----- | 4 |
| 3 | Field Curing of Soil-Cement Specimens ----- | 5 |
| 4 | Distribution of Projects Studied ----- | 8 |
| 5 | Mean Percentages of Project Compressive Strengths Equal to or Greater Than Indicated PSI in Each Category ----- | 12 |
| 6 | Illustration of Theoretical Minimum Acceptable Densities for Two Soils Under the Present Field Compaction Control Method - | 16 |
| 7 | Representative Strength-Compaction Curves ----- | 18 |
| 8 | Frequency Occurrence of Actual versus Theoretical Cement Contents ----- | 20 |
| 9 | Ogive for Distribution of Actual versus Theoretical Cement Contents ----- | 21 |
| 10a | Cement Loss Due to Spreading Beyond Limits of Base ----- | 23 |
| 10b | Cement Loss During Application ----- | 23 |
| 11a | Loss of Soil-Cement Mixture During Final Blading ----- | 24 |
| 11b | Non-Uniform Distribution of Cement in Base ----- | 24 |
| 12 | Percentages of Project Compressive Strengths Equal to or Greater Than Indicated PSI in Each Category ----- | 68 |
| 13 | Percentages of Project Compressive Strengths Equal to or Greater Than Indicated PSI in Each Category ----- | 69 |
| 14 | Percentages of Project Compressive Strengths Equal to or Greater Than Indicated PSI in Each Category ----- | 70 |
| 15 | Percentages of Project Compressive Strengths Equal to or Greater Than Indicated PSI in Each Category ----- | 71 |
| 16 | Percentages of Project Compressive Strengths Equal to or Greater Than Indicated PSI in Each Category ----- | 72 |
| 17 | Percentages of Project Compressive Strengths Equal to or Greater Than Indicated PSI in Each Category ----- | 73 |

LIST OF FIGURES (CONTINUED)

| Figure No. | Title | Page No. |
|------------|--|----------|
| 18 | Percentages of Project Compressive Strengths Equal to or Greater Than Indicated PSI in Each Category ----- | 74 |
| 19 | Percentages of Project Compressive Strengths Equal to or Greater Than Indicated PSI in Each Category ----- | 75 |
| 20 | Percentages of Project Compressive Strengths Equal to or Greater Than Indicated PSI in Each Category ----- | 76 |
| 21 | Percentages of Project Compressive Strengths Equal to or Greater Than Indicated PSI in Each Category ----- | 77 |
| 22 | Percentages of Project Compressive Strengths Equal to or Greater Than Indicated PSI in Each Category ----- | 78 |
| 23 | Percentages of Project Compressive Strengths Equal to or Greater Than Indicated PSI in Each Category ----- | 79 |
| 24 | Percentages of Project Compressive Strengths Equal to or Greater Than Indicated PSI in Each Category ----- | 80 |
| 25 | Percentages of Project Compressive Strengths Equal to or Greater Than Indicated PSI in Each Category ----- | 81 |
| 26 | Percentages of Project Compressive Strengths Equal to or Greater Than Indicated PSI in Each Category ----- | 82 |
| 27a | Comparison of Design By Tri-Labs (Phase II) ----- | 83 |
| 27b | Comparison of Design By Tri-Labs (Phase II) ----- | 84 |
| 27c | Comparison of Design By Tri-Labs (Phase II) ----- | 85 |
| 28a | Comparison of Design By Tri-Labs (Phase III) ----- | 86 |
| 28b | Comparison of Design By Tri-Labs (Phase III) ----- | 87 |
| 28c | Comparison of Design By Tri-Labs (Phase III) ----- | 88 |
| 29 | Comparison of Design By Two-Labs (Phase IV) ----- | 89 |
| 30 | Comparison of Design By District Lab (Time A versus Time B)- (Phase IV) ----- | 90 |

IMPLEMENTATION

The scope of this study consisted of an examination of the compressive strengths of soil-cement mixtures on 15 construction projects, from the standpoint of design and actual achievement. The laboratory design test was examined closely along with the present field method of density control for soil-cement bases and the distribution of cement within the bases.

Implementation of the findings related to the laboratory design procedure was initiated during the course of study. The examination of the laboratory design test showed that excessive inconsistency existed when using the laboratory design method established shortly after the commencement of this study. This inconsistency has been reduced by implementation of a new test procedure.

A new cement recommendation system based upon compressive strength, A-group, soil types and geographic location was developed and has been implemented. Basically, this system consists of charts indicating cement content necessary to achieve 250 and 300 psi at seven days in the laboratory for specific soil types within a geographic area.

Field investigation indicated that, based on compressive strength, the quality of the soil-cement bases varies greatly both within an individual project and between different projects. In order to achieve more uniformity on a soil-cement base as well as a better end product, several recommendations are being made concerning field testing procedures and construction techniques. These recommendations consist of (1) changing the method presently used for compaction control, (2) requiring the use of central plant (pugmill) mixing of soil-water-cement, (3) determining the distribution of cement during construction and, (4) disallowing the practice of blending non-suitable soils with suitable soils on the roadway in order to produce material for soil-cement bases. It is also recommended that field studies be initiated on the use of a chemical additive which would counteract the detrimental effects of delayed compaction.

The recommended changes in field procedure and specifications will require close study; however, implementation of these findings should result in an improved, more consistent end product.

ABSTRACT

The scope of this study consisted of an examination of the compressive strength of soil-cement mixtures on 15 construction projects, from the standpoint of design and actual achievement. The laboratory design test was examined closely along with the present field method of density control for soil-cement bases and the distribution of cement within the bases.

The examination of the laboratory design test showed that excessive inconsistency existed when using the laboratory design method established shortly after the commencement of this study. This testing variability was found to be inherent in the procedure and not due to careless testing techniques. This inconsistency has been reduced by establishing additional controls within the testing procedure.

A new cement recommendation system based upon compressive strength, A-group, soil types and geographic location was developed and has been implemented. Basically, this system consists of charts indicating cement content necessary to achieve 250 and 300 psi at seven days in the laboratory for specific soil types within a geographic area.

Field investigation indicated that, based on compressive strength, the quality of the soil-cement bases varies greatly both within an individual project and between different projects. Under the present construction techniques of cement application, density and moisture control, a fair product is produced with 75 percent of the construction project stations checked having achieved 75 percent (225 psi) of the laboratory design strength (300 psi) at 28 days. For those projects studied in which the laboratory design criteria was based on compressive strength, the raw soils sampled and tested in the laboratory showed substantial verification of the Materials Laboratory design.

The present method of controlling densities of soil-cement bases in the field contains several undesirable features. When using this method, there is an implication of greater density than actually achieved. In-place mixing of cement with soil appears to be somewhat less than desirable. Results of soil-cement bases studied showed a variation of ± 5 percent from the theoretical cement content.

INTRODUCTION

Soil-cement stabilization has played a major role in highway construction in Louisiana for many years, and it can be assumed that this role will continue for many more years to come. Therefore, designation of the proper percent of Portland cement needed to produce a quality product at economically feasible costs is very important in highway construction.

In Louisiana, the laboratory design test for determining the optimum cement content for soil-cement stabilized bases prior to initiation of this study was one based on durability, specifically the wet-dry test. However the deterioration of soil-cement base courses prior to attainment of the design service life led to a re-evaluation of the design method based on durability. Shortly after the commencement of this study a new laboratory design method was established consisting of three criteria: (1) compressive strength (300 psi), (2) durability (the freeze-thaw test), and (3) the requirements of the Louisiana Slope-Value Method. Because of the nature of the tests, the critical determination was the one for compressive strength since it acted as the controlling factor in about 98 percent of the decisions concerning material acceptability. In addition, when the material is found acceptable, the compressive strength determined the amount of cement necessary for stabilization.

A major change in the laboratory design method was initiated after an unanticipated discovery was made: the soil-cement laboratory design procedure based upon compressive strength limits exhibited a greater amount of variability than previously acknowledged. In close cooperation with the Material Section's Soil Unit, a system based upon compressive strength, A-group, soils type, and geographical location was developed. Two sets of charts were developed in which the optimum cement contents necessary for achieving 300 psi and 250 psi in the laboratory were listed for various soil types within a specified geographic area. However, for soils having high silt contents the procedure is to actually perform compressive strength tests, and in some cases, durability tests (freeze-thaw). The method using charts developed has been implemented and is being used for selecting optimum cement content for cement treated bases in Louisiana.

The percentage of laboratory design strength that was achieved in soil-cement bases on 15 projects was determined. Also, the degree of compaction obtained in the soil-cement bases (as based on the present field determined maximum values versus the laboratory design values for the same materials) and the uniformity of cement content within the soil-cement bases were investigated on the 15 projects.

It is important to realize that this report deals with soil-cement that has been stabilized in-place, and not with stabilized aggregates and/or central plant (pugmill) mixed soil-cement. The soil-cement in Louisiana is constructed with soils having an A-group of A-2-4, A-3, A-4, and A-6 and plasticity indices ranging from non-plastic to a maximum of 15. Another important factor to remember is that the compressive strengths of 300 and 250 psi are empirically derived values for the laboratory determination of optimum cement contents and acceptability of soils for stabilization. The basis of soil-cement section design in Louisiana at the present time, is the AASHO design coefficient of .15 representing 300 psi for soil-cement.

SCOPE

The object of this study was to evaluate compressive strength criteria for soil-cement base courses in Louisiana.

The scope of this study was to determine the percentage of laboratory design strength that may be expected of soil-cement stabilized bases in Louisiana. To determine this percentage, the compressive strength test results of cores and field molded specimens from soil-cement base courses on construction projects were compared to the respective laboratory soil-cement design values.

This study was extended to examine the existing system of recommending cement design percentage for soil-cement base construction, which in turn led to an investigation of the reliability of the laboratory design test itself. The methods used for determining percent compaction and the cement variation in the bases were also examined.

METHODOLOGY

The final objective of evaluating the compressive strength criteria for soil-cement bases in Louisiana was achieved. This was accomplished by laboratory testing of a wide range of soils. During the process the compressive strength test results of cores and field molded specimens from soil-cement base courses on construction projects were compared to the respective laboratory design values.

The procedure consisted of laboratory testing of soils sampled from fifteen active soil-cement projects prior to the addition of cement, sampling and testing of soil-cement mixture from the bases and testing cores at various curing stages of the base (see Table 1 and 2). Also a reliability study of the laboratory design test was undertaken. This testing procedure was accomplished in the following manner.

Samples of the soil to be stabilized were obtained from the roadway on soil-cement projects prior to the addition of the cement. These samples were taken at minimum intervals of one mile or at each change in soil type, whichever was less. These soils were then tested for laboratory compressive strength at cement contents ranging from 6 to 16 percent by weight. (Procedures of all tests performed are detailed in the Appendix).

Additional samples were taken from the same areas on the roadway after the addition of the cement and immediately after completion of moist mixing. Utilizing these materials, proctor size specimens were immediately molded in the field using the same equipment and compactive effort as in the laboratory design procedure (Figure 1). Eight specimens were left in the field for curing and eight were left in the molds (six and three specimens respectively for Project 1 through 9), placed in airtight bags and transported to the laboratory. At the laboratory, the specimens were removed from the plastic bags, extruded from the molds and placed in a moist room for curing. After curing for seven days they were tested for compressive strength.

The specimens molded in the field and not brought immediately to the laboratory were extruded from the proctor molds, then buried in the shoulder or backslope of the roadway at the station sampled and left to cure for a period of 7 and 28 days (Figures 2 and 3). At the end of either curing period, the specimens were removed from the curing site, placed in airtight plastic bags and transported to the laboratory for compressive strength testing.

After the soil-cement base course had cured for 7 and 28 days, cores were taken at the same stations where raw soil had been obtained and soil-cement specimens had been made previously. These cores were brought to the laboratory for compressive strength testing. The entire core obtained was tested after a minimum of trimming. Strength values were corrected to an L over D ratio of 1.146:1 in order to be compared to proctor size specimens molded in the laboratory and field. Cores were also taken after longer curing periods of the base on some of the projects.

Cement content of cores and of selected soil-cement specimens molded in the laboratory and in the field were determined by chemical analysis.



MOLDING SOIL-CEMENT SPECIMENS IN THE FIELD
FIGURE 1

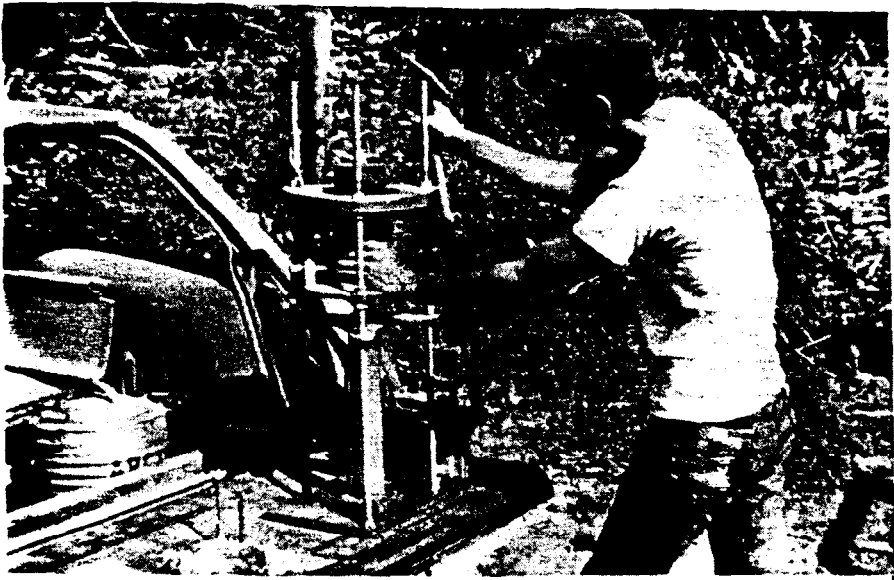

EXTRUDING SOIL-CEMENT SPECIMENS IN THE FIELD
FIGURE 2



FIELD CURING OF SOIL-CEMENT SPECIMENS
FIGURE 3

The reliability study of the laboratory design test was conducted in four stages.

First, the researchers and one District Laboratory performed compressive strength tests using two soil types obtained by the researchers, using the same type of equipment and procedure outlined in the Appendix. The design data in this case was formulated by the researchers.

The second stage consisted of the same testing program as that of the first; however, in this case the Soil Unit of the Materials Section (the unit responsible for performing soil-cement designs) along with a District Laboratory and the researchers conducted the testing.

Third, the three laboratories performed design tests on three soil types furnished by the researchers. This work differed from the previous work in that several steps of the design procedure were more closely controlled than normally required.

These controls consisted of:

- (1) Adjusting each component in the fabrication of soil-cement specimens to the same temperature ($75^{\circ}\text{F} \pm 5^{\circ}\text{F}$) prior to molding the specimens.
- (2) Adding water to the raw soils and slaking overnight before addition of cement.
- (3) Holding uniform the time involved in fabrication of specimens.

The specimen density and moisture content were closely controlled between the three laboratories by using the same density and optimum moisture for specimen design for each material tested.

The fourth stage of the reliability study consisted of obtaining and testing soil samples from each of the nine highway districts of the State. Each sample was divided into two equal parts, one part for testing by the Soils Research Laboratory and the other part by the District 07 Laboratory. Soil-cement design tests performed for each soil type by both laboratories. Additionally, District 07 Laboratory reran the same test on the same soils two weeks after completing the first series. Both series were treated as separate samples in all respects. Cement content design data was developed by each laboratory for its testing in each case.

This was done as a check on reliability of the modified design test between laboratories and for the same laboratory retesting the same soil.

DISCUSSION OF RESULTS

An Interim Report (1)* was written at the completion of data collection on the first nine projects listed in Table 1. Continued research effort has added data to this from six other soil-cement projects. This discussion will encompass the results obtained during the study of all fifteen projects.

As discussed in the Interim Report, trends which were logically based were indicated in the data of the first nine projects. The additional data obtained on Projects ten through fifteen verify the conclusions reached at that time. A check of total averages for compressive strength and density results from all fifteen projects shows very little change from the averages of the nine projects previously reported, even though the addition data was collected from projects where much higher amounts of cement were used for stabilization.

Field Evaluation

The Statewide distribution (Figure 4) of the fifteen projects studied has resulted in a coverage of virtually all major soil types used in soil-cement bases in Louisiana. The soils range from those with high silt contents to high sand contents, and include those soils having plasticity indices up to fifteen. The amount of cement covered the full range presently used in Louisiana: from eight percent to fourteen percent by volume. Many variables come into play when analyzing results of only two different soil types; therefore, with the addition of several different soil types of varying geologic ages and sources and in combination with a chemical agent, the variables are so multiplied that it is almost impossible to analyze results. For this reason the method of analysis used in this study for evaluating field results is divided into two categories: (1) a close scrutiny of the averages of the various results, with high and low values noted in order to show data variability, and (2) a percentage of achievement of specified compressive strength values, in each mode of sampling and curing, for each station sampled on each project.

The first category presents a valid means of analyzing the data for an overall view of results. However, it also shows the variability that exists in the compressive strengths of the soil-cement bases studied. Therefore, a second or more detailed analysis is made whereby the results of each station sampled on all projects are checked in respect to percent achievement of specified compressive strength levels.

Investigation of Laboratory and Field Compressive Strengths

(1) Analysis of Project Averages

Table 1 contains the very core of the research: compressive strength is examined from the standpoint of laboratory design and actual achievement. The specimens molded and cured in the laboratory represent ideal conditions. This is a check for each project as to the validity of the recommended amount of cement for each respective soil type. The specified percentage of cement was applied in each case; the mixing, moisture control, density and curing were rigidly controlled. The resultant individual job averages ranged from 216 psi to 532 psi, the mean of the total jobs being 385 psi at seven days.

*(1) Underlined numbers in parenthesis refers to list of references.

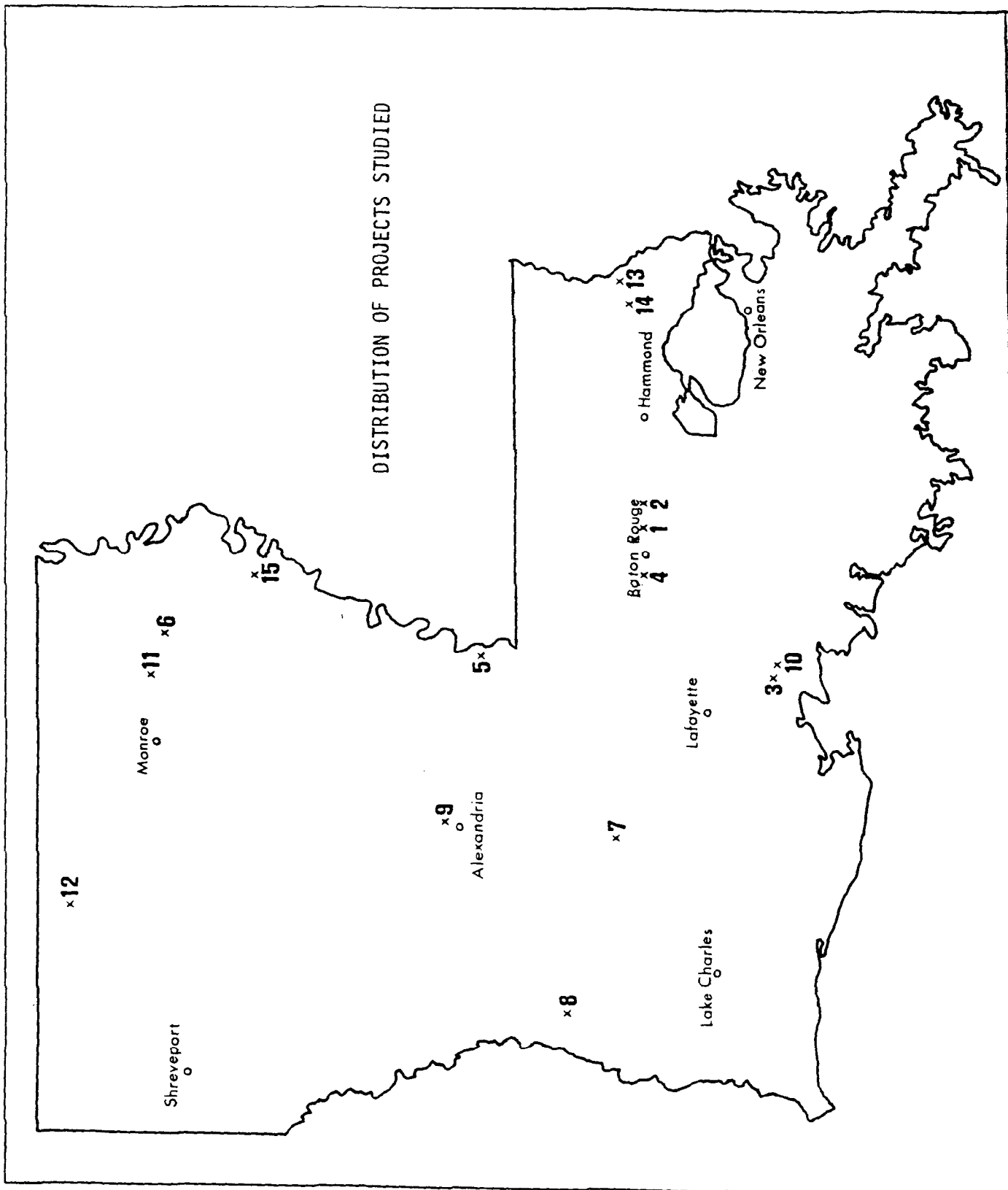

FIGURE 4

It should be noted here that recommendation of cement quantities for Project Nos. 1 through 6 were based on the wet-dry test tested according to PCA(2) recommended procedures. These projects were checked and included here because, even though a durability test determined the percentage of cement, 300 psi was used for roadway section design purposes. As indicated, averages of two of the first six projects did not reach 300 psi. A soil meeting the brush loss criteria of the wet-dry test will not necessarily achieve 300 psi at the same cement content in 7 days, especially where silty soils are encountered as in these two cases. It is important to note that silty soils are one of the major soil types used in several areas of Louisiana. This laboratory design procedure has been changed to compressive strength criteria during this study.

The laboratory molded averages for Project Nos. 7 through 15 were all above 300 psi, with 95 percent of all stations tested meeting or surpassing the 300 psi criteria.

The field molding of specimens presents a true check on the design, somewhat similar to that of concrete cylinders fabricated in the field as a check of concrete design. These specimens added the field mixed variables of moisture control (theoretically between two percent below optimum moisture to two percent above optimum moisture), cement content (varied according to uniformity of spread and/or to depth of cut) and the time delay between the incorporation of cement with the soil and initiation of compaction. The compaction effort was held constant at standard proctor.

The total average of the specimens molded in the field and cured in the laboratory for seven days, was 271 psi and for 28 days (Projects 10 through 15) 412 psi. This is about 70 percent of the laboratory strength at 7 days and 107 percent of the laboratory strength at 28 days based upon the mean (385 psi). This reasonably checks the laboratory design strength.

The average of the specimens molded and cured in the field was 241 psi (7 day cure) and 303 psi (28 day cure). This is 63 percent and 79 percent of the laboratory strength, respectively, at 7 and 28 days and based on the mean (385 psi).

The results of the field cores, Tables 1 and 2, should most truly represent actual field results since all variables and all interplay that could possibly influence relationships were available. However, it should be realized that the core results probably reflect slightly better than true conditions since the results do not consider those specimens damaged in collection (probably due to a localized weak area). An attempt was made to obtain 1122 cores; 732 core results were actually obtained. Cores were taken at 7 and 28 days on all projects and at various other time intervals on projects not having concrete pavement surfacing. The average of 7 day cores was 211 psi and 28 days was 346 psi. This is 55 and 90 percent, respectively, of the design strength based on the mean.

The average results of cores at 7 and 28 days, and all other averages, indicate that for the projects checked, a fair product was produced. However, the results also show a large variation in compressive strength on nearly all projects. An example is that the compressive strength of cores at 28 days

TABLE 1
COMPRESSIVE STRENGTH RESULTS OF PROJECTS STUDIED

| Research Project Number | Predominate Soil Classification | Compressive Str. of Lab. Molded Specimens | | | | | | Compressive Strength of Field Molded Specimens | | | | | | | | | | | | Compressive Strength of Cores | | | | | |
|-------------------------|---|---|------|-----|--------------------------|------|-----|--|------|-----|--------------------------|------|-----|--------------------------|------|-----|---------------------------|------|-----|-------------------------------|------|-----|----------------|------|-----|
| | | 7 day Lab. Cure Project | | | 28 day Lab. Cure Project | | | 7 day Lab. Cure Project | | | 28 day Lab. Cure Project | | | 7 day Field Cure Project | | | 28 day Field Cure Project | | | 7 day Project | | | 28 day Project | | |
| | | Average | High | Low | Average | High | Low | Average | High | Low | Average | High | Low | Average | High | Low | Average | High | Low | Average | High | Low | Average | High | Low |
| 1 | Silty Clay Loam A-4(B) | 252 | 325 | 170 | | | | 284 | 404 | 162 | | | | 221 | 326 | 123 | 284 | 462 | 130 | 228 | 346 | 124 | 375 | 732 | 126 |
| 2 | Clay Loam A-6(B) | 465 | 595 | 345 | | | | 221 | 343 | 101 | | | | 178 | 235 | 99 | 254 | 415 | 121 | 199 | 292 | 115 | 264 | 400 | 176 |
| 3 | Silty Clay Loam A-4(B), A-6(B) | 320 | 380 | 245 | | | | 191 | 310 | 145 | | | | 180 | 300 | 129 | 229 | 448 | 114 | 225 | 312 | 142 | 298 | 503 | 121 |
| 4 | Clay Loam A-4(7) Silty Clay Loam A-4(B) | 328 | 365 | 305 | | | | 158 | 163 | 149 | | | | 142 | 158 | 132 | 166 | 182 | 146 | 150 | 154 | 147 | 248 | 328 | 202 |
| 5 | Silty Loam A-4(B) | 216 | 290 | 170 | | | | 115 | 151 | 76 | | | | 136 | 177 | 97 | 166 | 246 | 113 | - | - | - | - | - | - |
| 6 | Sandy Loam A-2-4(0), A-4(1) | 388 | 415 | 319 | | | | 296 | 345 | 245 | | | | 283 | 340 | 235 | 300 | 433 | 225 | 278 | 285 | 270 | 474 | 619 | 218 |
| 7 | Sandy Loam A-4(3) | 301 | 370 | 255 | | | | 260 | 408 | 94 | | | | 173 | 271 | 68 | 224 | 363 | 75 | 187 | 265 | 70 | 234 | 338 | 149 |
| 8 | Sandy Loam A-4(3) Silty Clay Loam A-6(10) | 455 | 485 | 425 | | | | 417 | 450 | 384 | | | | 357 | 376 | 338 | 438 | 438 | 438 | 263 | 340 | 185 | 443 | 534 | 352 |
| 9 | Sandy Loam A-2-4(0) | 424 | 500 | 395 | | | | 233 | 340 | 178 | | | | 222 | 251 | 197 | 268 | 391 | 163 | 138 | 217 | 90 | 249 | 402 | 143 |
| 10 | Silty Clay Loam A-6(B) | 480 | 542 | 429 | 671 | 814 | 611 | 289 | 363 | 232 | 478 | 581 | 375 | 235 | 333 | 182 | 443 | 530 | 281 | 367 | 432 | 332 | 732 | 1057 | 546 |
| 11 | Sandy Loam A-4(2) Silty Loam A-4(B) | 455 | 561 | 408 | 642 | 801 | 600 | 286 | 410 | 200 | 368 | 504 | 312 | 309 | 434 | 207 | 381 | 536 | 195 | 238 | 508 | 100 | 302 | 429 | 175 |
| 12 | Sandy Loam A-2-4(0) Sandy Clay Loam A-2-4(0) | 443 | 482 | 398 | 681 | 778 | 624 | 274 | 321 | 242 | 436 | 562 | 358 | 261 | 398 | 197 | 352 | 497 | 262 | 177 | 224 | 106 | 250 | 332 | 132 |
| 13 | Sandy Loam A-4(2) Sandy Clay Loam A-4(1) | 340 | 400 | 252 | 698 | 802 | 555 | 416 | 621 | 211 | 452 | 546 | 320 | 402 | 573 | 206 | 424 | 546 | 240 | 209 | 285 | 112 | 314 | 635 | 119 |
| 14 | Loam A-4(B) Silty Loam A-4(B) | 532 | 594 | 497 | 960 | 1086 | 832 | 490 | 528 | 428 | 580 | 633 | 439 | 391 | 443 | 280 | 496 | 619 | 317 | 149 | 215 | 109 | 410 | 607 | 224 |
| 15 | Sandy Loam A-2-4(0) | 373 | 433 | 304 | 556 | 643 | 467 | 134 | 240 | 49 | 156 | 217 | 59 | 127 | 222 | 30 | 120 | 190 | 25 | 146 | 190 | 102 | 246 | 380 | 93 |
| Total Average | | 385 | | | 701 | | | 271 | | | 412 | | | 241 | | | 303 | | | 211 | | | 346 | | |

TABLE 2
COMPRESSIVE STRENGTH OF CORES

| Research Project Number | 7 day Cores | | | 28 day Cores | | | 3 Month Cores | | | 6 Month Cores | | | 9 Month Cores | | | 12 Month Cores | | | 18 Month Cores | | |
|-------------------------|-----------------|------|-----|-----------------|------|-----|-----------------|------|-----|-----------------|------|-----|-----------------|------|-----|-----------------|------|-----|-----------------|------|-----|
| | Project Average | High | Low | Project Average | High | Low | Project Average | High | Low | Project Average | High | Low | Project Average | High | Low | Project Average | High | Low | Project Average | High | Low |
| 7 | 187 | 265 | 70 | 234 | 338 | 149 | | | | | | | | | | 755 | 1047 | 522 | | | |
| 8 | 263 | 340 | 185 | 443 | 534 | 352 | | | | | | | | | | | | | 783 | 895 | 670 |
| 10 | 367 | 432 | 332 | 732 | 1057 | 546 | 938 | 1045 | 760 | | | | | | | | | | | | |
| 11 | 238 | 508 | 100 | 302 | 429 | 175 | | | | 425 | 718 | 272 | | | | 860 | 1075 | 653 | | | |
| 12 | 177 | 224 | 106 | 250 | 332 | 132 | | | | 781 | 966 | 586 | | | | | | | | | |
| 13 | 209 | 285 | 112 | 314 | 635 | 119 | | | | | | | 726 | 1048 | 433 | | | | | | |
| 14 | 149 | 215 | 109 | 410 | 607 | 224 | | | | | | | 649 | 1107 | 424 | | | | | | |
| 15 | 146 | 190 | 102 | 246 | 380 | 93 | | | | 709 | 1012 | 472 | | | | | | | | | |

ranged from a low at one station of 93 psi to a high at another station of over 1000 psi. The average of compressive strength for each project cored at three months or later does indicate the achievement of well over 300 psi. Only one station of Project No. 11 had a compressive strength less than 300 (272 psi); however, when checked at the end of 12 months the psi at this station was 1011.

(2) Percent Achievement of Specified Compressive Strength for Stations Sampled on Projects

Figure 5 shows the mean percentages of all tests achieving specified compressive strengths in each mode of sampling and curing category. A similar presentation of data for each project is contained in the Appendix, Figures 12 through 26. This data for individual projects takes into account tests run on material from all stations on each respective project.

The mean compressive strength of all projects for 7 day laboratory mold-lab cured equal to or greater than 300 psi is 82 percent. This mean includes compressive strength results of materials in which the cement quantity recommendations (Projects 1 through 6) were originally based on the wet-dry brush test, as well as those actually based on 300 psi. The projects in which compressive strength was used for cement recommendations show substantial verification of the Materials Laboratory design, with only one of these projects having soil types in which less than 300 psi was obtained at the recommended cement percentage.

The mean of the 28 day field mold-laboratory cured specimens is 83 percent. Soils from Projects 10 through 15 were checked in this matter, and all but one of the six projects achieved 300 psi or greater. This does indicate that for the five projects achievement of design strength can be expected after proper compaction effort and curing period.

The mean for 28 day cores for all projects is 53 percent. Only two projects achieved 300 psi or greater, and in one case (Project 10) the stabilized material contained high silt contents. It should be noted that this project had only 17 percent of in-place density tests below 95 percent design density (Table 3).

It is shown by the data in Tables 1 and 2 and Figure 5 that the strength gain of soil-cement bases is slow. The design strength of 300 psi was achieved or exceeded on the projects cored and tested at three months or later. The compressive strengths of these cores as well as those obtained during a previous Louisiana soil-cement research project (A Rapid Method for Soil-Cement Designs)(3) do not indicate that an increase in 7 day laboratory design strength is needed for assurance of obtaining the design value presently used by the Design Section. However, it is necessary to get design strength by the time the road is opened to traffic. The majority of soil-cement is not placed in service immediately; a practical time lapse between construction and use is approximately six months. The data from this project and from the other research project indicates this can be achieved. Another consideration is that the base should have sufficient strength to support some construction traffic. It is felt that a compressive strength of 225 psi at 28 days would be sufficient for this purpose. However, the specifications should disallow overweight construction traffic use.

The high values achieved at six months and later seem to indicate a possibility of reducing the cement content, however, this should be done with caution for when one looks at this data based on the average, we have as many poor areas as we have good areas. Under the present construction techniques of cement application, density and moisture control, a fair product is produced with 75 percent of the stations having achieved 75 percent (225 psi) of the design strength. Non-uniformity in the soil-cement bases checked seems to be more prevalent than insufficient cement for proper stabilization.

The non-uniformity of soil-cement bases in Louisiana was verified to some extent by the Louisiana AASHO Correlation Study No.(4). The Performance Index formula, as presented by the AASHO Committee, was reasonably verified by the various base courses presently used in Louisiana. Soil-cement base courses were also among these and, like the others, reasonably verified this formula on-the-average. However, individually, the soil-cement jobs varied to a much greater extent than the other materials; many jobs performed much better than expected, but an equal number performed inadequately.

Variability of test results from soil-cement bases, due to the wide range of construction techniques and other factors, did complicate the analysis of study data. For example: during the course of the Correlation Study, evaluation of performance for section design of soil-cement bases was attempted initially from compressive strength determinations of base cores. Strength results of cores showed variations within any single sample area as well as confounding conclusions on total roadway performance of the soil-cement base. That is for some areas the strength results of cores indicated high performance for soil-cement base section design; however, the total picture of the roadway indicated that the section with soil-cement base was near the end of its useful life. The reverse of this condition was also found. As a result this approach for evaluation of performance for soil-cement bases was discontinued.

Analysis of deflection data of the Correlation Study did result in development of performance prediction equation for soil cement sections. However, the soil-cement data differed from that of the other bases studied in that two distinct and separate equations for prediction of performance were derived from test data.

Field Density Evaluation

In the past, many problems occurred with project density control when using laboratory molded curves as the basic unit because of soil type inconsistency, difficulty of matching soils with curves and differences between construction time and laboratory time in molding curves. Therefore, the Department adopted a method whereby a location is selected for testing, two one-point proctors are run and the results averaged. This average value is used as the maximum laboratory density. An in-place density test is then run in the same exact location, compared to the maximum density value obtained from the two one-point proctors and reported as percent compaction. During rolling, moisture content is theoretically kept within two percent of optimum. When the moisture content is at optimum, the maximum density should be very near the same value as the maximum density of a laboratory curve; therefore when the moisture content varies from optimum, the maximum density is less than the same maximum density of the laboratory curve.

TABLE 3
FIELD DENSITY EVALUATION

| Project | Actual Roadway Density | Actual Density of Field Proctor Test | Lab Design Maximum Density | Ratio of | Actual % | Percent of |
|---------------|---------------------------|--|----------------------------------|--|--|---|
| | | | | Present Require. vs Lab Design Density | Compaction Based upon Lab Design Density | Research Tests Below 95% Design Density |
| | A | B | C | $\frac{B \times 95\%}{C} \times 100$ | $\frac{A}{C} \times 100$ | |
| 1 | 108.3 | 108.0 | 112.2 | 91 | 97 | 42 |
| 2 | 110.6 | 113.3 | 118.6 | 91 | 93 | 67 |
| 3 | 100.2 | 100.3 | 107.8 | 88 | 93 | 92 |
| 4 | 108.1 | 107.6 | 111.6 | 92 | 97 | 0 |
| 5 | 101.2 | 102.5 | 110.1 | 88 | 92 | 86 |
| 6 | 108.4 | 109.1 | 116.1 | 89 | 93 | 75 |
| 7 | 107.3 | 109.1 | 115.0 | 90 | 93 | 75 |
| 8 | 103.0 | 106.3 | 116.0 | 87 | 89 | 100* |
| 9 | 110.5 | 113.2 | 120.3 | 89 | 92 | 80 |
| 10 | 103.3 | 103.6 | 108.5 | 91 | 95 | 17 |
| 11 | 105.5 | 108.3 | 112.9 | 91 | 93 | 57 |
| 12 | 113.1 | 113.1 | 119.0 | 90 | 95 | 40 |
| 13 | 118.8 | 115.1 | 124.3 | 88 | 90 | 80 |
| 14 | 110.3 | 113.8 | 120.1 | 90 | 92 | 100 |
| 15 | 103.9 | 106.2 | 116.2 | 87 | 89 | 100 |
| Total Average | | | | 89 | 93 | 68 |

*Based on small number of tests.

ILLUSTRATION OF THEORETICAL MINIMUM ACCEPTABLE DENSITIES FOR TWO SOILS UNDER THE PRESENT FIELD COMPACTION CONTROL METHOD

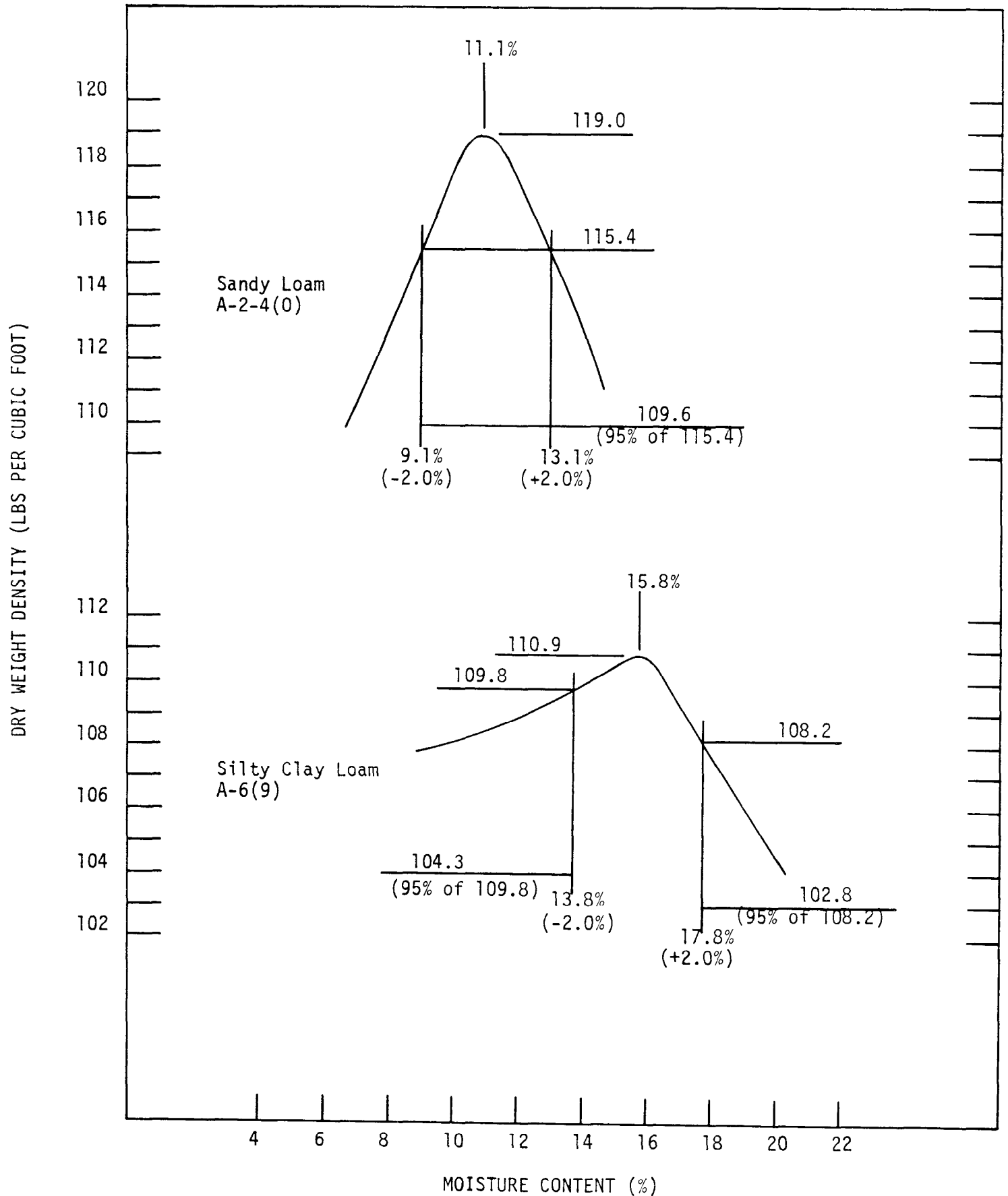

FIGURE 6

Figure 6 illustrates these possibilities. The density for the sandy loam soil at two percent dry and/or wet of optimum is 115.4 pounds per cubic foot or 97 percent of curve maximum density; thus, 109.6 pounds per cubic foot (95 percent of 115.4) would be the minimum acceptable value. This would mean that 92 percent, based on the laboratory curve maximum, could be accepted for the sandy loam soil under the present field compaction control method. Also, as shown for the silty clay loam soil, 104.3 and 102.8 pounds per cubic foot or 94 and 92.7 percent compaction respectively could be the accepted minimum values.

To require compaction at a designated moisture content without a tolerance on either side of this value would not be practical for in-place mixing. However, since optimum moisture content of any soil-cement mixture is an important function in obtaining maximum density, every effort should be made to compact the soil-cement mixture at or close to optimum moisture as possible. There is an alternate to in-place mixing of soil and water which, if used, can result in more uniformity in moisture content from station to station. This is the central plant or pugmill mixing of soil and water.

From the data in Figure 6 it can also be seen where the present method of project density control allows different maximum densities to be required for the same soil types on the same project. This in turn may result in a wide variance of compressive strengths within the base course.

The importance of the density of a soil upon its strength is well documented. By the present specifications, the probability exists that the density obtained in the field will be less than the 95 percent of maximum density of a design moisture-density curve. Data substantiating this viewpoint is presented in Table 3. The "Ratio of Present Requirements versus Laboratory Design Density" shows the percent compaction requirements as based upon the maximum density of the laboratory design curve. "Actual percent compaction based upon Laboratory Design Density" presents the percent compaction of the actual field densities using the laboratory design curve's maximum density as the maximum density. As shown, the present method of controlling density has actually lowered the density requirements and density achievement based upon the laboratory design curve. Sixty-eight percent of the tests of the research data, which met present specification requirements, do not meet 95 percent compaction requirements based upon the laboratory design curve.

Figure 7 shows a typical relationship between density and compressive strength. It is quite apparent that there is a significant strength increase between 90 percent and 105 percent compaction, which is the range of values occurring most frequently in the field. It appears that a compaction difference between 90 percent and 100 percent affects strength similarly to a cement content of two percent. In addition, according to Marshall(5), "A relationship existed between density and cracking, the higher density resulting in less shrinkage."

On some projects, the density closely approached 100 percent laboratory compaction with little difficulty, yet on other projects difficulty was encountered meeting the 95 percent compaction of the present two-proctor method. Naturally, the characteristics of a soil had a great effect upon the ease of densification; however, this does not appear to be the cause of the compaction difficulties. Those contractors having the least difficulty were most observant of the basic factors, good moisture control and the correct kind and size of equipment.

REPRESENTATIVE STRENGTH-COMPACTION CURVES

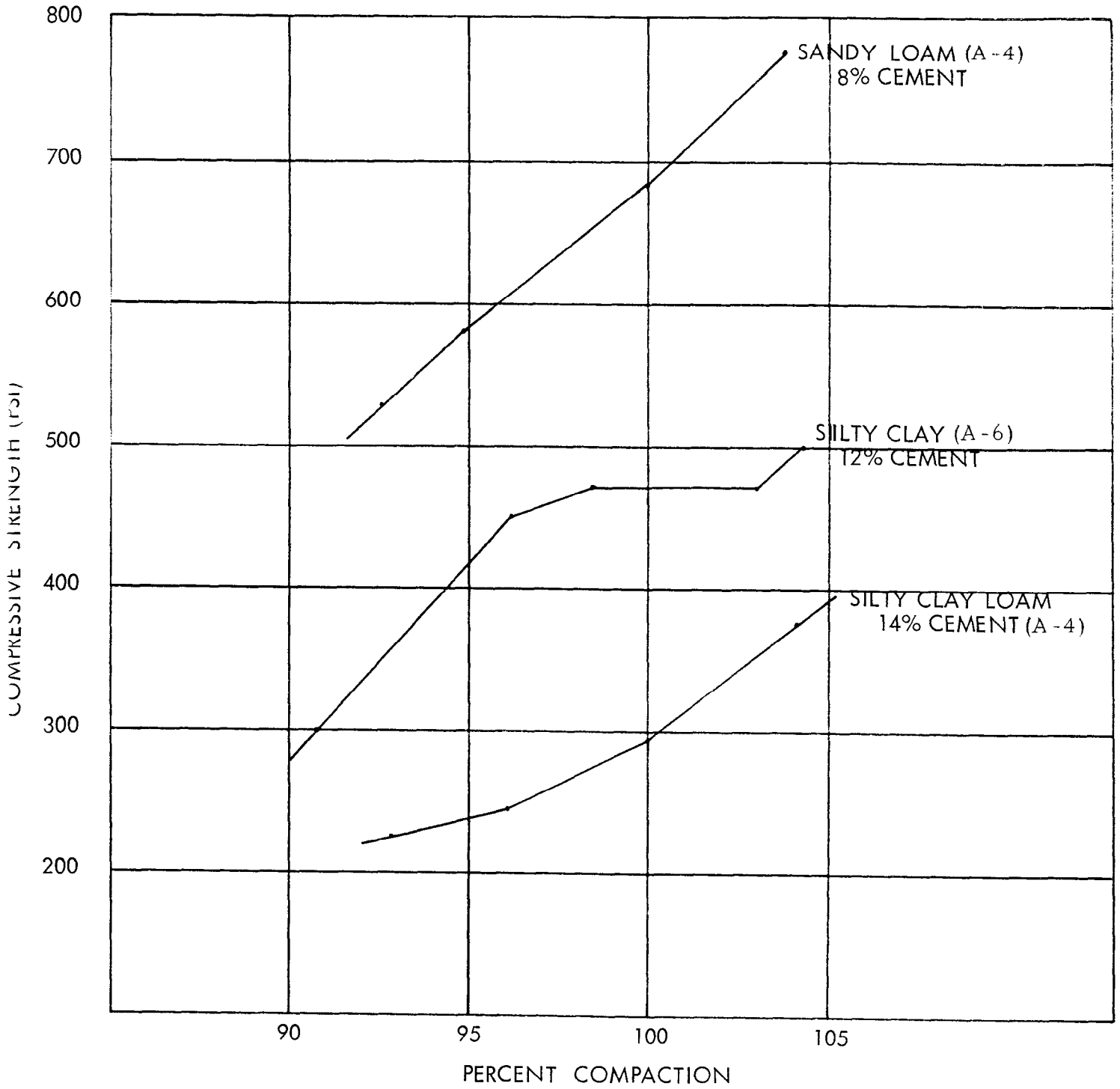

FIGURE 7

One problem common to soil-cement construction is that of a yielding sublayer. The deflection characteristics can be quite high for a raw soil compacted to 95 percent of standard proctor. Effort should be made to consider the compaction needs of the subgrade as well as the soil-cement base course.

Again, the pugmill method of soil-cement construction offers an advantage. A soil's moisture content greatly affects its deflection characteristics regardless of density. When the pugmill method is used, the layer beneath the soil-cement can be more closely observed and controlled prior to soil-cement placement; therefore, this layer is usually drier and thus offers a more rigid layer to roll against.

In any case, densification approaching 100 percent compaction is very difficult but, as Figure 7 illustrates, when successful very definite strength advantages are effected. Thus, achievement of optimum density is an important goal.

Present methods of density control under different methods of field construction, particularly moisture control, appear to increase the probability of density variation. In addition, a possible lessening of the obtainable maximum density appears to occur. Table 3 shows that with the present control method of using an average of two one-point proctors, 89 percent compaction can be accepted as 95 percent compaction. This directly results in a loss of strength, a fact well documented. According to Maclean and Lewis(6) "with increasing knowledge of factors affecting soil-cement strength it became apparent that small differences in moisture content and state of compaction from the specified requirements could have a great an effect on the properties of the soil-cement as a significant error in cement content. Also, a change in dry density of only one percent will produce a change in the strength of the stabilized materials of 10 percent." Another method of field compaction control appears desirable.

The following two methods are recommended for consideration in compaction control of soil-cement bases. The use of either one of the methods discussed below would be an improvement over that presently used and should result in a better product.

The first method would not require any significant changes in the present sampling and testing being performed by field and laboratory personnel. In fact, its adoption would reduce the amount of field testing now being performed by field personnel in density control of soil-cement bases.

At the present time untreated soil samples representing material from specified segments of the roadway are being obtained by field personnel and submitted to the laboratory for the determination of (1) suitability for use in soil-cement stabilization, (2) quantity of cement necessary for proper stabilization and, (3) optimum moisture of soil-cement mixture necessary for proper compaction. In the process of laboratory determination for optimum moisture, the maximum density of the mixture is also derived; however, it is not reported for use. It is recommended that this laboratory determined maximum density be reported along with the optimum moisture content and be used in density control for the appropriate roadway segments listed on the laboratory report.

This would eliminate the running of two one-point proctors by field personnel at the prevailing moisture content of the soil-cement mixture and should result in a better end product, as well as reducing the number of tests presently being performed by field personnel for density control.

OGIVE FOR DISTRIBUTION OF ACTUAL VERSUS THEORETICAL CEMENT CONTENTS

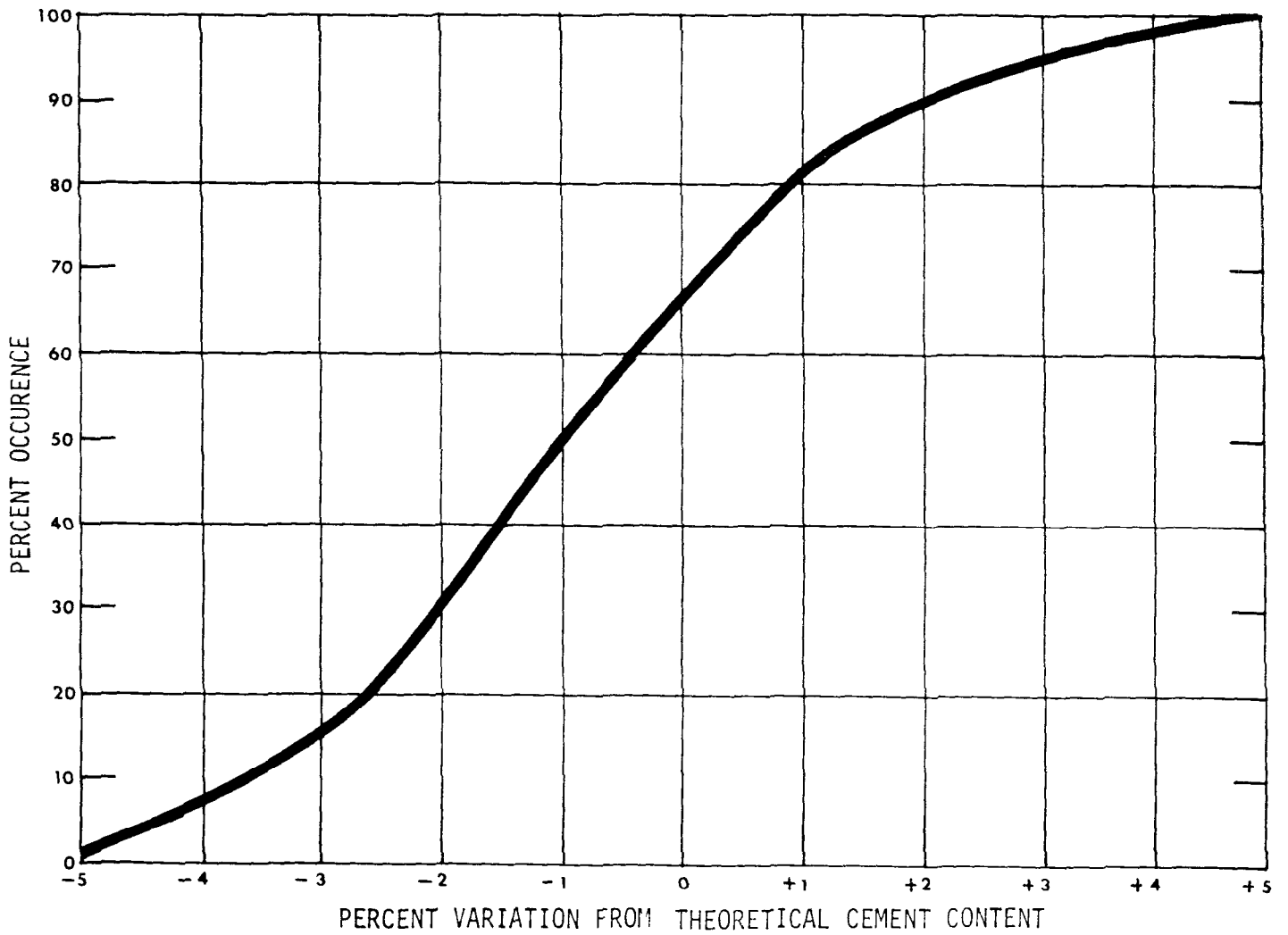

FIGURE 9

The second method consists of using the "control strip" concept for compaction control. The control strip concept for compaction control of base courses has been evaluated, Control Strip Research Study(7). Results of this study indicate a quick and flexible approach to the compaction control of bases which in the authors opinion, is superior to that presently used by the Department. Consideration by the Department should be given to implementing the findings in regard to soil-cement base construction.

Variability of Cement Content of Bases

Cement content of field molded specimens and of cores was determined on all fifteen projects. An attempt was made to correlate percent cement content of field specimens to strength, however, a definite trend could not be established due to the variation of specimen density and curing. These test results did show the wide variation of cement within the soil-cement bases as a result of in-place mixing. Figure 8 is a composite of all tests run (311 observations) and shows 49 and 25 percent of observations varying more than ± 1 and ± 2 percent cement, respectively, from the theoretical percentage. Further, the results in Figure 9 indicate that a greater percent of observations (51 percent) are less than the theoretical. Only 34 percent of observations were more than the theoretical, suggesting some loss in cement. Figures 10a, 10b and 11a illustrate this point by depicting actual loss of cement as a result of (1) spreading cement beyond limits of the base, (2) wind blown cement and, (3) excessive blading of soil-cement mixture after compaction to achieve proper grade. Also, the present methods of applying cement base may have to be examined closely in order to prevent a situation as depicted in Figure 10b from occurring in view of the present Federal and State interest in preventing air pollution.

Mixing efficiency appears to be somewhat less than desirable. The degree of uniformity of soil-cement blending is checked by visual means only at the present time. Figure 11b shows one case where very poor blending was accomplished. This situation occurred on several other projects wherein a layer of cement remained on the bottom of the cut after all blending was completed and the specified degree of pulverization was achieved. Thus the current practice of allowing a cement reduction of one percent when the pugmill method of mixing is used is well justified. In fact, when the pugmill mixing method is used consideration should be given to allowing a two percent cement reduction due to (1) more uniformity of distribution of cement (2) the improved moisture control, (3) the reduction of "waste" and (4) a more accurate check on quantity of cement being used.

The effects of multiple passes of soil stabilizers on the distribution of cement within the base material were investigated on four projects. This limited effort was initiated after preliminary results of cement content determinations began to show non-uniformity of cement distribution. At present, the Department's soil-cement base course specifications do not require a determination of cement content in mixed soil-cement; however, a pulverization requirement of a minimum of 70 percent by dry weight of material passing a No. 4 sieve is specified. Some soils (sand) require only one pass of stabilizer to achieve the pulverization requirement while others (silty clay loams with 12-14 PI) necessitate several passes. By obtaining samples from as near the same location as possible after each of several passes and by determining the cement content of each, it was hoped that some trend could be developed as to the effect of multiple passes on the distribution of cement within the base. The samples taken were divided into three parts (top-middle-bottom), and



CEMENT LOSS DUE TO SPREADING BEYOND LIMITS OF BASE
FIGURE 10a

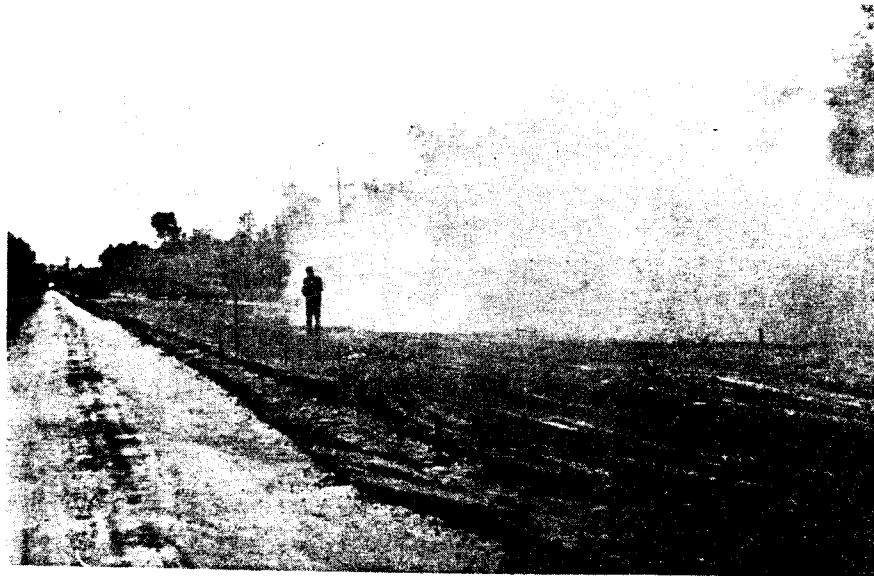

CEMENT LOSS DURING APPLICATION
FIGURE 10b

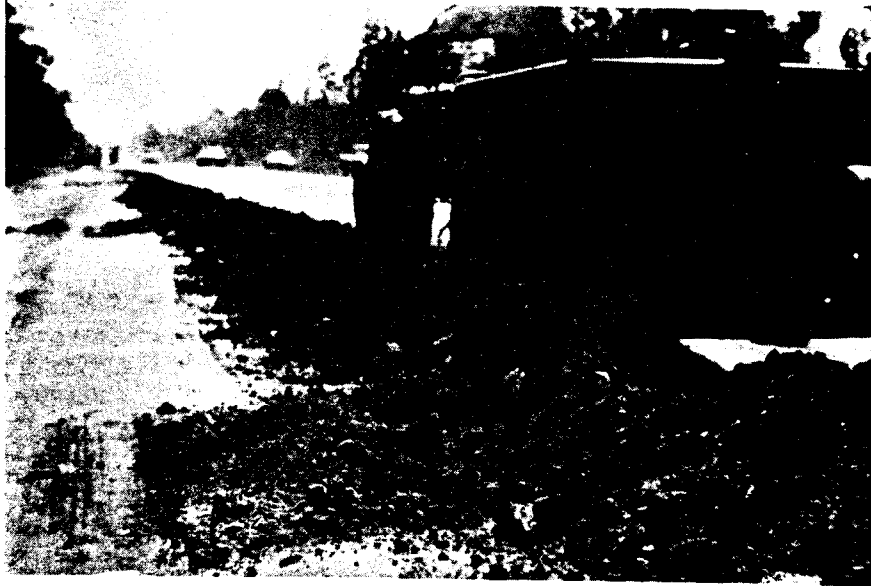

LOSS OF SOIL-CEMENT MIXTURE DURING FINAL BLADING
FIGURE 11a



NON-UNIFORM DISTRIBUTION OF CEMENT IN BASE
FIGURE 11b

percent of cement by dry weight determined for each part. At a later time cores were taken and also divided into three parts, and cement content determination performed for each part.

A statistical analysis was attempted on the data from the four projects, but no trends or conclusions could be observed. A much larger sampling number would be necessary for any trends to be developed. Typical results on two of the projects checked are listed in Tables 4A and 4B. Even though the results did not indicate an effect in cement distribution with continuous passes of a stabilizer, the results did show a variation of cement content from station to station on an individual project, as well as from the top portion of the base to the bottom.

TABLE 4a
CEMENT DISTRIBUTION

| Lab Number | Station Number and Location | Theo. Recom. % Cement by weight | Stabilizer Passes | | | | | | | | | | | | | | |
|------------|-----------------------------|---------------------------------|-------------------|------|------|--------|------|------|-------|------|------|--------|------|-----|-------|-----|-----|
| | | | First | | | Second | | | Third | | | Fourth | | | Fifth | | |
| | | | Top | Mid | Bot | Top | Mid | Bot | Top | Mid | Bot | Top | Mid | Bot | Top | Mid | Bot |
| SR 154 | 2272+50 ☒ | 7.3 | 7.8 | 8.8 | 8.2 | 7.7 | 8.4 | 8.9 | 6.3 | 5.9 | 5.9 | | | | | | |
| SR 155 | 2273+50 Left ☒ | 7.3 | 8.7 | 8.7 | 10.0 | 7.2 | 7.8 | 8.2 | 5.5 | 5.5 | 5.6 | 5.7 | 6.0 | 6.3 | | | |
| SR 156 | 2273+50 ☒ | 7.3 | 8.9 | 9.5 | 7.9 | 6.5 | 6.5 | 7.1 | 6.3 | 7.0 | 6.5 | 6.5 | 6.6 | 7.0 | | | |
| SR 157 | 2273+50 Right ☒ | 7.3 | 3.6 | 4.0 | 4.4 | 4.3 | 3.6 | 4.3 | 5.9 | 5.5 | 6.0 | | | | | | |
| SR 158 | 2274+50 ☒ | 7.3 | 5.9 | 4.9 | 5.6 | 5.5 | 5.1 | 5.5 | 6.2 | 6.6 | 6.7 | | | | | | |
| SR 159 | 2276+00 ☒ | 7.3 | 3.5 | 6.5 | 8.4 | 4.7 | 5.0 | 4.4 | 5.0 | 5.6 | 5.5 | 6.2 | 6.3 | 8.2 | | | |
| SR 160 | 2277+00 Left ☒ | 7.3 | 1.9 | 2.5 | 6.1 | 5.0 | 9.3 | 16.8 | 5.6 | 12.5 | 14.6 | 6.2 | 6.6 | 7.1 | 8.1 | 9.1 | 7.3 |
| SR 161 | 2277+00 ☒ | 7.3 | 2.8 | 7.5 | 23.4 | 16.1 | 16.8 | 14.8 | 12.2 | 11.4 | 14.1 | 9.5 | 10.6 | 9.4 | | | |
| SR 162 | 2277+00 Right ☒ | 7.3 | 3.0 | 6.3 | 6.3 | 3.5 | 4.5 | 5.5 | 3.6 | 4.7 | 3.6 | 5.6 | 6.0 | 6.2 | 4.9 | 5.5 | 4.7 |
| SR 163 | 2278+00 ☒ | 7.3 | 5.6 | 11.4 | 26.0 | 9.8 | 10.2 | 8.9 | 9.8 | 9.9 | 9.5 | 9.7 | 9.7 | 9.3 | | | |

TABLE 4b
CEMENT DISTRIBUTION

| Lab Number | Station Number and Location | Theo. Recom. % Cement by weight | Stabilizer Passes | | | | | | | | | Cores | | | | | |
|------------|-----------------------------|---------------------------------|-------------------|-----|-----|--------|------|------|-------|------|-----|-------|-----|-----|-------|-----|--|
| | | | First | | | Second | | | Third | | | 7 day | | | 7 day | | |
| | | | Top | Mid | Bot | Top | Mid | Bot | Top | Mid | Bot | Top | Mid | Bot | Total | | |
| SR 166 | 64+00 ☒ | 7.4 | 4.6 | 3.7 | 2.8 | 5.7 | 4.7 | 5.1 | 5.1 | 5.5 | 4.9 | 7.0 | 5.4 | 5.2 | | 5.1 | |
| SR 167 | 65+00 Left ☒ | 7.4 | 4.7 | 6.8 | 6.2 | 8.6 | 8.6 | 8.8 | 8.0 | 7.7 | 7.3 | 5.1 | 5.0 | 5.6 | | | |
| SR 168 | 65+00 ☒ | 7.4 | 4.6 | 5.9 | 5.2 | 4.9 | 6.3 | 6.8 | 6.1 | 5.9 | 7.7 | 5.6 | 5.5 | 5.9 | | 4.9 | |
| SR 169 | 65+00 Right ☒ | 7.4 | 7.2 | 7.8 | 6.0 | 5.5 | 7.0 | 7.3 | 8.2 | 8.2 | 8.3 | 7.6 | 8.4 | 8.3 | | | |
| SR 174 | 108+00 ☒ | 7.0 | 4.3 | 2.4 | 2.4 | 4.7 | 4.3 | 6.2 | 5.7 | 5.9 | 6.5 | 4.0 | 4.0 | 4.0 | | | |
| SR 175 | 109+00 Left ☒ | 7.0 | 3.0 | 4.7 | 5.2 | 10.0 | 11.0 | 12.2 | 10.1 | 10.3 | 9.4 | 7.5 | 7.3 | 5.2 | | | |
| SR 176 | 109+00 ☒ | 7.0 | 6.0 | 6.7 | 6.8 | 7.3 | 4.5 | 5.9 | 2.3 | 2.8 | 5.0 | 3.7 | 3.5 | 4.7 | | 3.7 | |
| SR 177 | 109+00 Right ☒ | 7.0 | 3.5 | 5.5 | 2.8 | 3.7 | 5.1 | 6.3 | 5.2 | 7.1 | 7.5 | 7.7 | 8.6 | 8.8 | | | |
| SR 178 | 110+00 ☒ | 7.0 | 4.5 | 4.9 | 4.6 | 5.6 | 5.0 | 5.5 | 5.5 | 5.0 | 4.6 | 6.8 | 4.4 | 3.9 | | | |

EVALUATION OF LOUISIANA SOILS USED FOR SOIL-CEMENT STABILIZATION

The object of this study was to evaluate reasonable compressive strength criteria for soil-cement base courses in Louisiana. At the present time, the basis of soil-cement base design in Louisiana is the AASHTO design coefficient of .15 which is 300 psi. Therefore, it would seem logical to specify 250 or 300 psi at 7 days in the laboratory determination of percent cement required for a specified soil, in order to obtain the designed base strength in the field.

The method of materials design in Louisiana for soil-cement base prior to initiation of this study was one based on durability, specifically the wet-dry test. Materials design is now based primarily on compressive strength criteria since the deterioration of soil-cement base courses prior to attainment of the design service life led to a re-evaluation of the design method. Deterioration was particularly evident where soil that contained high silt contents were used for stabilization.

During the course of this study a wide variety of soil types were encountered and tested for compressive strength. The test included field mixtures of soil-cement material as well as laboratory mixtures using the same soils. Two projects (Nos. 3 and 10) studied during the course of this research presented a good opportunity to check soils having high silt content, particularly since the same soils were used on both projects; the projects adjoined to each other, and the same contractor constructed both soil-cement bases.

As previously indicated, the cement percentage recommended for Project No. 3 was based on durability criteria and that for Project No. 10 on 300 psi laboratory compressive strength. A review of Figures 14 and 21 in the Appendix show the results obtained in each case. Strengths of cores at 28 days indicate 100 percent achievement of design strength at the stations checked for Project No. 10, and 25 percent at 28 days for Project No. 3. The compressive strength design test for Project No. 10 resulted in recommending 14 percent by volume of cement, however, test results of laboratory molded specimens and of cores (Tables 1 and 2) suggest that acceptable field strength of the base could have been achieved with 1 or 2 percent less cement. Eight percent cement by volume was used on Project No. 3 as determined by the durability test. The area in which these two projects are located have virtually no other soil types available for soil-cement than that used on these two projects. Because of poor base performance in the past coupled with difficulty in achieving 300 psi with high silt soils, the useability of these soils has been in doubt. However, based on study results it does appear that 300 psi can be achieved in the field with these silty soils within the limits of 8 to 14 percent cement presently used in Louisiana, provided the proper construction technique and controls are used.

One problem affecting the coring of bases common to not only silt or silty loam, but also to some soils classified as silty clay loam, was that of compaction planes or laminations in the top 3 to 4 inches of the base. This was particularly troublesome where a harrow was not used to breakup the planes created by the blading of the soil-cement mixture across the roadway while compacting with a pneumatic roller. Consideration should be given to modifying the specifications for compaction of soil-cement base so as to require the use of a sheepsfoot type roller, harrow or like device and a light pneumatic finishing roller for all soils containing 65 percent or more silt.

There are some Louisiana soils used in soil-cement stabilization that are sensitive to delayed compaction. This fact has been recognized for some time by field personnel especially in southwest Louisiana. The effects of delayed compaction of Louisiana soils has been well documented by Mr. Ara Arman in the "The Effect of Delayed Compaction on Stabilized Soil-Cement"(8). The soils react well with cement when tested by the standard laboratory design test, and the results of this study do indicate achievement of acceptable base strength with time. However, for several days after the blending of soil and cement in the field the base appears to be tender, that is, there appears to be a weak bonding of soil particles. Soils exhibiting this reaction were used on Projects Nos. 4, 5, 7, and 15. This weak bonding may be in part, the cause of low compressive strengths for some 7 and 28 day field molded-field cured specimens and 7 and 28 day cores. Table 5 show typical effects on density and strength for these type soils as a result of delayed compaction. These soils were (1) mixed with cement and water, (2) slaked for the indicated periods in plastic bags, (3) intermittently mixed until molded, (4) cured in moist room and (5) tested for compressive strength. The densities are of specimens at time of molding. Sample N204 and N132 are for soils for Project No. 15, and samples 3, 5, and 12 are soils from a soil-cement project in southwest Louisiana.

It does appear that good base strength with time can be achieved using this material (Project Nos. 7 and 15, Table 2) provided good construction techniques and proper equipment is used, and mixing and compaction is completed in less than two hours. It can be readily seen that if any prolonged mixing or compaction is allowed or if excessive construction traffic is encountered immediately after compaction, the quality of the base would be less than expected.

There are several alternates that can be used to counteract the effect of delayed compaction: (1) reduce the mixing and compaction time, (2) require additional compaction effort, (3) apply additional cement, and (4) add a cement set retarder. Of these, the reduction of time by plant mixing (in place of road mixing) and the addition of a set retarder is the most logical. Arman in his report "Counteraction of Detrimental Effects of Delayed Compaction"(9) has shown that Tri Methylol Propane, an admixture for plastic, will reduce the effects of delayed compaction on mixtures in the laboratory. It is recommended that the Department initiate field studies with TMP in order to determine if this reduction of detrimental effects can be achieved in the field and to establish economics of its use.

The blending of non-suitable (high PI) soils with suitable soils, usually sand or sandy soils, to produce material having acceptable physical characteristics for use in cement stabilized bases should be re-examined. Some blending of soils was done on Project No. 2, and as indicated on Table 1; the results of laboratory design tests were very good for the recommended cement percentage used on the projects. However, the results of field molded specimens cured in the laboratory and field do not reflect these results. Even though the pulverization requirement of 70 percent by dry weight of soil passing the No. 4 sieve was achieved, there were clay balls large enough in the mixture to affect the compressive strength of these molded specimens.

It is evident that the laboratory blending of these soils, results in a more uniform soil mixture than can ever be expected in the field for this material. Results of the various laboratory tests performed on the soils therefore portray a higher level of base quality than can actually be achieved. Therefore, it is recommended that the blending of non-suitable with suitable soils on the roadway not be permitted.

TABLE 5

EFFECTS OF DELAYED COMPACTION ON DENSITY AND COMPRESSIVE STRENGTH OF CERTAIN SOILS

| Sample No. | N204 | | N132 | | 3 | | | 5 | | | 12 | | |
|----------------------------|-------|-------|-------|-------|-------|-------|-------|-------|-------|-------|-------|-------|-------|
| Delay Period (hours) | 0 | 6 | 0 | 6 | 0 | 2 | 3 | 0 | 4 | 6 | 0 | 4 | 6 |
| Dry Unit Wt. (lbs./cu.ft.) | 117.5 | 101.2 | 115.6 | 105.2 | 112.0 | 105.2 | 103.2 | 113.5 | 106.6 | 104.0 | 115.3 | 103.1 | 101.3 |
| Molded M.C. (%) | 11.8 | 11.5 | 12.1 | 11.5 | 15.7 | 15.6 | 15.6 | 14.5 | 14.2 | 14.4 | 13.6 | 13.5 | 13.6 |
| P.S.I. (7 day Cure) | 441 | 175 | 517 | 288 | 219 | 184 | 156 | 221 | 172 | 145 | 325 | 183 | 171 |

VARIABILITY OF LABORATORY DESIGN

Statistical Analysis of Laboratory Design

Under the existing procedure at the commencement of the study, three specimens were molded for each of the three different cements, with a two percent step between each of three cement contents. Due to specimen damage or poor strength determination, a minimum of two specimens for each of the cement contents was acceptable. After seven days cure, the specimens were broken; the results plotted, and the cement content necessary to stabilize the soil to 300 psi at 7 days was found. Thus six specimens could be used to establish this value.

In the process of obtaining the laboratory data, it was discovered that the soil-cement laboratory design procedure, based upon compressive strength, exhibited a greater amount of variability than previously acknowledged. At first, procedural errors were blamed, but repeated tests under strictly controlled circumstances confirmed the degree of variability. Table 6 shows that a difference of 100 psi between identical specimens could occur. Therefore because of the possible wide variation in specimen compressive strength an investigation of the reliability of the test procedure when performed by any State Laboratory was initiated.

In order to evaluate the performance of test procedure(s), interlaboratory or round robin tests are frequently employed. Test procedures are used to ascertain whether a product meets the specification set down for the product, or they may be performed for design purposes as has been the purpose here. Regardless of the intended purpose, the information desired is whether the test procedure as set forth is capable of yielding acceptable agreement among results from different laboratories.

Table 7 lists data generated by the first phase of cooperative testing. The test procedure is generally performed on a routine basis for cement content determination by the Materials Laboratory only. The Research Laboratory, although not directly involved in the design determination is well versed with the test procedure. The nine district laboratories have very little to do with this facet of testing. Selection of laboratories for this testing program was therefore confined to the Materials Laboratory, Research Laboratory and one District Laboratory, the District Laboratory which was selected at random.

Table 8 lists the computed statistical parameters for the group of data. The variation for each series of soil-cement data is expressed by the standard deviation σ . In order to make the comparison of variability for various laboratory/soil/cement series data, relative measure of this dispersion is also indicated in the table as coefficient of variation which is the ratio of standard deviation to the mean of a given series. This measure is particularly useful when widely differing means (\bar{x} 's) are encountered.

It was pointed out in the preceding paragraph that the district laboratories are not as familiar with the test procedure as the other two laboratories. This is evident from the magnitude of the coefficient of variation which is considerably higher than that indicated by the Research or the Materials Laboratories. Furthermore, the magnitude of this variation is considerably higher than could be expected due to chance alone. Therefore, an effort was made to isolate the assignable causes of variation before starting the second round of cooperative testing.

TABLE 6
 COMPRESSIVE STRENGTH RESULTS OBTAINED BY TWO LABORATORIES
 (PHASE I)

| Soil Types | Soils Research Laboratory | | District Laboratory | |
|------------------------|---------------------------|-----|---------------------|-----|
| Sandy Clay Loam A-4(3) | | | | |
| 8% Cement | 394 | 376 | 245 | 206 |
| 10% Cement | 470 | 443 | 270 | 288 |
| 12% Cement | 520 | 519 | 373 | 348 |
| 14% Cement | 563 | 566 | 423 | 430 |
| Loam A-4(4) | | | | |
| 8% Cement | 445 | 425 | 202 | 288 |
| 10% Cement | 541 | 610 | 440 | 373 |
| 12% Cement | 573 | 648 | 536 | 444 |
| 14% Cement | 641 | 645 | 539 | 543 |

TABLE 7
 COMPRESSIVE STRENGTH RESULTS OBTAINED BY THREE LABORATORIES
 (PHASE II)

| Soil Type | Soils Research Laboratory | | | | | | | | District 07 Laboratory | | | | | | | | Materials Laboratory | | | | | | | |
|----------------------------|---------------------------|-----|-----|-----|-----|-----|-----|-----|------------------------|------|-----|-----|-----|-----|-----|-----|----------------------|-----|-----|-----|-----|-----|-----|-----|
| Sandy Loam A-2-4(0) | | | | | | | | | | | | | | | | | | | | | | | | |
| 6% Cement | 282 | 305 | 302 | 266 | 287 | 294 | | | 247 | 262 | 211 | 247 | 266 | 270 | 283 | 247 | 240 | 219 | 218 | 219 | 208 | 215 | 224 | 217 |
| 8% Cement | 420 | 437 | 423 | 441 | 381 | 382 | | | 337 | 349 | 276 | 357 | 325 | 365 | 305 | 345 | 313 | 340 | 314 | 329 | 309 | 373 | 398 | 378 |
| 10% Cement | 571 | 563 | 548 | 524 | 561 | 525 | | | 480 | 535 | 480 | 452 | 507 | 483 | 511 | 495 | 461 | 407 | 445 | 422 | 433 | 432 | 459 | 454 |
| 12% Cement | 672 | 696 | 767 | 702 | 645 | 589 | | | 594 | 527 | 674 | 634 | 741 | 674 | 638 | 694 | 723 | 704 | 698 | 760 | 654 | 720 | 670 | 657 |
| 14% Cement | 812 | 732 | 684 | 756 | 796 | 844 | 844 | 848 | 575 | 1050 | 888 | 900 | 884 | 927 | 931 | 820 | 761 | 785 | 794 | 772 | 856 | 926 | 884 | 865 |
| Clay Loam A-6(11) | | | | | | | | | | | | | | | | | | | | | | | | |
| 6% Cement | 271 | 266 | 272 | 285 | 303 | 268 | 282 | 275 | 186 | 246 | 246 | 222 | 206 | 269 | 226 | 250 | 182 | 196 | 211 | 197 | 210 | 204 | 235 | 213 |
| 8% Cement | 366 | 353 | 321 | 374 | 325 | 364 | 310 | 342 | 222 | 266 | 297 | 281 | 321 | 313 | 281 | 289 | 277 | 272 | 264 | 270 | 300 | 286 | 299 | 265 |
| 10% Cement | 384 | 412 | 410 | 411 | 382 | 403 | 373 | 411 | 424 | 412 | 321 | 289 | 396 | 329 | 297 | 329 | 303 | 318 | 334 | 297 | 306 | 292 | 313 | 311 |
| 12% Cement | 408 | 429 | 475 | 477 | 436 | 457 | 449 | 429 | 551 | 487 | 491 | 357 | 507 | 488 | 495 | 460 | 385 | 392 | 320 | 363 | 345 | 356 | 343 | 348 |
| 14% Cement | 500 | 497 | 501 | 497 | 508 | 599 | 610 | 573 | 507 | 468 | 416 | 460 | 487 | 487 | 511 | 420 | 404 | 311 | 404 | 407 | 405 | 404 | 424 | 438 |
| Silty Loam A-4(8) | | | | | | | | | | | | | | | | | | | | | | | | |
| 8% Cement | 273 | 267 | 282 | 275 | 298 | 302 | 263 | 267 | 262 | 202 | 198 | 194 | 162 | 198 | 230 | 218 | 228 | 207 | 185 | 210 | 215 | 210 | 218 | 190 |
| 10% Cement | 302 | 320 | 326 | 319 | 323 | 322 | 308 | 307 | 262 | 281 | 266 | 321 | 333 | 289 | 277 | 285 | 212 | 220 | 210 | 223 | 218 | 224 | 224 | 226 |
| 12% Cement | 364 | 375 | 363 | 395 | 403 | 394 | 401 | 403 | 305 | 345 | 309 | 293 | 289 | 289 | 269 | 333 | 309 | 326 | 284 | 294 | 318 | 300 | 320 | 278 |
| 14% Cement | 438 | 419 | 479 | 415 | 454 | 438 | 393 | 407 | 305 | 400 | 361 | 337 | 349 | 384 | 357 | 365 | 330 | 367 | 333 | 277 | 330 | 365 | 329 | 356 |
| 16% Cement | 470 | 457 | 485 | 463 | 462 | 464 | 475 | 449 | 396 | 432 | 468 | 373 | 384 | 396 | 483 | 487 | 432 | 426 | 425 | 390 | 394 | 423 | 399 | 406 |

TABLE 8
STATISTICAL EVALUATION OF TRI-LAB DATA
(PHASE II)

| Soil | Cement Content | \bar{X} , Mean | | | σ , Standard Deviation | | | γ , Coefficient of Variation | | | R^2 | b | a | |
|------|--------------------------------|------------------|-----------|----------|-------------------------------|-----------|----------|-------------------------------------|-----------|----------|--------|--------|---------|--------|
| | | Research | Materials | Dist. 07 | Research | Materials | Dist. 07 | Research | Materials | Dist. 07 | | | | |
| A | 6 | 289.33 | 220.00 | 254.13 | 14.36 | 9.26 | 21.72 | 0.05 | 0.04 | 0.08 | | | | |
| | 8 | 414.00 | 344.25 | 344.88 | 26.41 | 34.31 | 22.63 | 0.06 | 0.10 | 0.07 | | | | |
| | 10 | 548.67 | 439.13 | 492.88 | 20.13 | 19.06 | 25.09 | 0.04 | 0.04 | 0.05 | | | | |
| | 12 | 678.33 | 698.25 | 647.00 | 59.80 | 36.62 | 65.42 | 0.09 | 0.05 | 0.10 | | | | |
| | 14 | 789.25 | 830.78 | 871.88 | 60.29 | 60.33 | 135.43 | 0.08 | 0.07 | 0.16 | | | | |
| | 16 | | | | | | | | | | | | | |
| | Research Materials District 07 | | | | | | | | | | | 0.9988 | 63.85 | -95.30 |
| | | | | | | | | | | | 0.9739 | 78.70 | -280.80 | |
| | | | | | | | | | | | 0.9769 | 76.90 | -246.80 | |
| B | 6 | 211.63 | - | - | 10.41 | - | - | 0.05 | - | - | | | | |
| | 8 | 278.38 | 207.88 | 208.00 | 14.60 | 14.20 | 29.39 | 0.05 | 0.07 | 0.14 | | | | |
| | 10 | 315.88 | 219.63 | 289.25 | 8.87 | 5.90 | 25.19 | 0.03 | 0.03 | 0.09 | | | | |
| | 12 | 387.25 | 303.63 | 304.00 | 17.19 | 17.53 | 24.91 | 0.04 | 0.06 | 0.08 | | | | |
| | 14 | 442.88 | 335.88 | 357.25 | 30.76 | 28.82 | 28.85 | 0.07 | 0.09 | 0.08 | | | | |
| | 16 | 465.63 | 411.88 | 427.38 | 11.06 | 16.47 | 46.49 | 0.02 | 0.04 | 0.11 | | | | |
| | Research Materials District 07 | | | | | | | | | | | 0.9867 | 25.20 | 71.60 |
| | | | | | | | | | | | 0.9587 | 26.20 | -18.40 | |
| | | | | | | | | | | | 0.9649 | 25.30 | 13.40 | |
| C | 6 | 277.75 | 206.00 | 231.38 | 12.12 | 15.55 | 26.75 | 0.04 | 0.08 | 0.12 | | | | |
| | 8 | 344.38 | 279.13 | 283.75 | 23.65 | 14.37 | 30.65 | 0.07 | 0.05 | 0.11 | | | | |
| | 10 | 398.25 | 309.25 | 349.63 | 15.94 | 13.11 | 53.03 | 0.04 | 0.04 | 0.15 | | | | |
| | 12 | 445.00 | 356.50 | 479.55 | 24.04 | 23.40 | 55.75 | 0.05 | 0.07 | 0.12 | | | | |
| | 14 | 535.63 | 399.65 | 469.50 | 49.51 | 37.40 | 36.15 | 0.09 | 0.09 | 0.08 | | | | |
| | Research Materials District 07 | | | | | | | | | | | 0.9876 | 30.85 | 91.70 |
| | | | | | | | | | | | | 0.9831 | 23.30 | 77.20 |
| | | | | | | | | | | | 0.9276 | 33.70 | 26.00 | |

It was found that the temperature of the three components - soil, cement and water varied widely for any one laboratory and among the three laboratories. The soil and the cement were stored in some instances, in areas where temperatures were not controlled. That is, the temperature of the storage area fluctuated with the season - high in summer and low in winter. This could result in the use of hot cement and soil for some specimens when molded in the summer.

Tap water was used in the molding of all specimens. This in itself did not seem to cause any problems, however, the temperature of one laboratory's tap water was close to 100 degrees (F.) as a result of its pipes being adjacent to the buildings steam lines.

A check of specimens immediately after molding revealed many dry particles. The existing procedure required the full incorporation of water and cement immediately prior to mixing. The soil particles did not adequately absorb the water immediately, causing density variations. Later, during the curing process, these soil particles possibly compete with the cement for the available water.

Another possible cause of variation could be due to the cement itself. The cement used by the three laboratories came from different sources. Seven day compressive strength (AASHTO T-106) varied from 2100 psi to 4500 psi.

To alleviate these possible causes of variation the following steps were taken:

- (1) Each component in the fabrication of soil-cement specimens was brought to the same temperature ($75^{\circ}\text{F} \pm 5^{\circ}$) prior to molding the specimens.
- (2) Water was added to the raw soils and the mixture was allowed to slake overnight before addition of cement.
- (3) Cement from the same manufactured batch was used.
- (4) The time involved in fabrication of specimens was held uniform.

The specimens densities and moisture contents were closely controlled between the three laboratories by using the same density and optimum moisture for specimen design for each material tested.

On the basis of standardization, a second set of soil samples were distributed to the same laboratories. The soils belonged to the same classification group. The same experimental design as the first one was used in this phase with the exception that replicates were reduced from 8 to 4. The improvement in the variability as indicated by the data in Table 10 is clearly evident. With the exception of two series of data, the relative dispersion was 0.10 or 10 percent or less. Overall there was a decrease in the variability of the test procedure as a result of standardization.

In order to study the effect of different levels of the factors on the overall variance, an Analysis of Variance technique was used to isolate the components of variance. For analysis purpose the factors in the design were considered as mixed-model combination factors. The laboratories and cement content were considered fixed effect and the soils factor as random effect. Table 11 is the outcome of the analysis of variance procedure. The sources of variation were broken down into three main factors, first order interaction, second order interaction

TABLE 9
 COMPRESSIVE STRENGTH RESULTS OBTAINED BY THREE LABORATORIES
 (PHASE III)

| Soil Type | Soils Research Laboratory | | | | Materials Laboratory | | | | District Laboratory | | | |
|-------------------|---------------------------|-----|-----|-----|----------------------|-----|-----|-----|---------------------|-----|-----|-----|
| Sandy-Loam A-4(2) | | | | | | | | | | | | |
| 6% Cement | 330 | 361 | 349 | 372 | 238 | 248 | 236 | 227 | 237 | 229 | 215 | 195 |
| 8% Cement | 427 | 481 | 462 | 536 | 279 | 310 | 307 | 313 | 280 | 285 | 282 | 280 |
| 10% Cement | 540 | 577 | 564 | 471 | 344 | 345 | 341 | 353 | 309 | 301 | 333 | 345 |
| 12% Cement | 632 | 684 | 644 | 657 | 458 | 451 | 403 | 471 | 408 | 438 | 475 | 440 |
| 14% Cement | 832 | 883 | 777 | 789 | 495 | 507 | 509 | 516 | 553 | 628 | 501 | 545 |
| 16% Cement | 871 | 923 | 915 | 887 | 572 | 558 | 584 | 514 | 540 | 553 | 563 | 505 |
| Clay Loam A-6(9) | | | | | | | | | | | | |
| 6% Cement | 248 | 277 | 241 | 251 | 144 | 150 | 159 | 146 | 181 | 185 | 174 | 185 |
| 8% Cement | 322 | 333 | 343 | 334 | 185 | 177 | 204 | 203 | 212 | 245 | 211 | 214 |
| 10% Cement | 340 | 362 | 379 | 357 | 230 | 218 | 209 | 223 | 222 | 226 | 216 | 244 |
| 12% Cement | 371 | 411 | 403 | 379 | 250 | 227 | 214 | 247 | 201 | 232 | 230 | 236 |
| 14% Cement | 465 | 446 | 430 | 421 | 269 | 289 | 270 | 278 | 255 | 296 | 269 | 275 |
| 16% Cement | 513 | 510 | 497 | 520 | 249 | 270 | 294 | 290 | 351 | 286 | 332 | 322 |
| Silty Loam A-4(8) | | | | | | | | | | | | |
| 6% Cement | 187 | 187 | 198 | 186 | 145 | 131 | 136 | 135 | 144 | 159 | 141 | 119 |
| 8% Cement | 221 | 186 | 226 | 223 | 153 | 167 | 165 | 184 | 166 | 176 | 151 | 145 |
| 10% Cement | 269 | 294 | 263 | 260 | 198 | 186 | 198 | 216 | 166 | 161 | 231 | 224 |
| 12% Cement | 310 | 333 | 332 | 341 | 230 | 206 | 211 | 224 | 222 | 211 | 222 | 211 |
| 14% Cement | 420 | 396 | 404 | 392 | 284 | 260 | 257 | 259 | 285 | 279 | 275 | 225 |
| 16% Cement | 440 | 415 | 442 | 422 | 312 | 289 | 309 | 330 | 287 | 285 | 282 | 315 |

TABLE 10
 STATISTICAL EVALUATION OF TRI-LAB DATA
 (PHASE III)

| Soil | Cement Content | \bar{x} , Mean | | | σ , Standard Deviation | | | γ , Coefficient of Variation | | | R^2 | b | a |
|------------|-----------------------------------|------------------|-----------|----------|-------------------------------|-----------|----------|-------------------------------------|-----------|----------|-------|---|---|
| | | Research | Materials | District | Research | Materials | District | Research | Materials | District | | | |
| Sandy Loam | 6 | 353.00 | 237.25 | 219.00 | 17.98 | 8.61 | 18.40 | .05 | .04 | .08 | | | |
| | 8 | 476.50 | 302.50 | 281.75 | 45.54 | 15.69 | 2.36 | .10 | .05 | .01 | | | |
| | 10 | 538.00 | 345.75 | 322.00 | 47.22 | 5.12 | 20.49 | .09 | .01 | .06 | | | |
| | 12 | 654.25 | 445.75 | 440.25 | 22.31 | 29.68 | 27.40 | .03 | .07 | .09 | | | |
| | 14 | 820.25 | 506.75 | 556.75 | 48.04 | 8.83 | 52.71 | .06 | .02 | .09 | | | |
| | 16 | 899.00 | 557.00 | 540.25 | 24.22 | 30.60 | 25.32 | .03 | .05 | .05 | | | |
| | Research Materials District | | | | | | | | | | | | |
| Clay Loam | 6 | 254.25 | 149.75 | 181.25 | 15.73 | 6.65 | 5.19 | .06 | .04 | .03 | | | |
| | 8 | 333.00 | 192.25 | 220.50 | 8.60 | 13.40 | 16.38 | .03 | .07 | .07 | | | |
| | 10 | 359.50 | 220.00 | 227.00 | 16.10 | 8.83 | 12.06 | .04 | .04 | .05 | | | |
| | 12 | 391.00 | 234.50 | 224.75 | 19.04 | 17.06 | 16.03 | .06 | .05 | .07 | | | |
| | 14 | 440.50 | 276.50 | 273.75 | 19.33 | 9.25 | 17.04 | .04 | .03 | .06 | | | |
| | 16 | 510.00 | 275.50 | 322.75 | 4.81 | 21.13 | 27.29 | .01 | .08 | .08 | | | |
| | Research Materials District | | | | | | | | | | | | |
| Silty Loam | 6 | 189.50 | 136.75 | 140.75 | 5.67 | 5.91 | 16.50 | .03 | .04 | .12 | | | |
| | 8 | 214.00 | 167.00 | 159.50 | 18.78 | 12.83 | 14.11 | .09 | .08 | .09 | | | |
| | 10 | 271.50 | 199.50 | 195.50 | 15.46 | 12.37 | 37.12 | .06 | .06 | .19 | | | |
| | 12 | 329.00 | 218.00 | 216.50 | 13.29 | 11.52 | 6.35 | .04 | .05 | .03 | | | |
| | 14 | 403.00 | 265.00 | 266.00 | 12.38 | 12.73 | 27.64 | .03 | .05 | .10 | | | |
| | 16 | 429.75 | 310.00 | 292.25 | 13.33 | 16.79 | 15.31 | .03 | .05 | .05 | | | |
| | Research Materials District | | | | | | | | | | | | |

TABLE 11

| Analysis of Variance Table | | | | |
|-----------------------------------|-------------------------------------|---------------|---------------------------------|---|
| Source of Variable | Sum of Square | DF | Mean of Square | Estimated Variance |
| Lab (L) Soil (S) Cement (C) | 1,166,969 2,136,428 1,685,994 | 2 2 5 | 583,484 1,068,214 337,198 | $\sigma^2 + k_s \sigma^2(L) + k_{sc} \sigma^2(L)$ $\sigma^2 + k_l \sigma^2(SC) + k_{lc} \sigma^2(S)$ $\sigma^2 + k_l \sigma^2(C)$ |
| L x S L x C S x C | 151,046 109,267 342,709 | 4 10 10 | 37,761 10,927 34,271 | $\sigma^2 + k \sigma^2(LSC) + k_c \sigma^2(LS)$ $\sigma^2 + k_s \sigma^2(LC)$ $\sigma^2 + k_l \sigma^2(SC)$ |
| L x S x C | 32,473 | 20 | 1,624 | $\sigma^2 + k \sigma^2(LSC)$ |
| Error | 487,980 | 162 | 3,012 | σ^2 |
| TOTAL | 6,112,866 | 215 | 28,432 | - |

and error terms components. The variance estimates for each of the mean square terms are also shown in the last column of the table. The test for significance (F-test) can be made from these variance estimated terms. All the F values except the second order interaction terms are significant.

The largest source of variation in result is between cement contents. However, the laboratory factor shows greater contribution to the variance than the soil factor. The error mean square of 3012.22 indicates a standard deviation for a single measurement of about 55 psi.

The effect of soils sample stored for some period of time and then mixed for cement content determination was another aspect studied during the study period.

The experiment consisted of soils samples being prepared and divided into two equal parts by the Soils Research Unit; one part for testing by the Soils Research Laboratory and the other part for testing by the District Laboratory. Soil-cement design tests were performed for each soil type by both laboratories, with the District Laboratory retesting the same soils two weeks after completion of the first series. Both series (A and B) were treated as separate samples in all respects. The test procedure was as performed in the third phase with this exception: design data necessary for molding specimens was developed by each laboratory for its testing in each case.

In order to test whether there is a difference (due to time) in the strength property of specimens mixed and compacted at different times by the same laboratory, the statistical "t" test for unpaired data was run on the collected data shown in Table 14. The mean for each soil group data obtained at time A was compared to the mean of the same soil data obtained at time B. The calculated "t" values are indicated for each soil group in Table 16. With the exception of the soil group designated 117, none of the difference in the means showed to be significant at .05 level.

Investigation of Effect of Specimen Size and Molding Method

Preliminary tests suggested that the present standard proctor molding method as well as an inadequate length to diameter specimen ratio (less than 2:1) may be influential causes of inconsistency of compressive strength results. Shackel in "A Nuclear Method of Detecting Small Variations in Density with Soil Specimens" (10) states, "where samples are to be used for strength tests such as the triaxial test, non-uniformity within the specimens give a large scatter in the test results". Therefore the effect of the ratio of length to diameter of proctor size specimens was examined as a further effort to find a means of reducing the inconsistency of compressive strength results. This examination was attempted by comparing proctor size specimens molded using standard procedure and equipment to specimens molded and tested according to ASTM D-1632 and D-1633 procedures.

Theoretically, a specimen molded with a length to diameter ratio of 2:1 (ASTM D-1632 and D-1633) should result in a more uniform specimen than one molded in the standard proctor mold and using associated procedure; thus less inconsistency in compressive strength should occur. However, the results of a limited number of tests comparing the two methods did not substantiate this point, there was nearly

TABLE 12
COMPRESSIVE STRENGTH RESULTS OF BI-LAB STUDY

(PHASE IV)

| Soil Type | Cement Content | Soils Research | | | | District 07 Laboratory | | | |
|-------------------------------------|----------------|----------------|-----|-----|-----|------------------------|-----|-----|-----|
| SR-177 Silty Loam A-4(8) | 8 | 172 | 189 | 189 | 181 | 130 | 144 | 154 | -- |
| | 10 | 239 | 240 | 224 | 215 | 184 | 177 | 191 | 191 |
| | 12 | 261 | 266 | 275 | 293 | 241 | 237 | 204 | 241 |
| | 14 | 315 | 294 | 314 | 294 | 264 | 261 | 288 | 261 |
| SR-118 Silty Clay Loam A-6(9) | 8 | 113 | 124 | 121 | - | 124 | 124 | 150 | 154 |
| | 10 | 153 | 154 | 148 | 131 | 157 | 157 | 171 | 150 |
| | 12 | 156 | 169 | 172 | 173 | 194 | 191 | 197 | 181 |
| | 14 | 197 | 167 | 186 | 197 | 211 | 237 | 237 | 221 |
| SR-119 Silty Loam A-4(8) | 8 | 186 | 191 | 193 | 196 | 171 | 177 | 177 | 177 |
| | 10 | 226 | 231 | 237 | 232 | 207 | 217 | 211 | 204 |
| | 12 | 231 | 239 | 251 | 247 | 247 | 241 | 237 | 224 |
| | 14 | 279 | 290 | 285 | 285 | 267 | 254 | 237 | 244 |
| SR-122 Silty Loam A-4(8) | 8 | 177 | 282 | 271 | 279 | 204 | 234 | 231 | 261 |
| | 10 | 357 | 320 | 299 | 320 | 274 | 278 | 311 | 308 |
| | 12 | 387 | 417 | 414 | 399 | 318 | 385 | 334 | 368 |
| | 14 | 458 | 454 | 411 | 497 | 401 | 378 | 425 | 385 |
| SR-123 Silty Loam A-4(8) | 8 | 175 | 197 | 188 | 207 | 157 | 150 | 174 | 167 |
| | 10 | 226 | 228 | 221 | 218 | 134 | 207 | 207 | 207 |
| | 12 | 282 | 248 | 267 | 286 | 261 | 254 | 247 | 264 |
| | 14 | 352 | 337 | 393 | 331 | 284 | 334 | 351 | 294 |
| SR-131 Silty Loam A-4(8) | 8 | 220 | 213 | 199 | 146 | 157 | 140 | 184 | 187 |
| | 10 | 223 | 215 | 244 | 274 | 247 | 211 | 204 | 227 |
| | 12 | 322 | 395 | 355 | 337 | 281 | 294 | 301 | 314 |
| | 14 | 375 | 345 | 368 | 339 | 324 | 324 | 321 | 338 |

TABLE 13a
 STATISTICAL EVALUATION OF BI-LAB DATA
 (PHASE IV)

| Lab Number | Cement Content | \bar{x} , Mean | | σ , Standard Dev. | | γ , Coef. of Var. | | R ² | a | b |
|------------|----------------|------------------|----------|--------------------------|----------|--------------------------|----------|----------------|----------|---------|
| | | Research | Dist. 07 | Research | Dist. 07 | Research | Dist. 07 | | | |
| SR 117 | 8 | 182.75 | 142.66 | 8.09 | 12.05 | 0.04 | 0.08 | | | |
| | 10 | 229.50 | 185.75 | 12.12 | 6.70 | 0.05 | 0.04 | | | |
| | 12 | 273.75 | 230.75 | 14.08 | 17.93 | 0.06 | 0.08 | | | |
| | 14 | 304.25 | 268.50 | 11.84 | 13.07 | 0.04 | 0.05 | | | |
| | Research | | | | | | | 0.9914 | 22.7500 | 20.4375 |
| | Dist. 07 | | | | | | | 0.9987 | -25.4710 | 21.1260 |
| SR 118 | 8 | 119.33 | 138.00 | 5.68 | 16.24 | 0.05 | 0.12 | | | |
| | 10 | 146.50 | 158.75 | 10.66 | 8.80 | 0.07 | 0.06 | | | |
| | 12 | 167.50 | 190.75 | 7.85 | 6.94 | 0.05 | 0.02 | | | |
| | 14 | 186.75 | 226.50 | 14.15 | 12.79 | 0.08 | 0.04 | | | |
| | Research | | | | | | | 0.9933 | 32.2270 | 11.1630 |
| | Dist. 07 | | | | | | | 0.9868 | 14.8750 | 14.8750 |
| SR 119 | 8 | 191.50 | 175.50 | 4.20 | 3.00 | 0.02 | 0.02 | | | |
| | 10 | 231.50 | 209.75 | 4.50 | 5.61 | 0.02 | 0.02 | | | |
| | 12 | 242.00 | 237.25 | 8.86 | 9.74 | 0.04 | 0.04 | | | |
| | 14 | 284.75 | 250.50 | 4.50 | 13.02 | 0.02 | 0.05 | | | |
| | Research | | | | | | | 0.9562 | 77.800 | 14.5125 |
| | Dist. 07 | | | | | | | 0.9657 | 79.3750 | 12.6250 |

TABLE 13b
 STATISTICAL EVALUATION OF BI-LAB DATA
 (PHASE IV)

| Lab Number | Cement Content | \bar{x} , Mean | | σ , Standard Dev. | | γ , Coef. of Var. | | R^2 | a | b |
|------------|----------------|------------------|----------|--------------------------|----------|--------------------------|----------|--------|----------|---------|
| | | Research | Dist. 07 | Research | Dist. 07 | Research | Dist. 07 | | | |
| SR 123 | 8 | 191.75 | 162.00 | 13.59 | 10.61 | 0.07 | 0.07 | | | |
| | 10 | 223.25 | 188.75 | 4.57 | 36.50 | 0.02 | 0.19 | | | |
| | 12 | 270.75 | 256.50 | 17.23 | 7.59 | 0.03 | 0.03 | | | |
| | 14 | 353.25 | 315.75 | 27.93 | 31.92 | 0.06 | 0.10 | | | |
| | Research | | | | | | | 0.9549 | -32.8500 | 26.6000 |
| | Dist. 07 | | | | | | | 0.9731 | -60.2000 | 26.4500 |
| SR 131 | 8 | 194.50 | 167.00 | 33.49 | 22.49 | 0.17 | 0.13 | | | |
| | 10 | 239.00 | 222.25 | 26.34 | 19.10 | 0.11 | 0.09 | | | |
| | 12 | 352.25 | 297.50 | 31.53 | 13.77 | 0.09 | 0.05 | | | |
| | 14 | 356.75 | 326.75 | 17.44 | 7.63 | 0.05 | 0.02 | | | |
| | Research | | | | | | | 0.9011 | -44.3750 | 30.0000 |
| | Dist. 07 | | | | | | | 0.9754 | -51.6000 | 27.7250 |
| SR 122 | 8 | 252.25 | 232.50 | 50.38 | 23.50 | 0.20 | 0.10 | | | |
| | 10 | 324.00 | 292.75 | 24.12 | 19.44 | 0.07 | 0.07 | | | |
| | 12 | 404.25 | 351.25 | 13.93 | 30.67 | 0.03 | 0.09 | | | |
| | 14 | 455.00 | 397.25 | 35.16 | 20.85 | 0.08 | 0.05 | | | |
| | Research | | | | | | | 0.9923 | -19.8000 | 34.4250 |
| | Dist. 07 | | | | | | | 0.9963 | -14.4250 | 27.6375 |

TABLE 14
 COMPRESSIVE STRENGTH RESULTS OF DISTRICT LABORATORY
 TIME A vs TIME B

| Soil Type | Cement Content | District Laboratory A | | | | District Laboratory B | | | |
|-------------------------------------|----------------|-----------------------|-----|-----|-----|-----------------------|-----|-----|-----|
| | | | | | | | | | |
| SR-117 Silty Loam A-4(8) | 8 | 130 | 144 | 154 | - | 201 | 177 | 184 | 194 |
| | 10 | 184 | 177 | 191 | 191 | 244 | 241 | 257 | 247 |
| | 12 | 241 | 237 | 204 | 241 | 308 | 291 | 281 | 298 |
| | 14 | 264 | 261 | 288 | 261 | 338 | 344 | 344 | 348 |
| SR-118 Silty Clay Loam A-6(9) | 8 | 124 | 124 | 150 | 154 | 134 | 124 | 130 | 137 |
| | 10 | 157 | 157 | 171 | 150 | 157 | 163 | 160 | 193 |
| | 12 | 194 | 191 | 197 | 181 | 187 | 177 | 191 | 191 |
| | 14 | 211 | 237 | 237 | 221 | 201 | 204 | 207 | 204 |
| SR-119 Silty Loam A-4(8) | 8 | 171 | 177 | 177 | 177 | 154 | 140 | 164 | 167 |
| | 10 | 207 | 217 | 211 | 204 | 217 | 217 | 237 | 221 |
| | 12 | 247 | 241 | 237 | 224 | 278 | 281 | 264 | 271 |
| | 14 | 267 | 254 | 237 | 244 | 294 | 318 | 331 | 327 |
| SR-120 Sandy Loam A-2-4(0) | 8 | 227 | 227 | 227 | 207 | 177 | 187 | 174 | 171 |
| | 10 | 284 | 328 | 251 | 311 | 254 | 278 | 284 | 268 |
| | 12 | 341 | 381 | 385 | 401 | 338 | 364 | 271 | 368 |
| | 14 | 465 | 478 | 461 | 478 | 455 | 431 | 465 | 488 |
| SR-121 Silty Loam A-4(8) | 8 | 201 | 234 | 201 | 231 | 221 | 201 | 227 | 217 |
| | 10 | 247 | 261 | 247 | 251 | 251 | 251 | 234 | 264 |
| | 12 | 321 | 301 | 301 | 338 | 368 | 348 | 371 | 348 |
| | 14 | 375 | 379 | 375 | 408 | 405 | 405 | 405 | 418 |
| SR-122 Silty Loam A-4(8) | 8 | 204 | 234 | 231 | 261 | 177 | 207 | 231 | 241 |
| | 10 | 274 | 278 | 311 | 308 | 288 | 284 | 298 | 304 |
| | 12 | 318 | 385 | 334 | 368 | 361 | 361 | 371 | 344 |
| | 14 | 401 | 378 | 425 | 385 | 398 | 375 | 361 | 378 |
| SR-123 Silty Loam A-4(8) | 8 | 157 | 150 | 174 | 167 | 171 | 167 | 157 | 167 |
| | 10 | 134 | 207 | 207 | 207 | 204 | 194 | 207 | 207 |
| | 12 | 261 | 254 | 247 | 264 | 241 | 237 | 227 | 241 |
| | 14 | 284 | 334 | 351 | 294 | 284 | 288 | 278 | 294 |
| SR-131 Silty Loam A-4(8) | 8 | 157 | 140 | 184 | 187 | 167 | 167 | 157 | 157 |
| | 10 | 247 | 211 | 204 | 227 | 211 | 227 | 211 | 217 |
| | 12 | 281 | 294 | 301 | 314 | 284 | 294 | 271 | 298 |
| | 14 | 324 | 324 | 321 | 338 | 311 | 334 | 324 | 308 |

TABLE 15a
 STATISTICAL EVALUATION OF DISTRICT LABORATORY DATA
 TIME A vs TIME B

| Lab Number | Cement Content | \bar{x} , Mean | | σ , Standard Dev. | | γ , Coef. of Var. | | R^2 | a | b |
|------------|----------------|------------------|--------|--------------------------|-------|--------------------------|------|--------|----------|---------|
| | | A | B | A | B | A | B | | | |
| SR 117 | 8 | 142.66 | 189.00 | 12.05 | 10.61 | 0.08 | 0.06 | | | |
| | 10 | 185.75 | 247.25 | 6.07 | 6.94 | 0.03 | 0.03 | | | |
| | 12 | 230.75 | 294.50 | 17.93 | 11.38 | 0.08 | 0.04 | | | |
| | 14 | 268.50 | 343.50 | 13.07 | 4.12 | 0.05 | 0.01 | | | |
| | A | | | | | | | 0.9987 | -25.4710 | 21.1260 |
| | B | | | | | | | 0.9977 | -12.3500 | 25.5375 |
| SR 118 | 8 | 138.00 | 131.25 | 16.24 | 5.61 | 0.12 | 0.04 | | | |
| | 10 | 158.75 | 168.25 | 8.84 | 16.68 | 0.06 | 0.10 | | | |
| | 12 | 190.75 | 186.50 | 6.94 | 6.60 | 0.04 | 0.04 | | | |
| | 14 | 226.50 | 204.00 | 12.79 | 2.44 | 0.06 | 0.06 | | | |
| | A | | | | | | | 0.9868 | 14.8750 | 14.8750 |
| | B | | | | | | | 0.9617 | 42.4250 | 11.8250 |
| SR 119 | 8 | 175.50 | 156.25 | 3.00 | 12.17 | 0.02 | 0.08 | | | |
| | 10 | 209.75 | 223.00 | 5.61 | 9.52 | 0.03 | 0.04 | | | |
| | 12 | 237.25 | 273.50 | 9.74 | 7.59 | 0.04 | 0.03 | | | |
| | 14 | 250.50 | 317.50 | 13.02 | 16.58 | 0.05 | 0.05 | | | |
| | A | | | | | | | 0.9657 | 79.3750 | 12.6250 |
| | B | | | | | | | 0.9906 | -51.2750 | 26.7125 |

Note: A = Time t_1
 B = Time t_2

TABLE 15b
 STATISTICAL EVALUATION OF DISTRICT LABORATORY DATA
 TIME A vs TIME B

| Lab Number | Cement Content | \bar{x} , Mean | | σ , Standard Dev. | | γ , Coef. of Var. | | R^2 | a | b |
|------------|----------------|------------------|--------|--------------------------|-------|--------------------------|------|--------|-----------|---------|
| | | A | B | A | B | A | B | | | |
| SR 120 | 8 | 222.00 | 177.25 | 10.00 | 6.94 | 0.05 | 0.04 | | | |
| | 10 | 293.50 | 271.00 | 33.63 | 13.11 | 0.11 | 0.05 | | | |
| | 12 | 377.00 | 335.25 | 25.50 | 44.85 | 0.07 | 0.13 | | | |
| | 14 | 470.50 | 459.75 | 8.81 | 23.62 | 0.02 | 0.05 | | | |
| | A | | | | | | | 0.9964 | -115.2000 | 41.4500 |
| | B | | | | | | | 0.9848 | -190.6500 | 45.5875 |
| SR 121 | 8 | 216.75 | 216.50 | 18.22 | 11.12 | 0.08 | 0.05 | | | |
| | 10 | 251.50 | 250.00 | 6.60 | 12.30 | 0.03 | 0.05 | | | |
| | 12 | 315.25 | 358.75 | 17.85 | 12.47 | 0.06 | 0.03 | | | |
| | 14 | 384.25 | 408.25 | 15.94 | 6.50 | 0.04 | 0.02 | | | |
| | A | | | | | | | 0.9803 | -19.5000 | 28.3125 |
| | B | | | | | | | 0.9602 | -67.8250 | 34.2000 |
| SR 122 | 8 | 232.50 | 214.00 | 23.30 | 28.49 | 0.10 | 0.13 | | | |
| | 10 | 292.75 | 293.50 | 19.44 | 9.14 | 0.07 | 0.03 | | | |
| | 12 | 351.25 | 359.25 | 30.67 | 11.20 | 0.09 | 0.03 | | | |
| | 14 | 397.25 | 378.00 | 20.85 | 15.25 | 0.05 | 0.04 | | | |
| | A | | | | | | | 0.9963 | 14.4250 | 27.6375 |
| | B | | | | | | | 0.9408 | 4.4250 | 27.8875 |

Note: A = Time t_1
 B = Time t_2

TABLE 15c
 STATISTICAL EVALUATION OF DISTRICT LABORATORY DATA
 TIME A vs TIME B

| Lab Number | Cement Content | \bar{x} , Mean | | σ , Standard Dev. | | γ , Coef. of Var. | | R^2 | a | b |
|------------|----------------|------------------|--------|--------------------------|-------|--------------------------|------|--------|----------|---------|
| | | A | B | A | B | A | B | | | |
| SR 123 | 8 | 162.00 | 165.00 | 10.61 | 5.97 | 0.07 | 0.04 | | | |
| | 10 | 188.75 | 203.00 | 36.50 | 6.16 | 0.19 | 0.03 | | | |
| | 12 | 256.50 | 236.50 | 7.59 | 6.60 | 0.03 | 0.03 | | | |
| | 14 | 315.75 | 286.00 | 31.92 | 6.73 | 0.10 | 0.02 | | | |
| | A | | | | | | | 0.9731 | -60.2000 | 26.4500 |
| | B | | | | | | | 0.9928 | 5.5000 | 19.7500 |
| SR 131 | 8 | 166.25 | 162.00 | 22.98 | 5.77 | 0.14 | 0.04 | | | |
| | 10 | 222.25 | 216.50 | 19.10 | 7.54 | 0.09 | 0.03 | | | |
| | 12 | 297.50 | 286.75 | 13.77 | 12.03 | 0.05 | 0.04 | | | |
| | 14 | 326.75 | 319.25 | 7.63 | 12.03 | 0.02 | 0.04 | | | |
| | A | | | | | | | 0.9753 | -53.0250 | 27.8375 |
| | B | | | | | | | 0.9823 | -51.9750 | 27.1000 |

Note: A = Time t_1
 B = Time t_2

TABLE 16
RESULTS OF STATISTICAL "t" TEST FOR UNPAIRED DATA

| TIME A VERSUS TIME B | | | | | | | | |
|----------------------|-------------|------------|----------------------|-------------|------------|----------------------|---------------------------|-------|
| TIME A | | | | TIME B | | | Computer Print | |
| Lab Number | \bar{x}_1 | σ_1 | $\sigma_{\bar{x}_1}$ | \bar{x}_2 | σ_2 | $\sigma_{\bar{x}_2}$ | $ \bar{x}_1 - \bar{x}_2 $ | t |
| SR 117 | 211.20 | 48.73 | 12.85 | 267.93 | 58.76 | 14.69 | 56.73 | 2.93* |
| SR 118 | 178.50 | 36.14 | 9.03 | 172.50 | 29.10 | 7.27 | 6.00 | 0.51 |
| SR 119 | 218.25 | 30.67 | 7.66 | 242.56 | 62.89 | 15.72 | 24.31 | 1.38 |
| SR 120 | 340.75 | 97.91 | 24.47 | 317.06 | 109.11 | 27.27 | 23.69 | 0.64 |
| SR 121 | 291.93 | 67.45 | 16.86 | 308.37 | 81.18 | 20.29 | 16.44 | 0.62 |
| SR 122 | 318.43 | 67.44 | 16.86 | 311.18 | 68.25 | 17.06 | 7.25 | 0.30 |
| SR 123 | 230.75 | 65.86 | 16.46 | 222.75 | 46.12 | 11.53 | 8.00 | 0.39 |
| SR 131 | 253.37 | 66.53 | 16.63 | 247.62 | 65.41 | 16.35 | 5.75 | 0.24 |

* t .05, 58 \approx 2.000 and t .05, 56 = 2.00 $\bar{x}_n = 30$ except for SR 117 $\bar{x} = 29$

as much standard deviation for one as there was for the other (see Table 17). The results did indicate achievement of higher compressive strength in each case for specimens molded with a L over D of 2:1 (from one and a half to nearly two times more than the strength of specimens molded to standard proctor size). A large number of tests would be necessary in order to draw definite conclusions as to the optimum specimen L over D which would produce more consistent compressive strength results.

Cement Recommendation System

As stated in the Laboratory Design Section, variability in a soil's cement content recommendation could occur based upon innumerable factors. Yet everyday the Department was forced into making recommendations based upon a few tests. One fact was clear: regardless of accuracy, each cement content recommendation must be similar and repeatable for each separate project. Therefore, all of the Department's previous soil-cement compressive strength data was thoroughly explored in the hopes of finding a key.

Available for study were the results of 20,000 specimens accompanied by test results of gradation, group index, plasticity index, A-group, soil type, compressive strength, geographic location and in some cases, wet-dry and freeze-thaw data.

In close cooperation with the Materials Section's Soil Unit, a system based upon compressive strength, A-group, soils types, and geographic location was developed. For example, as shown in Table 18 immediately after soils classification, the cement necessary for achieving 300 psi is known. Once this system was placed in the contracts, the contractor knew, prior to bidding, the cement recommendations for all possible soils allowable. Thus, with any preliminary soils investigation and search on his part, he could select the best and least expensive soils available. Not only will this system prevent disputes concerning cement recommendations, but it should also reduce costs.

This system has been implemented for more than a year and is being successfully used. Soil-cement compressive testing will continue in order to both to verify and improve the system.

TABLE 17
 COMPRESSIVE STRENGTH RESULTS OF SPECIMENS HAVING DIFFERENT LENGTH TO DIAMETER RATIOS

| Cement Percent | | 6 | | | 8 | | | 10 | | | 12 | | | 14 | | | |
|--------------------------------------|--------|------------|-----------|-----|------------|-----------|-----|------------|-----------|------|------------|-----------|-----|------------|-----------|-----|-----|
| L:D | | 1.146:1 | | 2:1 | 1.146:1 | | 2:1 | 1.146:1 | | 2:1 | 1.146:1 | | 2:1 | 1.146:1 | | 2:1 | |
| | | Actual PSI | Corr. PSI | | Actual PSI | Corr. PSI | | Actual PSI | Corr. PSI | | Actual PSI | Corr. PSI | | Actual PSI | Corr. PSI | | |
| COMPRESSIVE STRENGTH (7 DAY CURE) | SR5706 | | | | | | | 326 | 303 | 628 | 433 | 402 | 528 | 489 | 454 | 641 | |
| | | | | | | | | 392 | 364 | 476 | 462 | 429 | 557 | 519 | 482 | 592 | |
| | | | | | | | | 395 | 367 | 482 | 472 | 438 | 621 | 510 | 473 | 595 | |
| | | | | | | | | 387 | 359 | 529 | 476 | 442 | 543 | 497 | 461 | 628 | |
| | | | | | | | | 375 | 348 | - | 461 | 428 | 562 | 504 | 468 | 617 | |
| | SR5702 | | | | | | | | 353 | 328 | 451 | 444 | 412 | 547 | 501 | 464 | 605 |
| | | | | | | | | | 357 | 331 | 447 | 452 | 419 | 602 | 516 | 479 | 654 |
| | | | | | | | | | 368 | 342 | 479 | 439 | 407 | 570 | 498 | 462 | 634 |
| | | | | | | | | | 366 | 340 | 447 | 430 | 399 | 576 | 522 | 484 | 631 |
| | | | | | | | | | 361 | 335 | 456 | 441 | 409 | 574 | 509 | 472 | 631 |
| | SR 56 | 213 | 198 | 408 | 326 | 303 | 586 | 371 | 344 | 628 | | | | | | | |
| | | 237 | 220 | 364 | 345 | 320 | 528 | 333 | 309 | 670 | | | | | | | |
| | | 223 | 207 | 366 | 329 | 305 | 521 | 372 | 345 | 628 | | | | | | | |
| | | 224 | 208 | 385 | 310 | 288 | 547 | 385 | 357 | 680 | | | | | | | |
| | | - | - | 381 | 328 | 304 | 546 | 365 | 339 | 652 | | | | | | | |
| | SR 59 | | | | 361 | 335 | 490 | 439 | 407 | 628 | 573 | 532 | 783 | | | | |
| | | | | | 323 | 300 | 552 | 396 | 367 | 605 | 497 | 461 | 731 | | | | |
| | | | | | 344 | 319 | 571 | 407 | 378 | 618 | 555 | 515 | 819 | | | | |
| | | | | | 312 | 290 | 538 | 390 | 362 | 617 | 681 | 632 | 778 | | | | |
| | | | | | 335 | 311 | - | 408 | 379 | - | - | - | - | | | | |
| | SR 164 | 368 | 342 | 683 | 489 | 454 | 772 | 487 | 452 | 1042 | | | | | | | |
| | | 372 | 345 | 641 | 506 | 377 | 761 | 576 | 535 | 990 | | | | | | | |
| | | 336 | 312 | 657 | 460 | 427 | 809 | 571 | 530 | 987 | | | | | | | |
| | | 368 | 342 | 660 | 455 | 422 | 781 | 522 | 484 | 1006 | | | | | | | |
| 361 | | 335 | - | 478 | 444 | - | 539 | 500 | - | | | | | | | | |
| SR 165 | 386 | 358 | 657 | 571 | 530 | 809 | 739 | 686 | 1144 | | | | | | | | |
| | 396 | 367 | 647 | 567 | 526 | 846 | 714 | 663 | 1102 | | | | | | | | |
| | 387 | 359 | 659 | 584 | 542 | 832 | 732 | 679 | 995 | | | | | | | | |
| | 399 | 370 | 628 | 560 | 520 | 825 | 748 | 694 | 1110 | | | | | | | | |
| | 392 | 364 | 648 | 571 | 530 | 828 | 733 | 680 | 1088 | | | | | | | | |
| SR 181 | 322 | 299 | 447 | 350 | 325 | 560 | 485 | 450 | 650 | | | | | | | | |
| | 296 | 275 | 443 | 368 | 342 | 531 | 423 | 393 | 670 | | | | | | | | |
| | 285 | 264 | 469 | 393 | 365 | 557 | 495 | 459 | 634 | | | | | | | | |
| | 286 | 265 | 453 | 342 | 317 | 549 | 441 | 409 | 651 | | | | | | | | |
| | 297 | 276 | - | 363 | 337 | - | 461 | 428 | - | | | | | | | | |

TABLE 18
 SOIL-CEMENT REQUIREMENT CHART

PARISHES: Allen, Avoyelles, Beauregard, Grant, Natchitoches,
Rapides, Sabine, Vernon, Winn

| Soil Types | A-Group | % Cement by Volume Recommended |
|------------------------------|------------------------|--------------------------------|
| Sand | A-3 | 13% |
| Sand | A-2-4 | 10% |
| Sandy Loam | A-2-4, A-4, A-2-6, A-6 | 9% |
| Sandy Clay Loam | A-2-4, A-4, A-2-6, A-6 | 9% |
| Sandy Clay | A-2-4, A-4, A-2-6, A-6 | 11% |
| Lt. Sandy Clay | A-4, A-6 | 11% |
| Loam | A-4, A-6 | 10% |
| Clay Loam | A-4, A-6 | 10% |
| Silty Loam-50%-69% Silt | A-4, A-6 | 11% |
| Silty Loam-70%-74% Silt | A-4, A-6 | 12% |
| Silty Loam-75%-79% Silt | A-4, A-6 | 14% |
| Silty Clay Loam-50%-69% Silt | A-4, A-6 | 11% |
| Silty Clay Loam-70%-74% Silt | A-4, A-6 | 12% |
| Silty Clay Loam-75%-79% Silt | A-4, A-6 | 14% |
| Silty Clay | A-4, A-6 | 11% |
| Lt. Silty Clay | A-4, A-6 | 11% |
| <u>Silt</u> | <u>A-4, A-6</u> | <u>*</u> |

* NOTE: Must be tested prior to use. Testing time 5 weeks. (LDH TR-432)
 Corrections: The following adjustments shall be made according to the occurrence of gravel or clam shell found in the above soils. In no case shall the final cement recommended be less than 6%.

| % by weight retained on No. 4 Sieve | Cement Reduction (% by Volume) |
|-------------------------------------|--------------------------------|
| 0-14 | 0 |
| 15-24 | 1% |
| 25-39 | 2% |
| 40-60 | 3% |

SUMMARY AND CONCLUSIONS

The effort of this study consisted of an evaluation of the compressive strength of soil-cement mixtures on 15 projects, from the standpoint of design and actual achievement. The laboratory design test was examined closely along with the present field method of density control for soil-cement bases and the distribution of cement within the bases. The applicability of 300 psi used in section design of cement treated bases as related to field performance was beyond the scope of this study and, thus, not determined. However, the cement content necessary to achieve 250 and 300 psi at 7 days in the laboratory for specific soil types within a geographic area was established.

The conclusions of this study are as follows:

I Laboratory Design

Excessive inconsistency had existed when using the laboratory design method which was primarily based on compressive strength. This fact was established shortly after the commencement of this study.

This inconsistency has been reduced by: a) bringing each component in the fabrication of soil-cement specimens to the same temperature prior to molding the specimens; b) adding water to the raw soils and allowing the mixture to slake-overnight before addition of cement; c) utilizing cement whose physical and chemical properties are controlled within strict limits; d) standardizing the time required for fabrication of soil-cement specimens and e) increasing the number of specimens per percent cement from a possible of 6 to 12 in order to determine a more true mean compressive strength value.

Results of the limited investigation of effect of specimen size and molding method as related to compressive strength variations are inconclusive.

A new cement recommendation system based upon compressive strength, A-groups, soils types and geographic location was developed and has been successfully implemented.

II Field Investigation of Compressive Strengths

- (a) Based upon compressive strengths, the quality of the soil-cement bases varies greatly, both within a project and between different projects. On the average 28 day compressive strength test results of cores indicated achievement of 90 percent of the laboratory design strength base on the total project mean of 385 psi.

Under the present construction techniques of cement application, density and moisture control, a fair product is produced with 75 percent of the stations having achieved 75 percent (225 psi) of the design strength at 28 days; and the compressive strength of cores taken on 8 projects after three months or later did show achievement of well over 300 psi.

- (b) For those projects in which the laboratory design criteria was based on compressive strength, the raw soils sampled and tested in the laboratory showed substantial verification of the Materials Laboratory design. Only one project had soil types in which less than 300 psi at 7 days was obtained at the recommended cement percentages.
- (c) The present method for controlling densities of soil-cement bases in the field contains several undesirable features. When using this method, there is an implication of greater compliance to requirements than actually achieved.

There are certain Louisiana soils used in soil-cement stabilization that are more sensitive than others to delayed compaction. A loss of field compressive strength from that indicated possible by the design tests does occur. However, it does appear that acceptable base strength with time can be achieved provided good construction techniques and equipment are used and mixing and compaction time are reduced.

- (d) In-place mixing of cement with soil appears to be somewhat less than desirable. Results of 311 observations show a variation of ± 5 percent from the theoretical cement content in soil-cement bases studied. Results of the effect in cement distribution with continuous passes of a stabilizer were inconclusive; however, it did show the variation of cement content from station to station on an individual project.

RECOMMENDATIONS

1. Verification of the cement charts for the new design system developed and implemented during this study should be continued by sampling the major soil types from roadways prior to addition of cement and submitting these samples to the Materials Laboratory's Soil Unit for testing. These results should be re-evaluated on an annual basis and charts modified when necessary.

The present LDH laboratory design procedure be revised to require four specimens per each cement content for compression testing and reduce the number of cement percentages checked to three.

The effect of the length to diameter ratio on compressive strength results should be studied in order to further reduce the test variability.

2. A different method should be investigated for field compaction control. Two methods are recommended either of which would be an improvement over that presently used.
 - (a) At the present time the maximum density and optimum moisture are determined in the laboratory, however, only the optimum moisture value is reported and used in the field. The maximum density is then determined in the field at whatever moisture content is prevailing in material at that time. It is recommended that the laboratory determined maximum density be reported along with the optimum moisture content and be used in density control for the appropriate roadway segments listed on the laboratory report.
 - (b) The "control strip" concept offers a quick and flexible approach to the compaction control of bases and should be considered for use by the Department in construction of soil-cement bases.
3. Consideration should be given by the Department to requiring the use of the pugmill method of construction of soil-cement bases, especially in soil-cement shoulder construction. This method should improve the quality of soil-cement.
4. Field studies should be initiated with Tri Methylol Propane in order to determine if the detrimental effects of delayed compaction can be reduced by its use in soil-cement base construction.
5. The practice of producing suitable soils for soil-cement base construction by blending non-suitable with suitable soils on the roadway should be closely re-evaluated.
6. The present methods of distributing the cement on the roadway should be examined in depth, and a field procedure for determining cement contents in soil-cement mixtures should be developed and used on all projects. A method using a nuclear activation technique is presently being researched and shows promise. If this method is found acceptable, it should be implemented for use on all soil-cement base construction.

7. The performance of selected projects within the group studied during this research should be undertaken. The availability of basic data developed on these projects during this study would provide a good basis for determining soil-cement base performance under traffic and time.

CITED REFERENCES

- Burt, W. T. and J. Melancon. Soil-Cement Design Study, Interim Report No. 1, Research Report No. 55, Louisiana Department of Highways, May, 1971.
- . Soil-Cement Laboratory Handbook. Portland Cement Association, 1959.
- . Roland, H. L. and A. S. Kamahlioglu. A Rapid Method for Soil-Cement Design, Research Report No. 11, Louisiana Department of Highways, March, 1964.
- . Shah, S. C., et. al. AASHO Correlation Study, Research Report No. 54, Louisiana Department of Highways, September, 1971.
- . Marshall, T. J. "Some Properties of Soil Treated with Portland Cement," Symposium on Soil Stabilization (Australia). pp. 28-34.
- . Maclean, D. L. and W. A. Lewis. "British Practice in the Design and Specifications of Cement-Stabilized Bases and Subbase for Loads, "Highway Research Board No. 36, 1963, pp. 56-57.
- . Shah, S. C., J. Melancon and J. J. Hirschmann. "Control Strip Study, Interim Research Report", Research Report No. 59, Louisiana Department of Highways, January, 1972.
3. Arman, Ara. The Effect of Delayed Compaction on Stabilized Soil-Cement, Engineering Research Bulletin No. 88, Louisiana State University, Division of Engineering Research, 1965.
9. Arman, Ara. Counteraction of Detrimental Effects of Delayed Compaction. Engineering Research Bulletin No. 108, Louisiana State University, Division of Engineering Research, July, 1972.
0. Shackel, B. "A Nuclear Method for Detecting Small Variations in Density Within Soil Specimens, "Journal of the Australian Road Research Board. Australian Road Research, Volume 3, No. 9, pp. 12-34.

SELECTED REFERENCES

- Catton, Miles D. "Research of the Physical Relations of Soil-Cement Mixtures," Proceedings: Highway Research Board, Volume 20, 1940.
- Davidson, Donald T., et. al. "Moisture-Density Moisture Strength and Compaction Characteristics of Cement-Treated Soil Mixtures." Highway Research Board Bulletin No. 353.
- Folt, Earl J. "Factors Influencing Physical Properties of Soil-Cement Mixtures." Highway Research Board Bulletin No. 108.
- Girceo, L. J., et. al. "Strength-Maturity Relations of Soil-Cement Mixtures." Highway Research Board Bulletin No. 353. 1962, pp. 84-97.
- Hveem, F. N., and E. Zube. "California Mix Design for Cement-Treated Bases" Highway Research Record No. 36, 1963, pp. 11-55.
- Leadabrand, J. S., L. T. Norling and A. C. Hurless. "Soil Service as a Basis for Determining Cement Requirements for Soil-Cement Construction." Highway Research Board Bulletin No. 148.
- Robert, A. L. and M. R. Thompson. Soil Stabilization Literature Reviews. Civil Engineering Studies, University of Illinois, Urban, Highway Engineering Series 34, Illinois Highway Research Report No. 105, February, 1969.
- Sherman, George B., et. al. Overloads on Exposed Cement Treated Bases. State of California, Department of Public Works, Division of Highway, Materials and Research Department, Research Report 633107, March, 1972.
- Soil Stabilization with Portland Cement. Highway Research Board Bulletin No. 292.

APPENDIX

PROCEDURE FOR PREPARATION, MOLDING AND COMPRESSION TESTING OF SOIL-CEMENT SPECIMENS

1. Oven-dry all soil samples at 150°F and prepare to minus No. 4 sieve according to LDH TR-411.
2. Determine soil physical constants and classify according to LDH TR-407, TR-428, TR-423.
3. Determine maximum dry weight density at optimum moisture content according to LDH TR-418 (standard compactive effort in 1/30 cubic foot mold) with the following exceptions:
 - a) Slake raw soil plus water overnight at not more than five percent below the plastic limit or, if soil is non-plastic, at five percent moisture content.
 - b) After slaking period add percent cement by weight of dry soil and sufficient water to run first point, and additional water in increments of two percent for all other points needed to establish curve.
4. Design weight of each component of soil-cement mixture for compression specimens according to procedure outlined in PCA Soil Cement Handbook (1959) pages 26 and 27.
5. Mold soil-cement specimens in the laboratory and field as follows:
 - a) Laboratory molded specimens - weigh required oven-dried soil for each specimen, place in plastic bag, add 1/2 to 2/3 of required water, mix and slake overnight. After slaking period mix in designed amount of cement and add remaining water. Compact specimens with equipment and compactive effort similar to that used for moisture-density curves.
 - b) Field molded specimens - obtain soil-cement mixture from selected roadway location after compaction of cement, soil and water mixing. Mold specimens on concrete mass in three layers in proctor mold (1/30 cubic foot) at standard compactive effort.
6. Cure laboratory and designated field soil-cement specimens in 100 percent humidity room at 75°F±3° for required periods. Place specimens with top as molded down on porous stones. Protect from direct water spray for entire curing period.
7. At completion of curing period, cap specimens according to ASTM D1632, paragraph No. 9, "Capping Specimens." Soak specimens in water for four hours and test according to ASTM D1633, paragraph No. 4, "Procedure" with this exception, record actual load at failure.

Method of test for
**DETERMINING THE MINIMUM CEMENT CONTENT
FOR SOIL-CEMENT STABILIZATION**

TR-432-68
Page 1 of 1

LDH Designation: TR-432-68

1. Scope

These methods cover procedures for determining minimum cement content for soil stabilization.

2. Apparatus

As outlined in LDH TR 422 and AASHTO Designation T-136.

3. Procedure

(a) Soils for stabilization shall be tested in accordance with LDH TR-422.

(b) If the soil tested meets the requirements of (a) above, then the cement content at least equal to that in (a) above that yields a minimum unconfined compressive strength of 300 psi as run under LDH TR-422 shall be reported as the minimum required percentage.

(c) If the soil tested meets the requirements of (a) above but does not yield an unconfined compressive

strength of 300 psi or more with 14% or less cement by volume, then the soil shall be tested in accordance with AASHTO Designation T-136. The cement content at which the soil tested passes both (a) above and AASHTO Designation T-136 shall then be reported as that required for stabilization except that 14% cement by volume shall be the minimum recommended if less than 300 psi is obtained under (b) above.

4. Report

The minimum cement content meeting the above listed criteria shall be reported as the percentage by volume required for cement stabilization provided that

(a) No percentage shall be recommended at less than 8.0% by volume.

(b) Soils will not be tested at cement contents higher than 14.0% by volume unless specifically required.

NOTE: For those soils requiring hydrated lime conditioning prior to cement stabilization, the soils shall be conditioned in accordance with LDH TR-418 and then tested as above.

Method of Rapid Design For
THE CEMENT CONTENT OF SOIL-CEMENT MIXTURES
 by
THE LOUISIANA SLOPE VALUE METHOD
 LDH DESIGNATION: TR 422-66

LDH TR 422-66
 Page 1 of 3

Scope

1. This method is intended for determining the minimum cement requirement for design use in the construction of soil-cement base and subbase courses.

Test Methods

2. (a) Soil samples shall be prepared in accordance with AASHTO Designation: T 87-49 (LDH Designation: 411-58) Standard Method of Dry Preparation of Disturbed Soil Samples for Test.

(b) Soils shall be classified in accordance with AASHTO Designation: M 145-49 - The Classification of Soils and Soil Aggregate Mixtures for Highway Construction Purposes.

(c) The moisture-density relations of the soil-cement mixture shall be determined by adhering to AASHTO Designation: T 134-57 - Standard Methods of Test for Moisture-Density Relations of Soil-Cement Mixtures.

(d) Specimens for unconfined compressive strength determinations shall be molded in accordance with Paragraph 4, ASTM Designation: D 559-57 - Wetting and Drying Tests of Compacted Soil-Cement Mixtures.

(e) The compressive strength specimen shall be tested in accordance with ASTM Designation: D 1633-59T with the following exceptions:

(1) Test specimens shall have a diameter of 4.0 inches and a height of 4.6 inches.

(2) Specimens shall be moist room cured at approximately 100% relative humidity for a period of seven days.

(3) Immediately upon removal from the moist room, the specimens shall be measured for height and diameter, capped with a commercial capping compound (Trade Name: Vitrobond or gypsum plaster), and

immersed in clean water for a period of four hours prior to testing.

Procedure

After the soil is classified, a range of cement contents is selected according to the following: A-2-4, A-3 and A-4 should be molded at cement contents ranging from 5% to 9% by weight, and the range for A-6 soils should be from 6% to 10% by weight.

A minimum of two (preferably three) cylinders are molded at each of the three cement contents selected, tagged and cured in the moist room for the required 7 days, after which the samples are measured, capped and immersed in water for 4 hours prior to testing for unconfined compressive strength. Upon completion of the compressive strength, the appropriate "slope values" are determined by the following formula:

$$\text{Slope Value} = \frac{B-A}{Y-X} \times \frac{1}{100} \text{ or } \frac{C-B}{Z-Y} \times \frac{1}{100}$$

Where:

A = Unconfined compressive strength at the lowest cement content.

B = Unconfined compressive strength at the median cement content.

C = Unconfined compressive strength at the highest cement content.

X = Lowest cement content by weight.

Y = Median cement content by weight.

Z = Highest cement content by weight.

"Maximum Slope Value" represents the highest value obtained from the above expression and is used for A-2-4, A-3, and all A-4 soils with plasticity indices of ten or less. "Minimum Slope Value" would be the lowest value derived from the above formula and is used for the A-6 and A-7-6 groups of soils. For example:

| Point | Cement Content % by Weight | Failure Stress PSI |
|-------|-------------------------------|-----------------------|
| A | 5.08 | 342 |
| B | 6.89 | 455 |
| C | 8.77 | 603 |

$$\text{Maximum Slope Value} = \frac{603 - 455}{8.77 - 6.89} \times \frac{1}{100} = 0.79$$

$$\text{Minimum Slope Value} = \frac{455 - 342}{6.89 - 5.08} \times \frac{1}{100} = 0.62$$

The appropriate slope value is then located on the cement content requirement proper chart or on the following table for the minimum

MINIMUM CEMENT REQUIREMENT

USING THE LOUISIANA SLOPE VALUE METHOD

| Soil Classification | Slope Value Type | Slope Value | Min. Cement Requirement by Weight, % |
|-------------------------------------|------------------|-------------|--------------------------------------|
| A-2-4, A-3 | Maximum | 0.46 - 0.60 | 6 |
| | | 0.61 - 0.85 | 7 |
| Non-plastic A-4 (P.I. 0.0 - 3.0) | Maximum | 0.24 - 0.36 | 5 |
| | | 0.37 - 0.56 | 6 |
| | | 0.57 - 0.75 | 7 |
| | | 0.76 - 0.90 | 8 |
| | | 0.91 - 0.94 | 9 |
| Plastic A-4 (P.I. 3.0 - 10.0) | Maximum | 0.18 - 0.20 | 5 |
| | | 0.21 - 0.30 | 6 |
| | | 0.31 - 0.67 | 7 |
| | | 0.68 - 1.25 | 8 |
| A-6 and A-7-6 | Minimum | 0.17 - 0.27 | 8 |
| | | 0.28 - 0.34 | 7 |
| | | 0.35 - 0.36 | 6 |

Note: Slope values which vary greatly from the limiting values should be verified by the complete Wetting-Drying Test (AASHTO Designation: T 135-57).

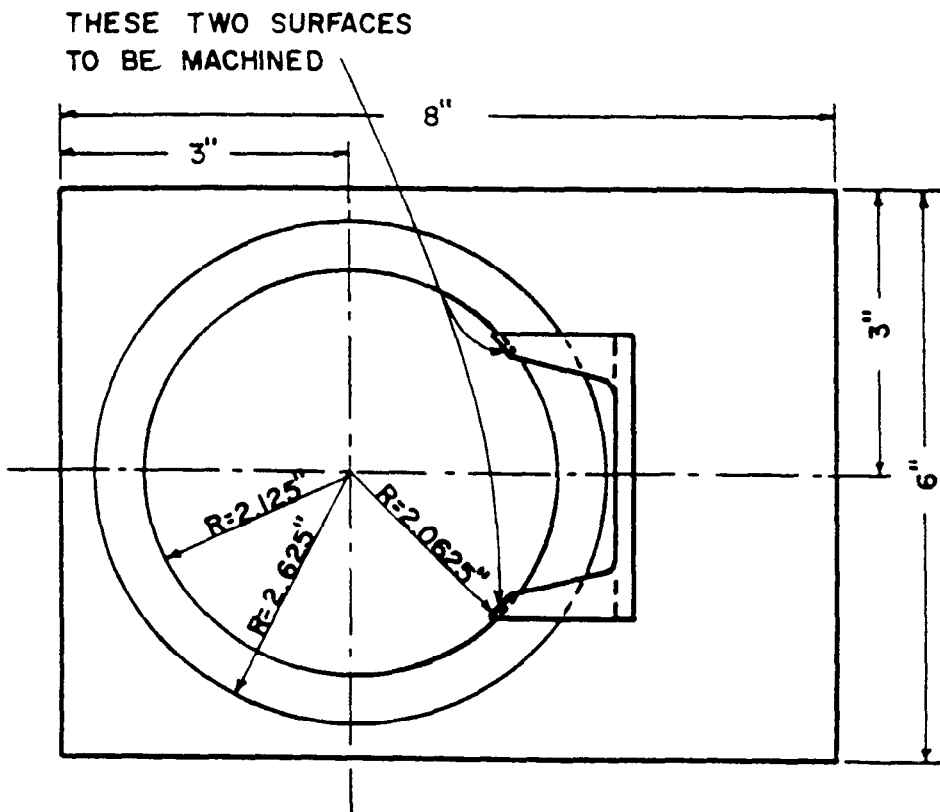
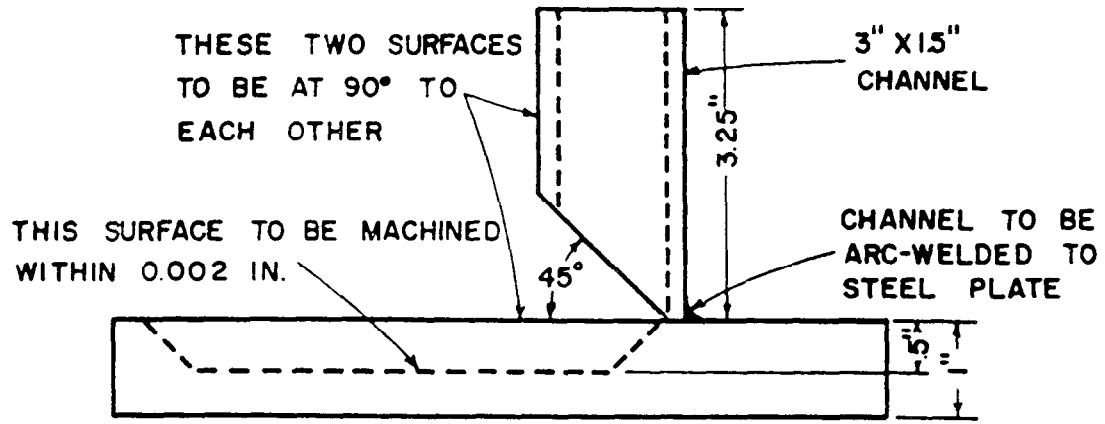

Cylinder Capping Mold

CEMENT CONTENT OF SOIL-CEMENT MIXTURES

SCOPE

The laboratory determination of cement content in soil-cement mixtures.

APPARATUS

1. Analytical balance capable of weighing to .0001 of a gram.
2. No. 40 Whatman filter paper.
3. Furnace capable of 1200°F.
4. No. 40 sieve.
5. Glass funnels and beakers.
6. Jaw crucible.
7. Hot plate.
8. Dessicator.

REAGENTS

1. Ammonium hydroxide (1:1) ratio.
2. Hydrochloric acid (1:1) ratio.
3. Ammonium oxalate solution (50 gram/lites).
4. Methyl orange indicator (1 gram/lites).

SAMPLE

1. Raw soil.
2. Sample of Portland Cement used.
3. Soil-cement mixture to be tested.
4. Sample size - 200 grams and passing No. 40 sieve.

PROCEDURE

1. Dry one gram of material (.50 gram for Portland cement) in an oven overnight at 230°F.
2. Record dry weight of sample.
3. Place sample in beaker, add 1:1 HCl, pulverize with glass rod and allow one minute for digestion.
4. Add distilled water and evaporate until dry.
5. Add 25 ml of 1:1 HCl and heat for 10 minutes at 80°C.
6. Filter the sample and wash with hot HCl and then 3 times with hot H₂O.
7. Discard the precipitate.
8. Heat filtrate on hot plate to 80°C for five minutes.
9. Add three drop of methyl orange to filtrate.
10. Add ammonium hydroxide slowly until yellow color appears, then boil for one minute. Do not allow sample to sit for more than five minutes before filtered. Filter the sample through two filter papers.

11. Wash filter paper with hot distilled water three times. Discard precipitate.
12. Place filtrate on hot plate until temperature reaches 80°C, then add HCl until solution turns red.
13. Add 30 cc of ammonium oxalate and allow precipitate to form for five minutes. Add HCl, a drop at a time, until all precipitate is dissolved.
14. Let solution digest for five minutes.
15. Add NH₃OH until precipitate forms, bring to boil, then remove from hot plate. Allow the sample to sit for 30 minutes undisturbed.
16. Filter the sample through two No. 40 filter papers, wash three times, then discard filtrate.
17. Place the filter paper and the precipitate in a crucible on a hot plate at 500°F for 30 minutes.
18. Place the crucible in a furnace at 1200°F for four hours.
19. Remove crucible from furnace and place in dessicator to cool.
20. Weigh residue (CaO) to .0001 of a gram.

CALCULATIONS

$$1. \quad \% \text{ CaO in Portland Cement} = \frac{\text{wt. CaO}}{\text{wt. of dry sample}} \times 100$$

$$2. \quad \text{Weight of CaO in Raw Soil} = \frac{\text{wt. of CaO}}{\text{wt. of dry sample} - \text{wt. CaO}}$$

$$3. \quad \text{Weight of CaO in Soil-Cement Mixtures} = \frac{\text{wt. of CaO}}{\text{wt. of dry sample} - \text{wt. CaO}}$$

$$4. \quad \% \text{ Portland Cement in Soil-Cement Mixtures} = \frac{\text{wt. of CaO (S/C)} - \text{wt. of CaO (RS)}}{\text{CaO of Portland Cement}} \times 100$$

CALCIUM IN SOIL CEMENT
BY
ATOMIC ABSORPTION SPECTROPHOTOMETRY

Spectrophotometer:

A Perkin-Elmer 403 Atomic Absorption Spectrophotometer using a reducing air-acetylene flame with a four inch single slotted burner head.

Reagents:

- (a) Hydrochloric Acid (1-1)
- (b) Lanthanum solution five percent (w/v)
Wet 58.65 gm La_2O_3 with deionized water and add 250 ml concentrated HCl very slowly until the material is dissolved. Dilute to 1 liter with deionized water.

Standards:

National Bureau of Standards Cement 1015. Transfer 0.25 gm standard cement in a beaker and add 25 ml (1-1) HCl and after completely dissolving filter into a 200 ml volumetric flask. Wash the filter paper several times with hot one percent HCl and dilute after cooling to 200 mls. Transfer a one ml aliquot from the 200 mls of solution to a 100 ml volumetric flask and add 20 mls Lanthanum solution and dilute to 100 mls. Final dilution is 1:20000.

$$\text{ppm} = \frac{10^6 \times \text{sample weight} \times \% \text{ Calcium in standard}}{\text{dilution factor} \times 100}$$

Procedure:

The core is fractured and dried at 230°F for a minimum of 48 hours and then ground using a Bico pulverizer with ceramic plates to 100 percent passing No. 100 mesh. The sample is then blended and mixed and a 20-30 gm fraction is ground again for 30 seconds using an Angstrom grinder with ring and puck assembly reducing the particle size to less than 200 mesh. The 20-30 gm fraction is then kept in an oven at 212-225°F for six hours or longer. A sample from 0.2480-0.2600 gms of known weight is then placed in a 250 ml beaker and 25 ml HCl (1-1) is added and heated on a hot plate until solution is complete.

The solution is then filtered directly into a 200 ml volumetric flask using No. 40 Whatman ashless filter paper. Wash the separated SiO_2 several times with hot one percent HCl.

Allow the solution to cool and dilute to 200 mls and mix. Take a 10 ml aliquot from the 200 ml volumetric flask and transfer to a 100 ml volumetric flask. To this add 20 mls of the Lanthanum solution and dilute to 100 mls and mix. This gives a final concentration of one percent (w/v) Lanthanum.

Standardize the Spectrophotometer in the concentration mode with the NBS cement standard. Aspirate the solution from the 100 ml volumetric flask and read out the concentration in ppm from the digital readout.

If the concentration of the sample is higher than the range of linearity for Calcium dilute the sample to bring it in range and near the concentration of the standard.

CALCULATIONS

$$\% \text{ Ca in Standard} = \frac{\text{molecular wt. Ca.} \times \% \text{ CaO in NBS Standard}}{\text{molecular wt. CaO}}$$

$$\% \text{ Ca O} = \frac{\text{dilution factor} \times \text{ppm} \times \text{mol. wt. CaO}}{10000 \times \text{sample wt.} \times \text{mol. wt. Ca}}$$

$$\% \text{ CaO (due to cement)} = \% \text{ Ca) of sample} - \% \text{ CaO of raw soil}$$

$$\% \text{ Cement} = \frac{\% \text{ CaO due to cement}}{\% \text{ CaO of cement used}}$$

$$\% \text{ Cement (dry wt.)} = \frac{\% \text{ cement}}{1 - \frac{\% \text{ cement}}{100}}$$

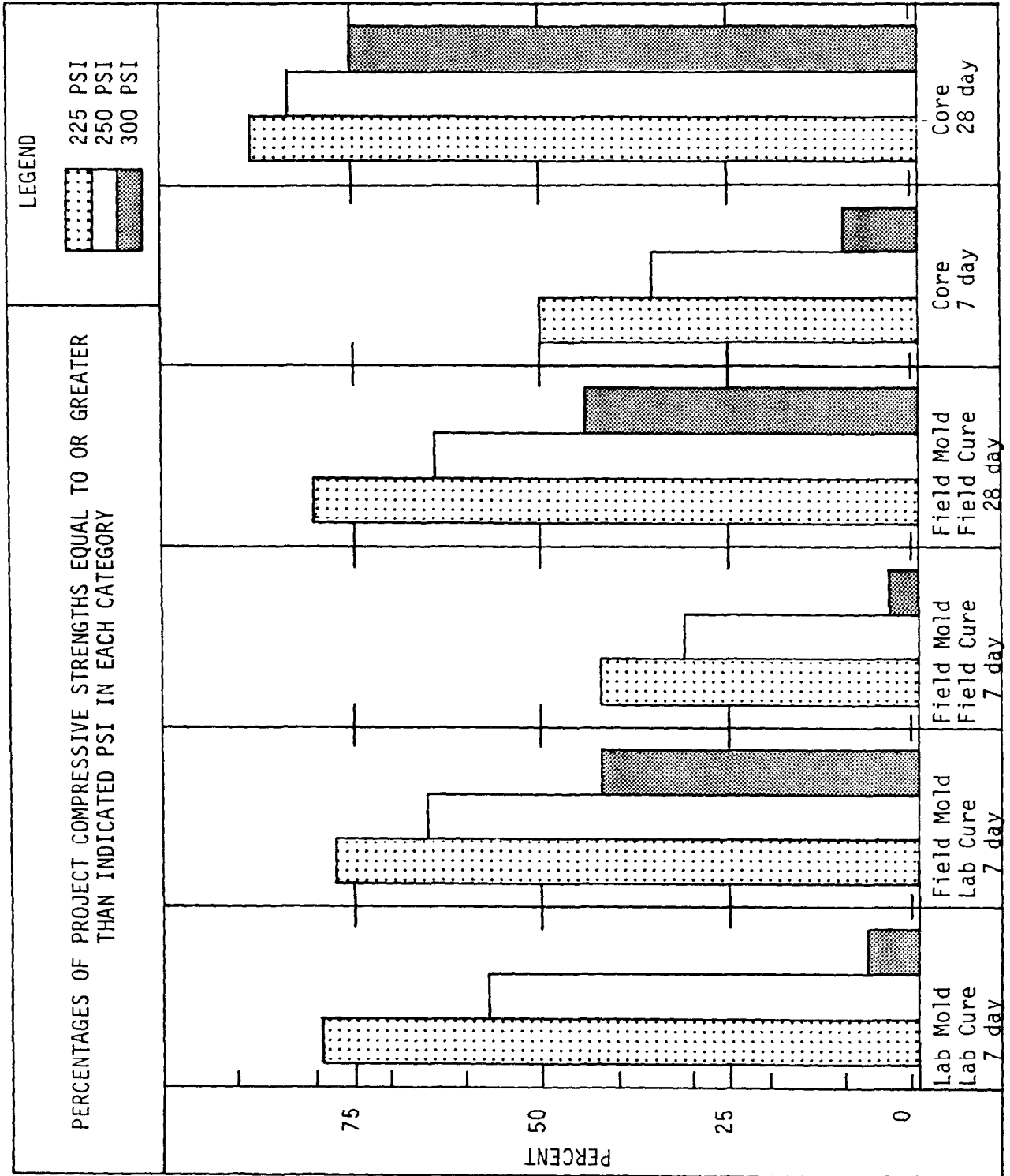

FIGURE 12

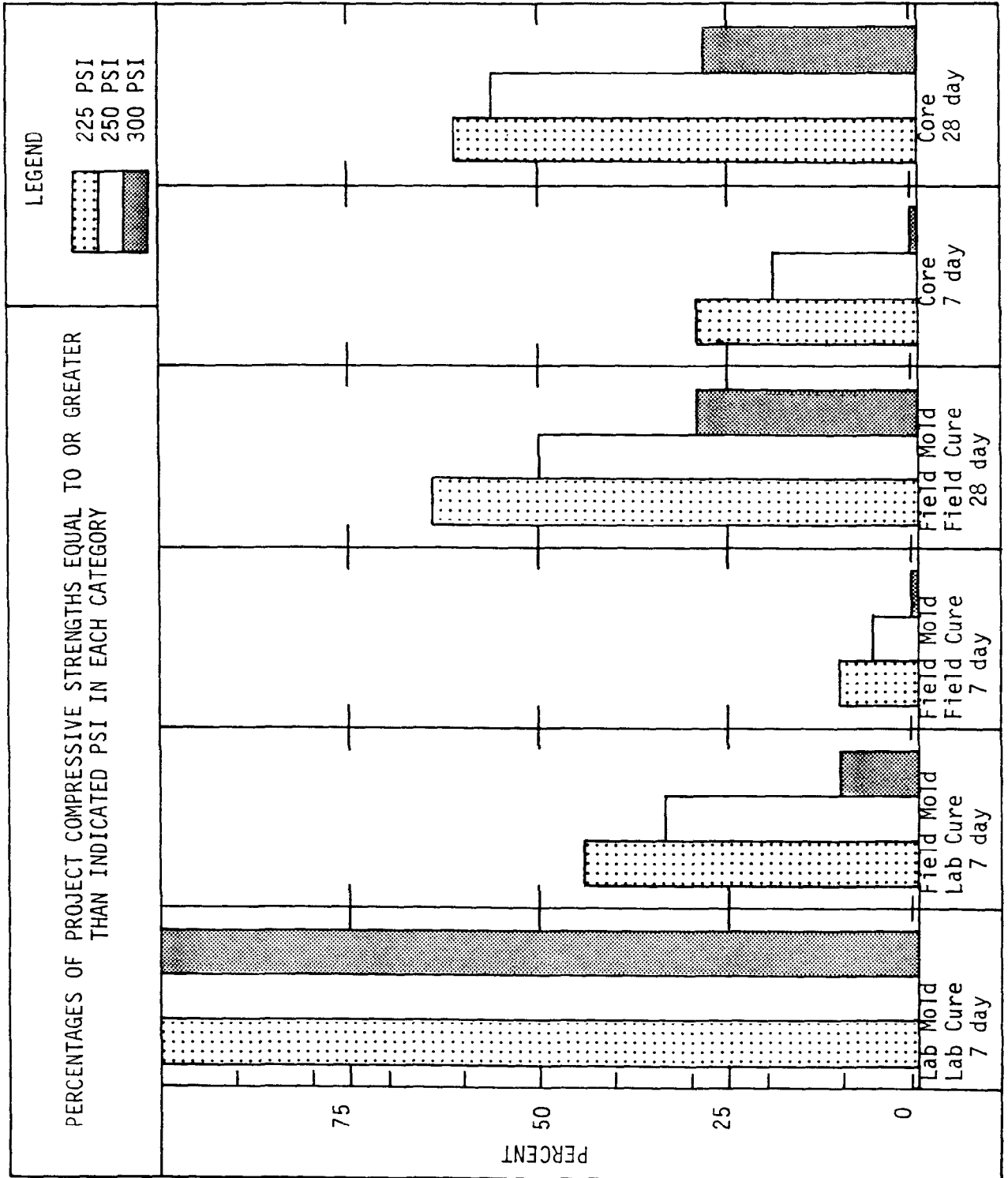

FIGURE 13

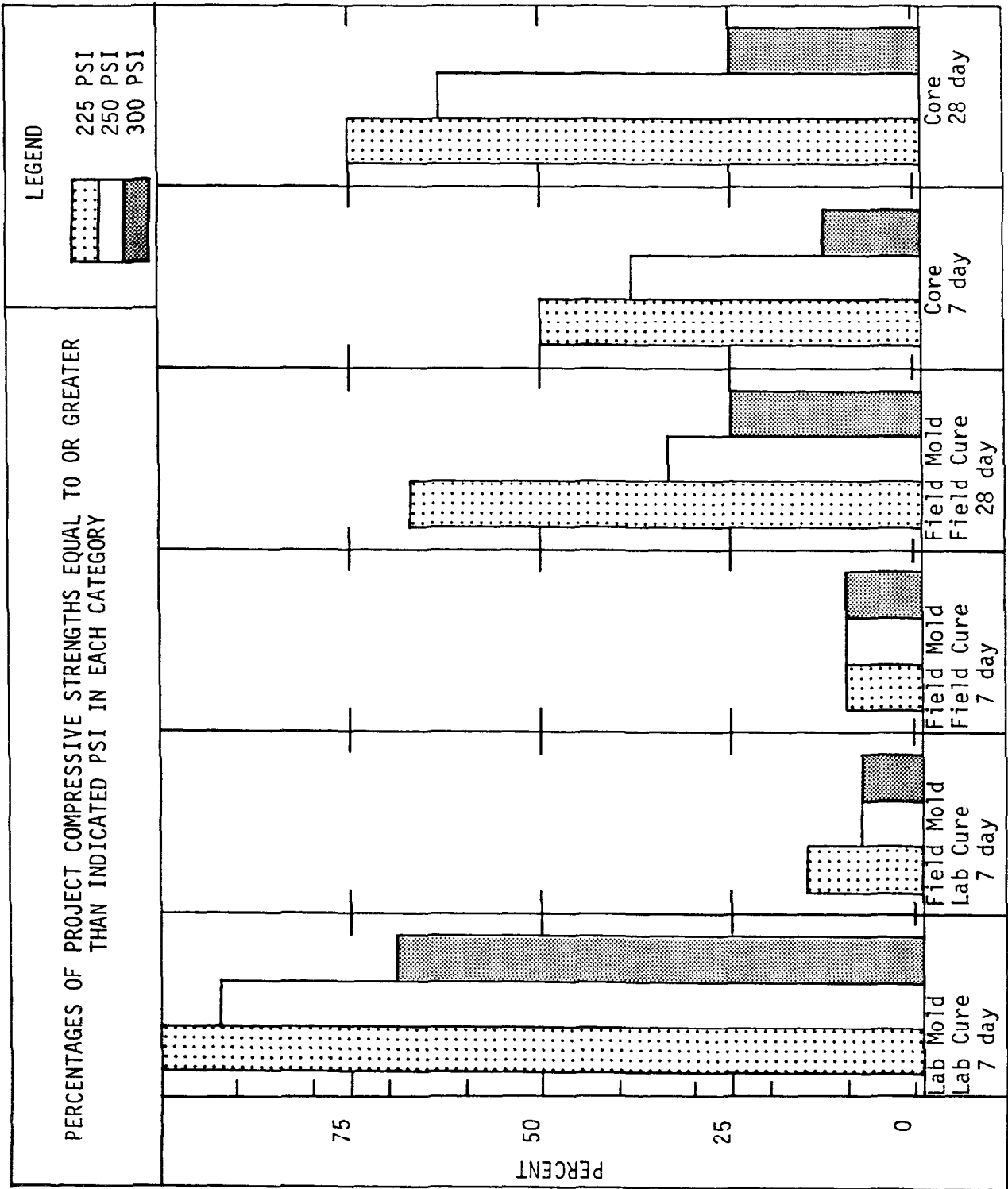

FIGURE 14
70

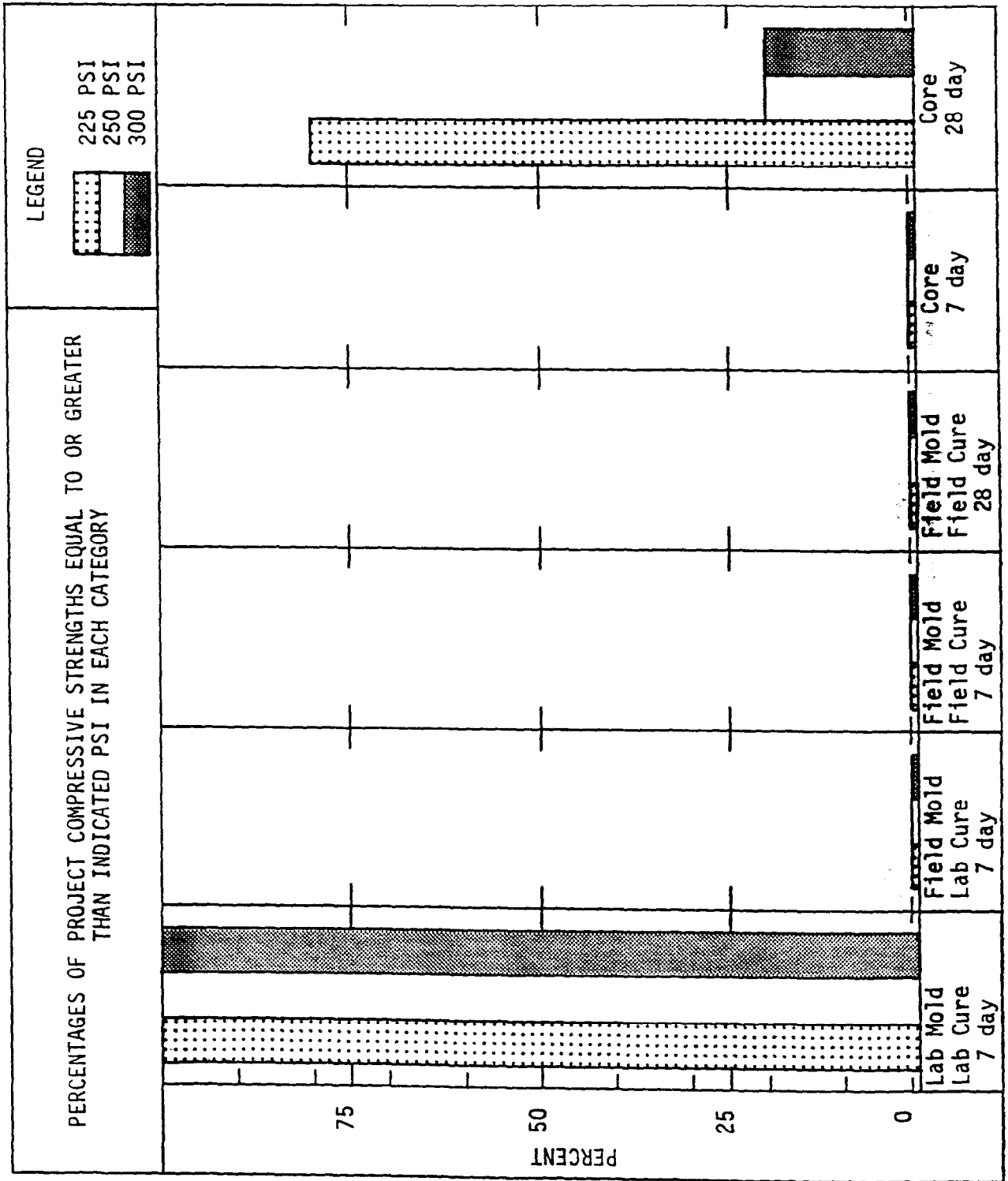

FIGURE 15

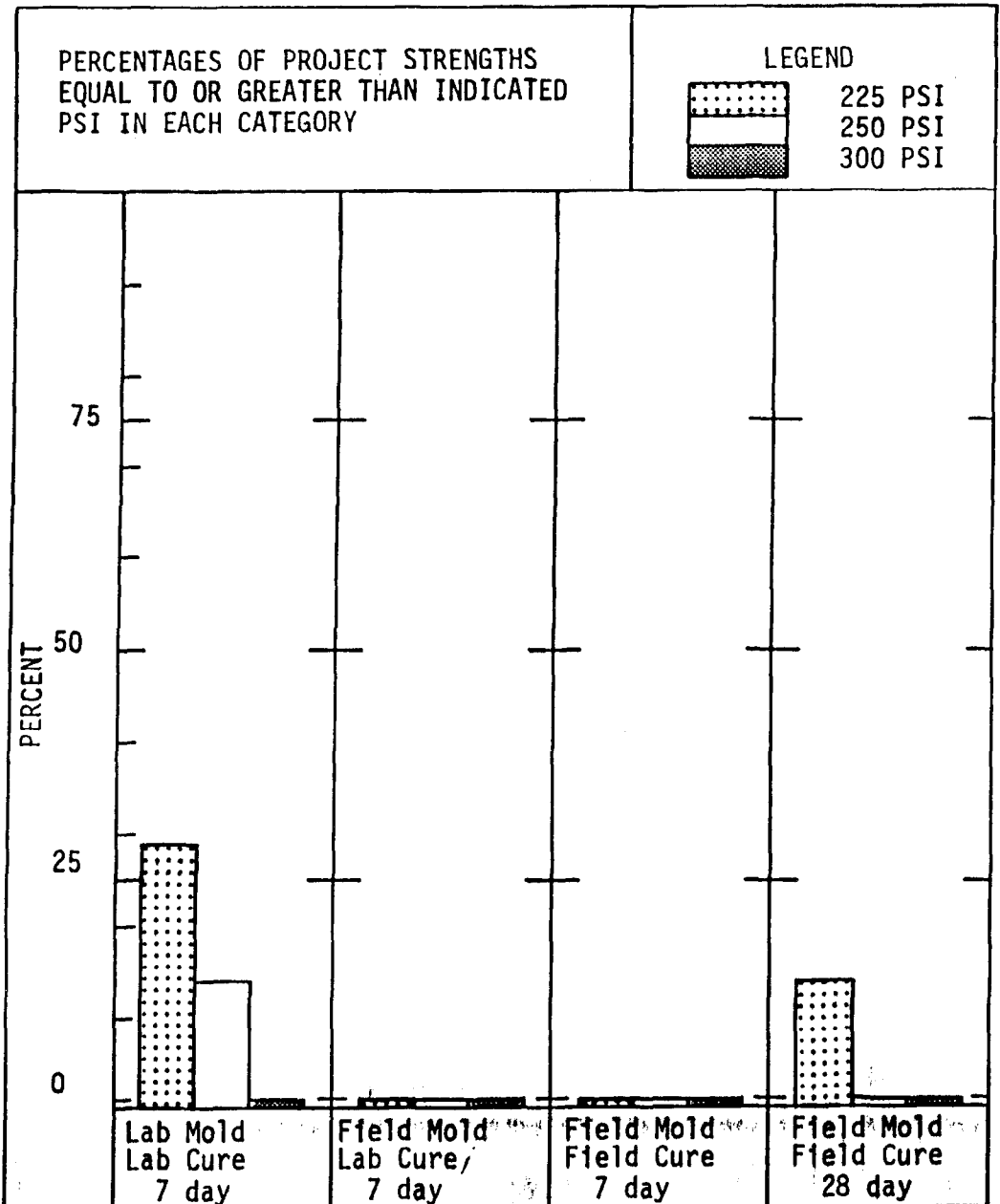

FIGURE 16

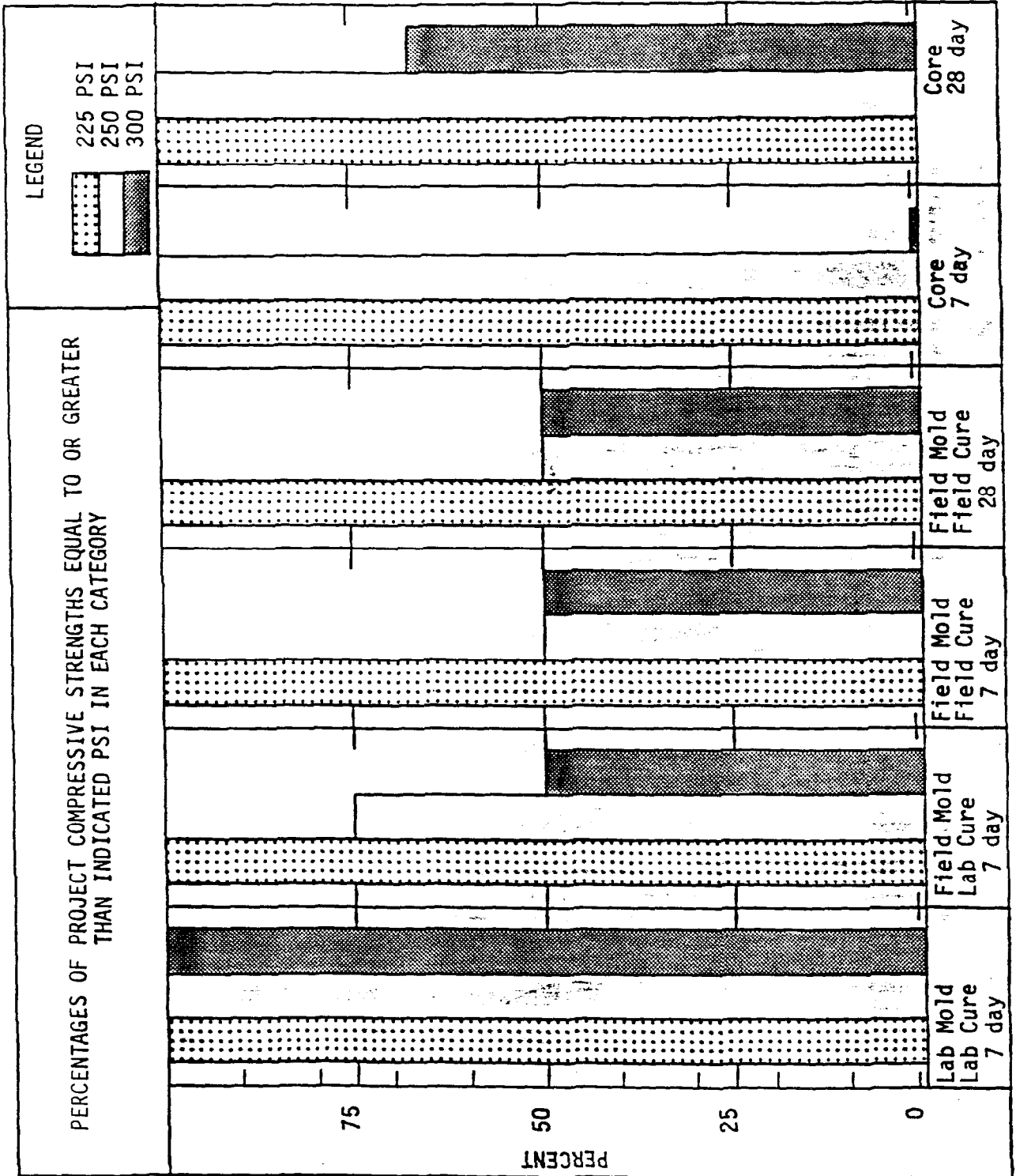

FIGURE 17

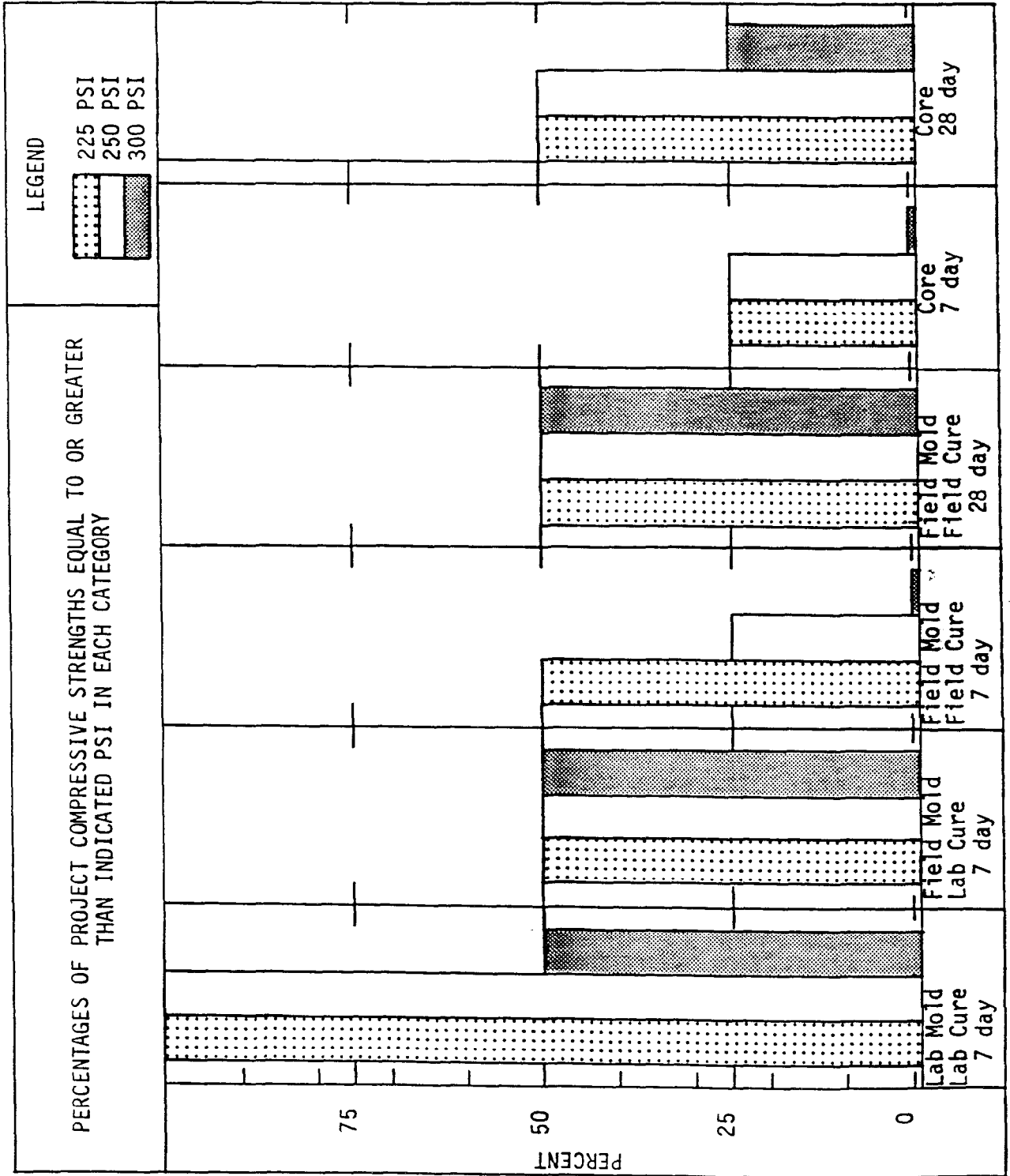

FIGURE 18

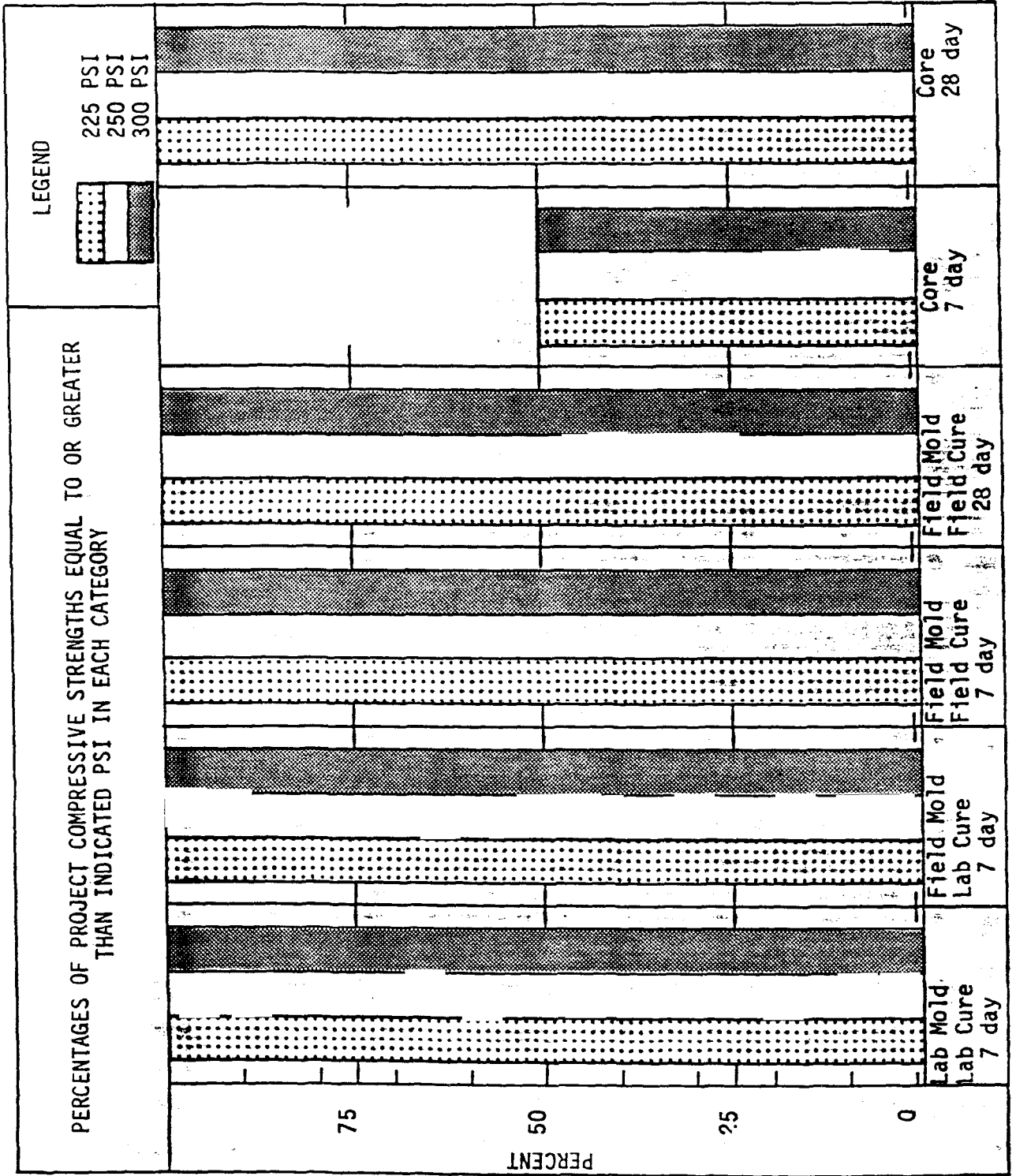

FIGURE 19

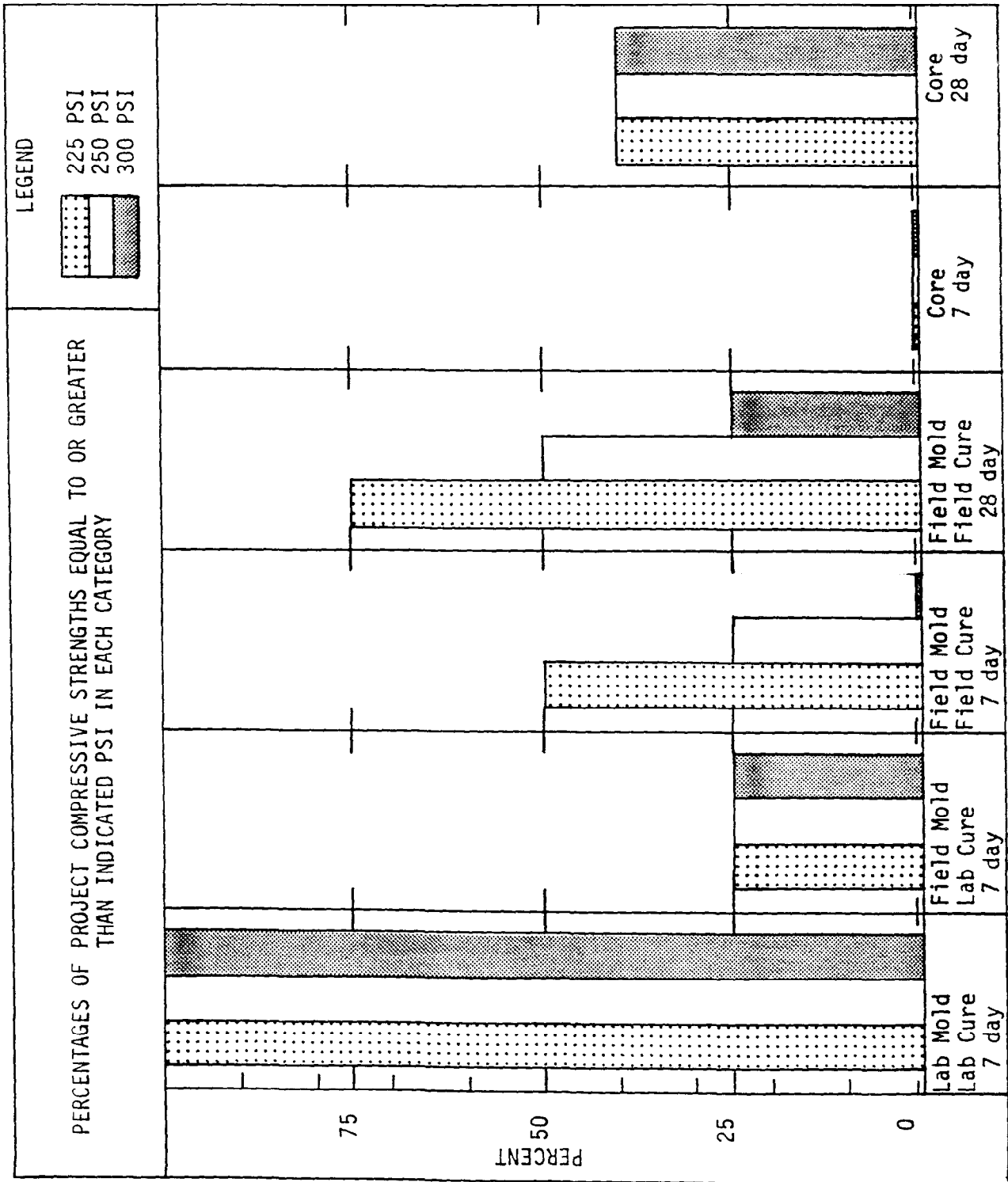

FIGURE 20

PROJECT 10

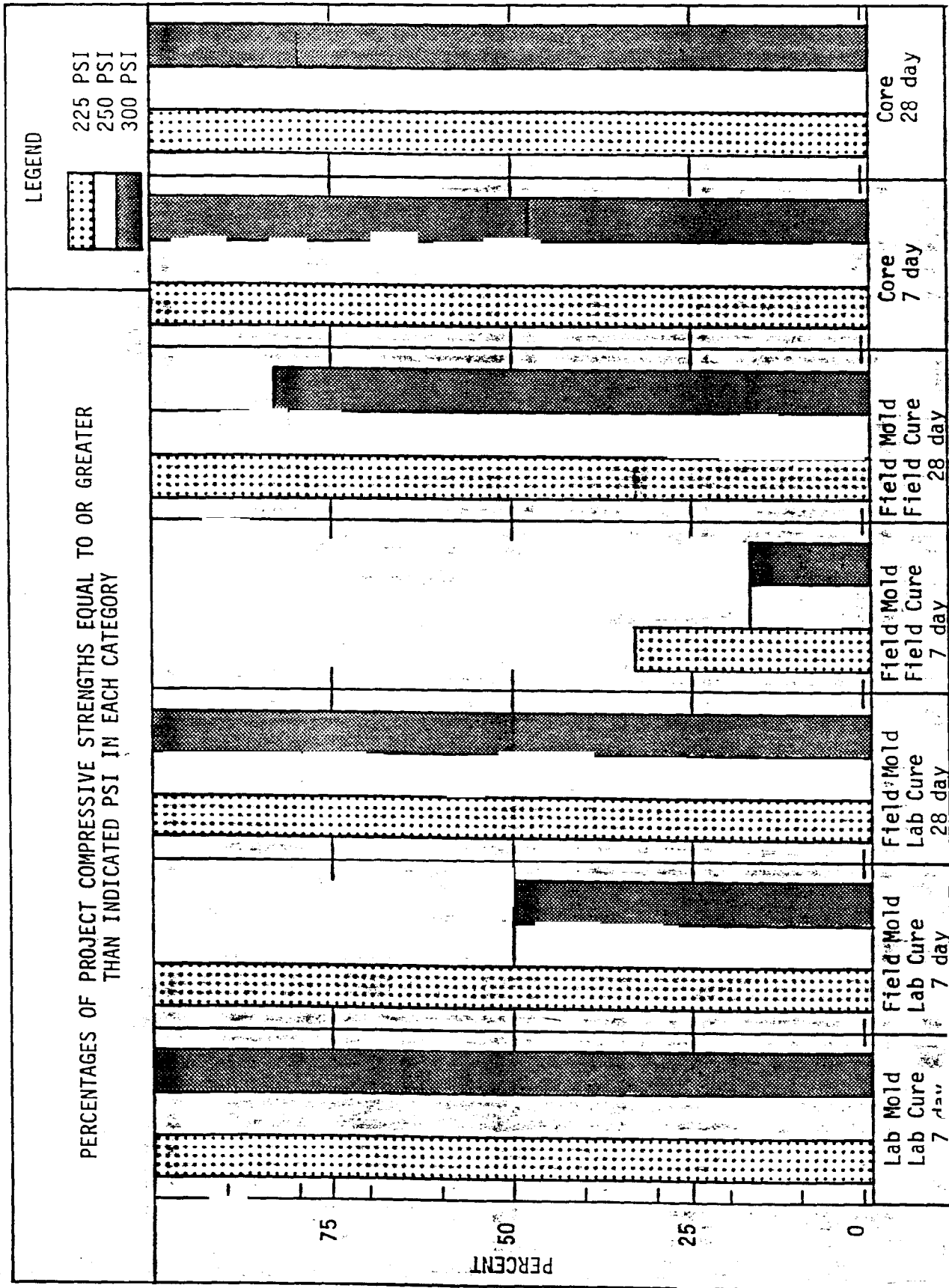

FIGURE 21

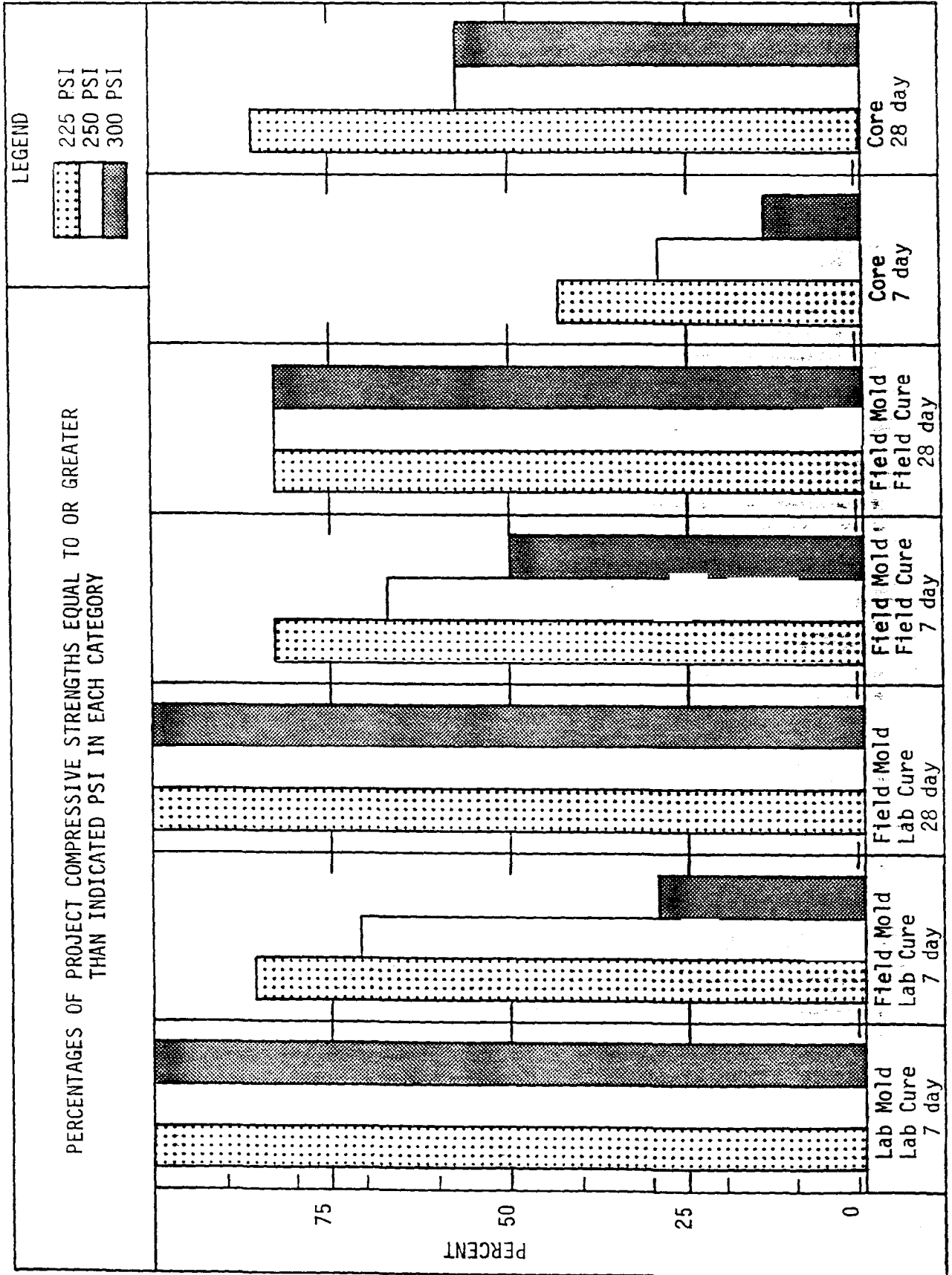

FIGURE 22
78

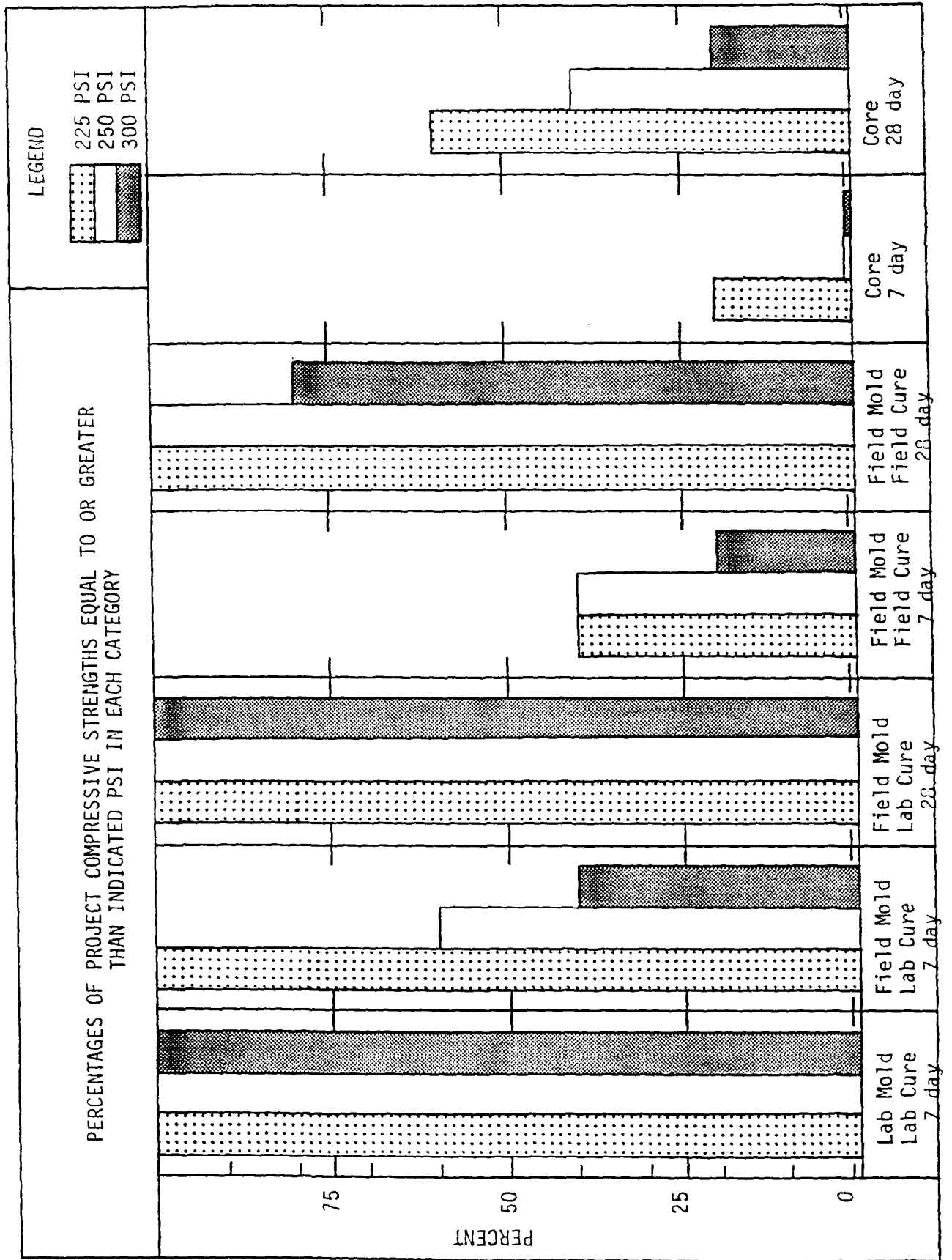

FIGURE 23

PERCENTAGES OF PROJECT COMPRESSIVE STRENGTHS EQUAL TO OR GREATER THAN INDICATED PSI IN EACH CATEGORY

LEGEND

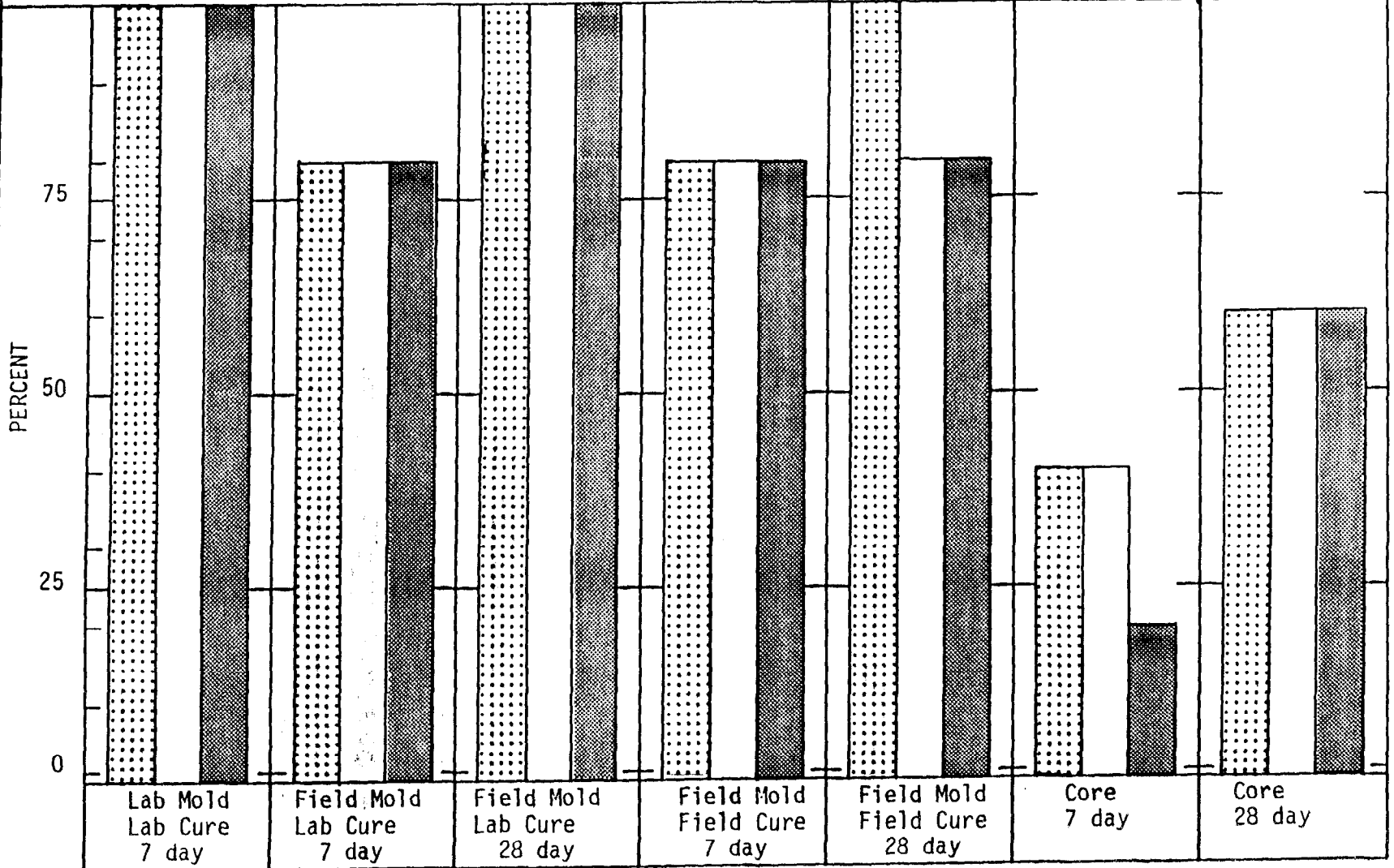
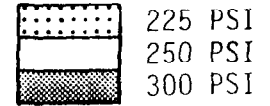

FIGURE 24
80

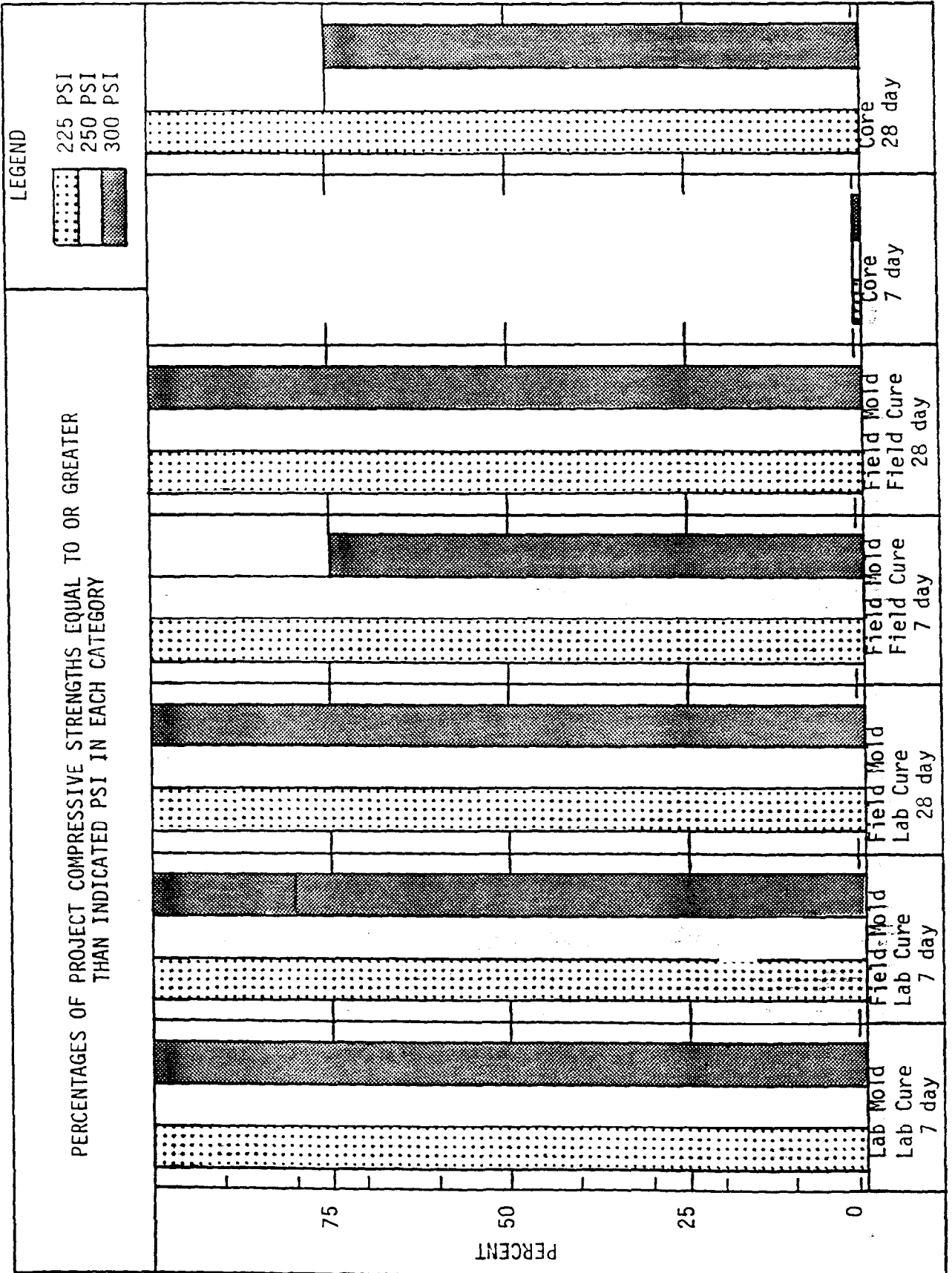

FIGURE 25

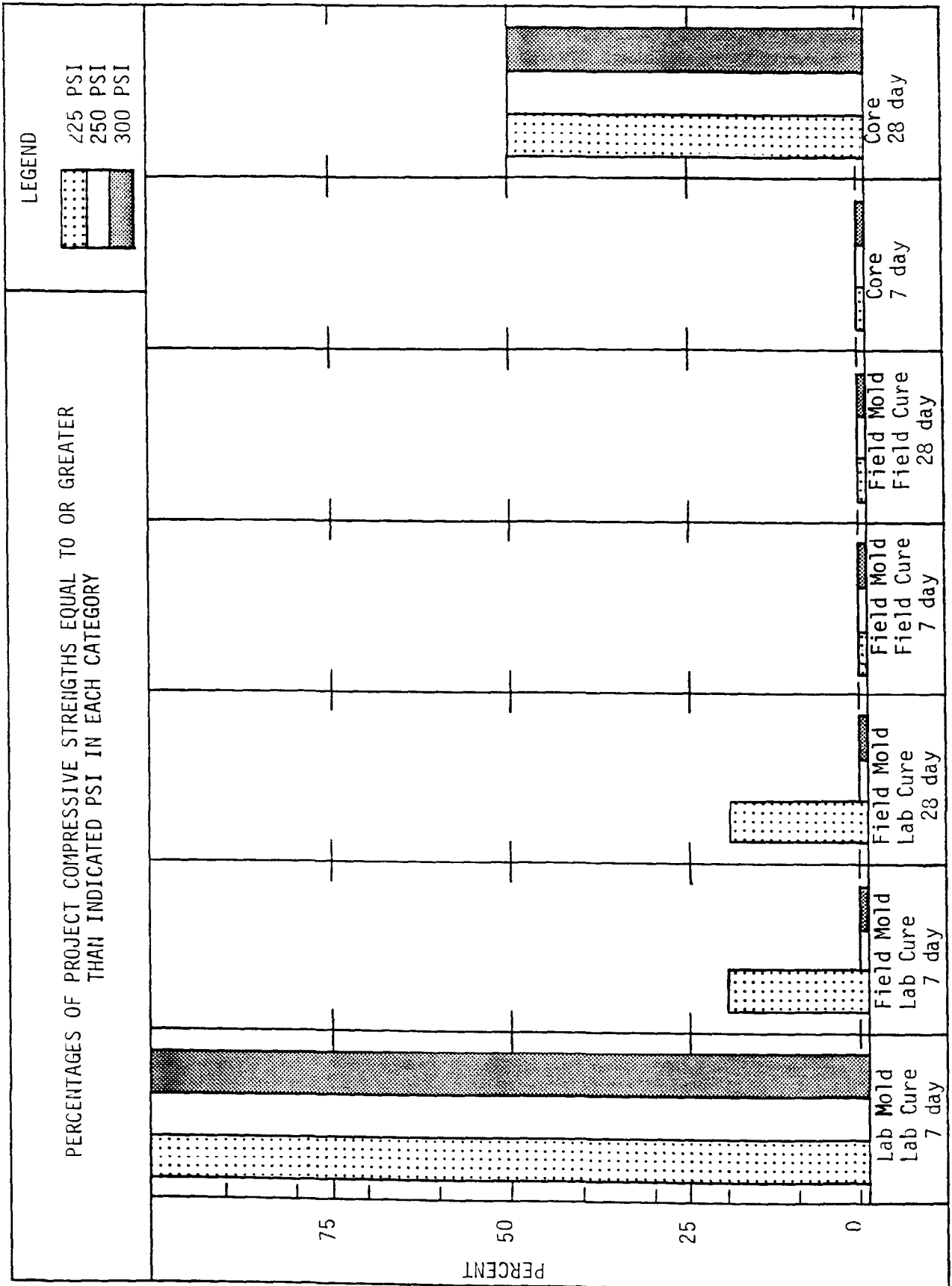

FIGURE 26

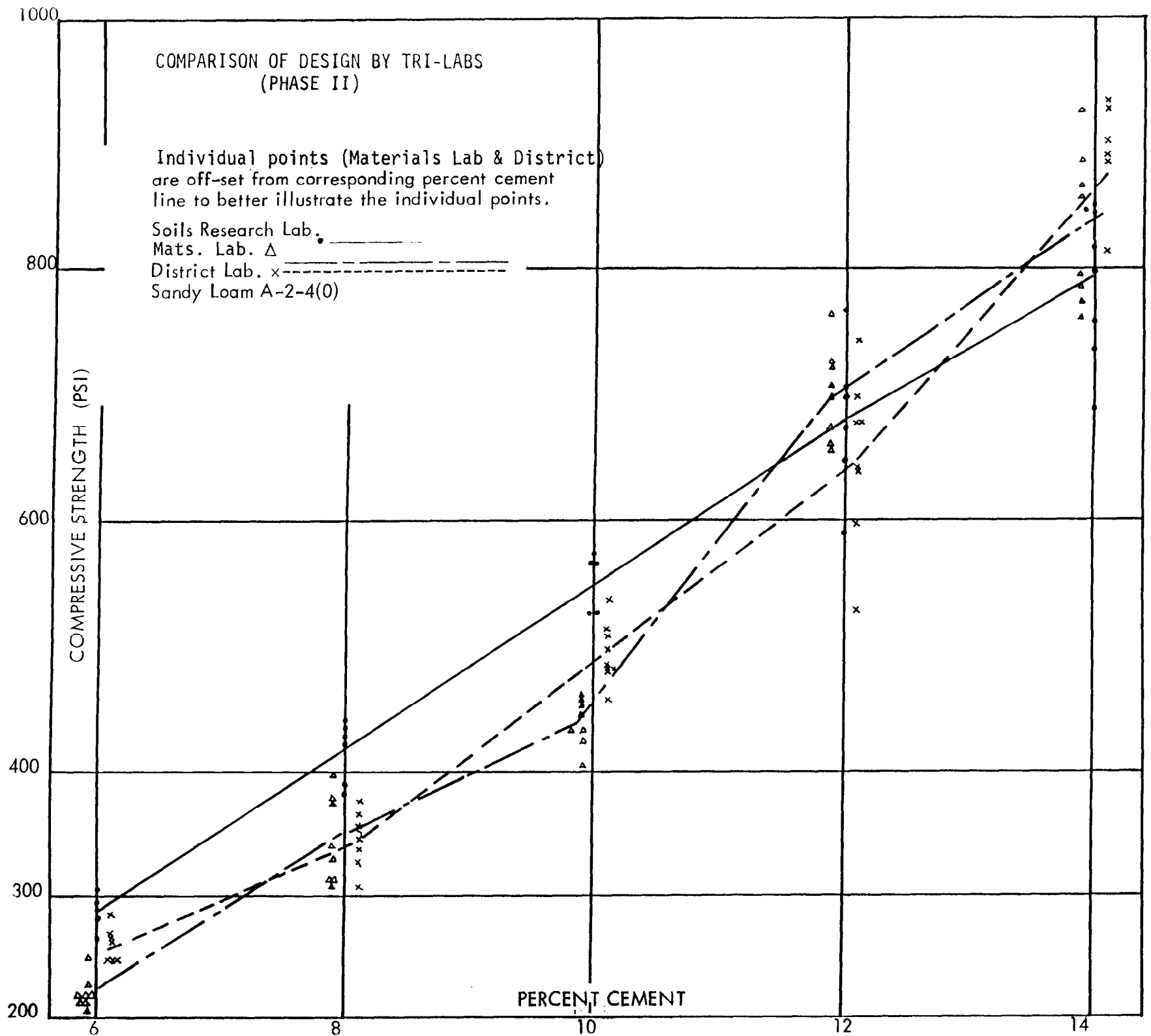
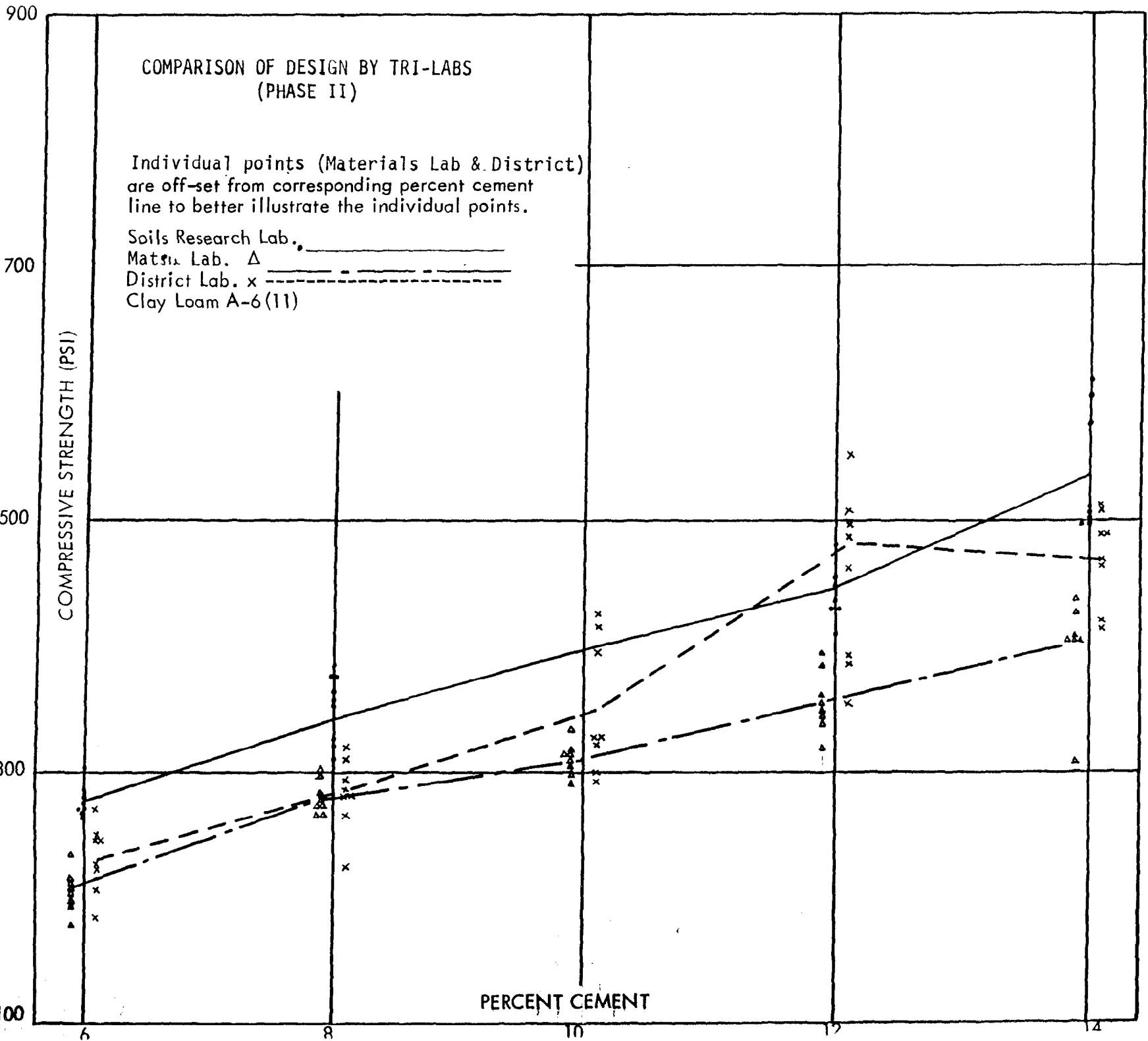
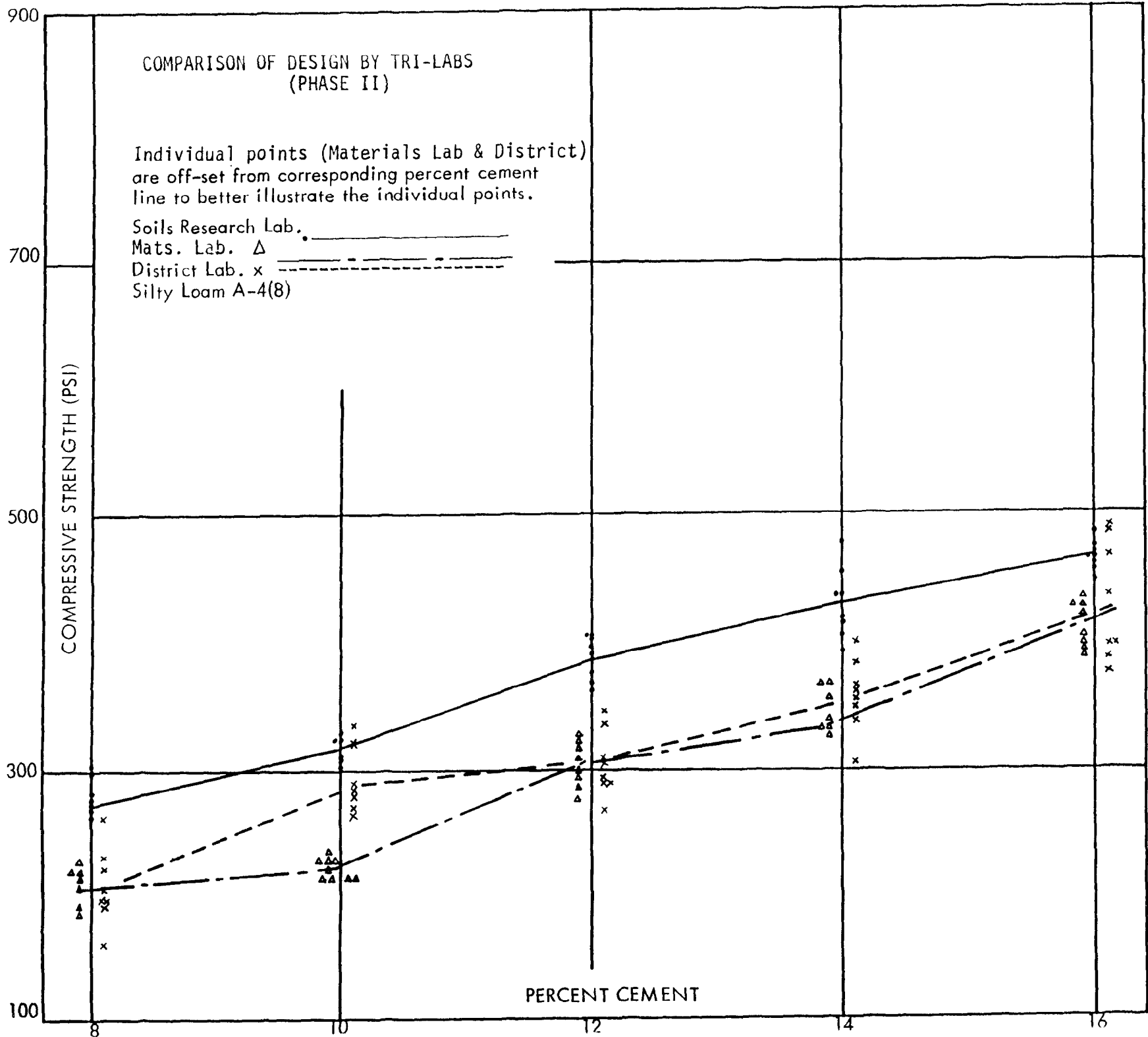

FIGURE 27a



84
FIGURE 27b

85
FIGURE 27c



COMPARISON OF DESIGN BY TRI-LABS
(PHASE III)

Individual points (Materials Lab & District Lab) are off-set from corresponding percent cement line to better illustrate the individual points.

Soils Research Lab ○ ———
Mats. Lab. △ ———
District Lab x - - - - -
Sandy Loam A-4(2)

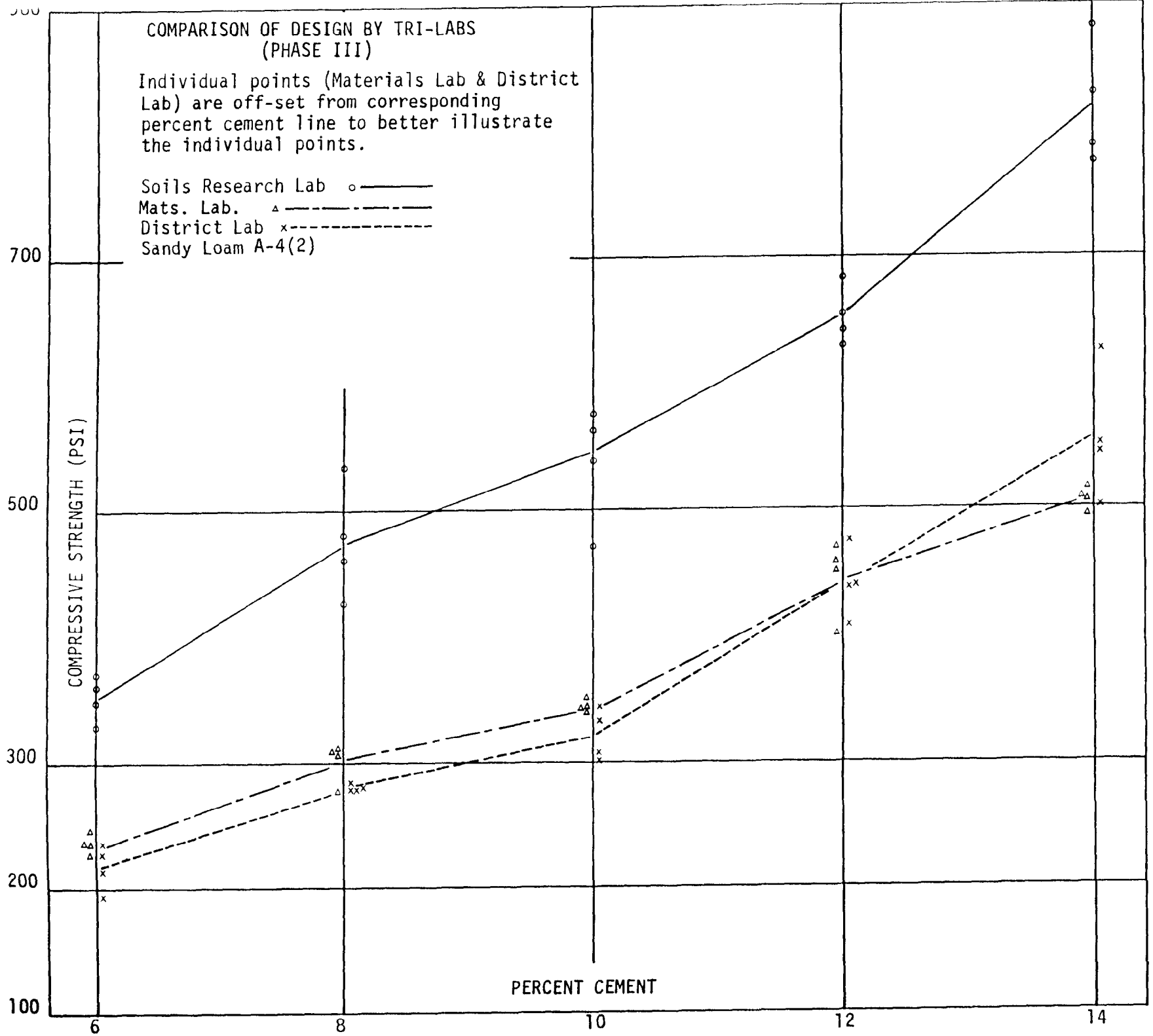
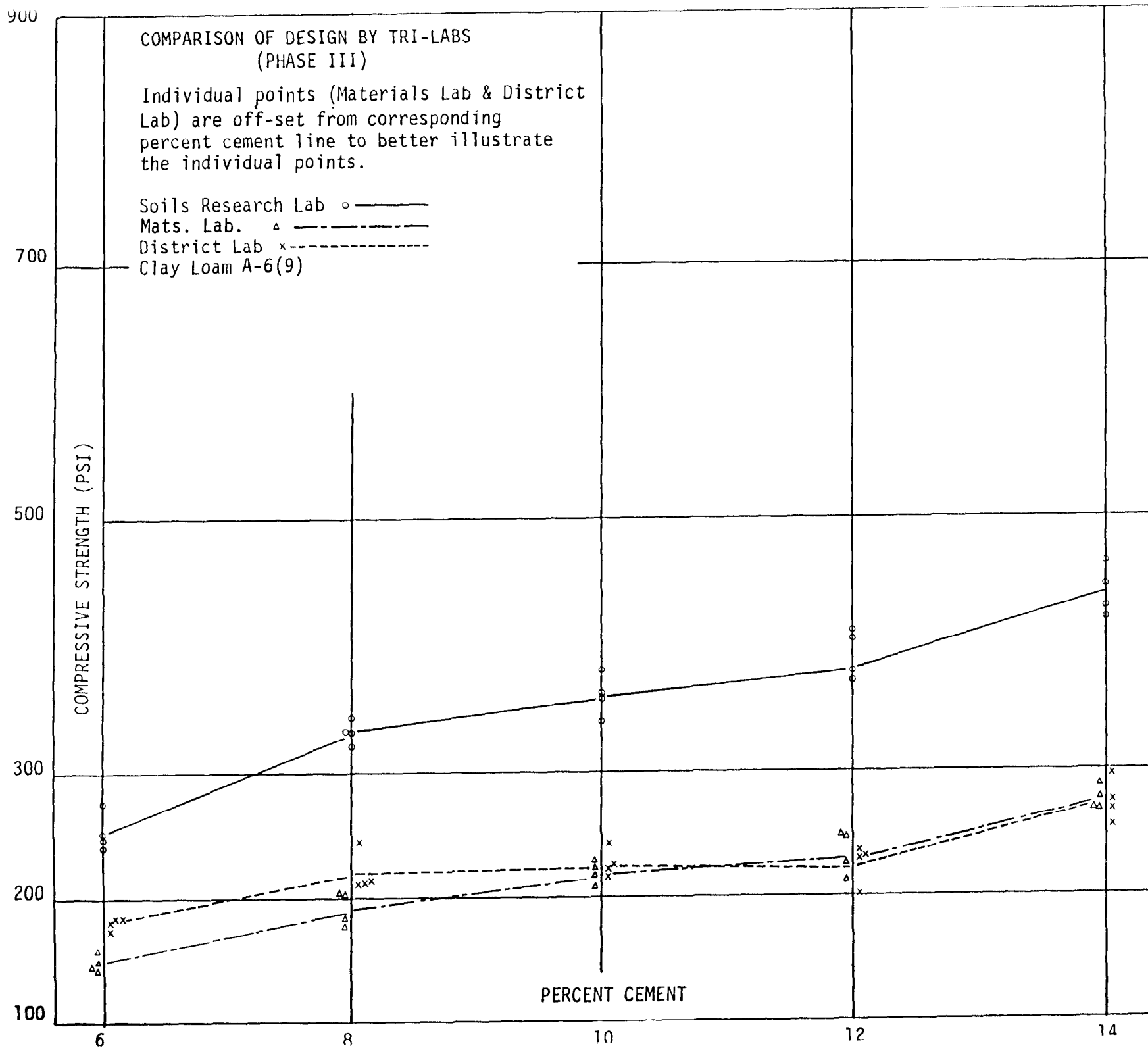

FIGURE 28a
86

FIGURE 28b
87



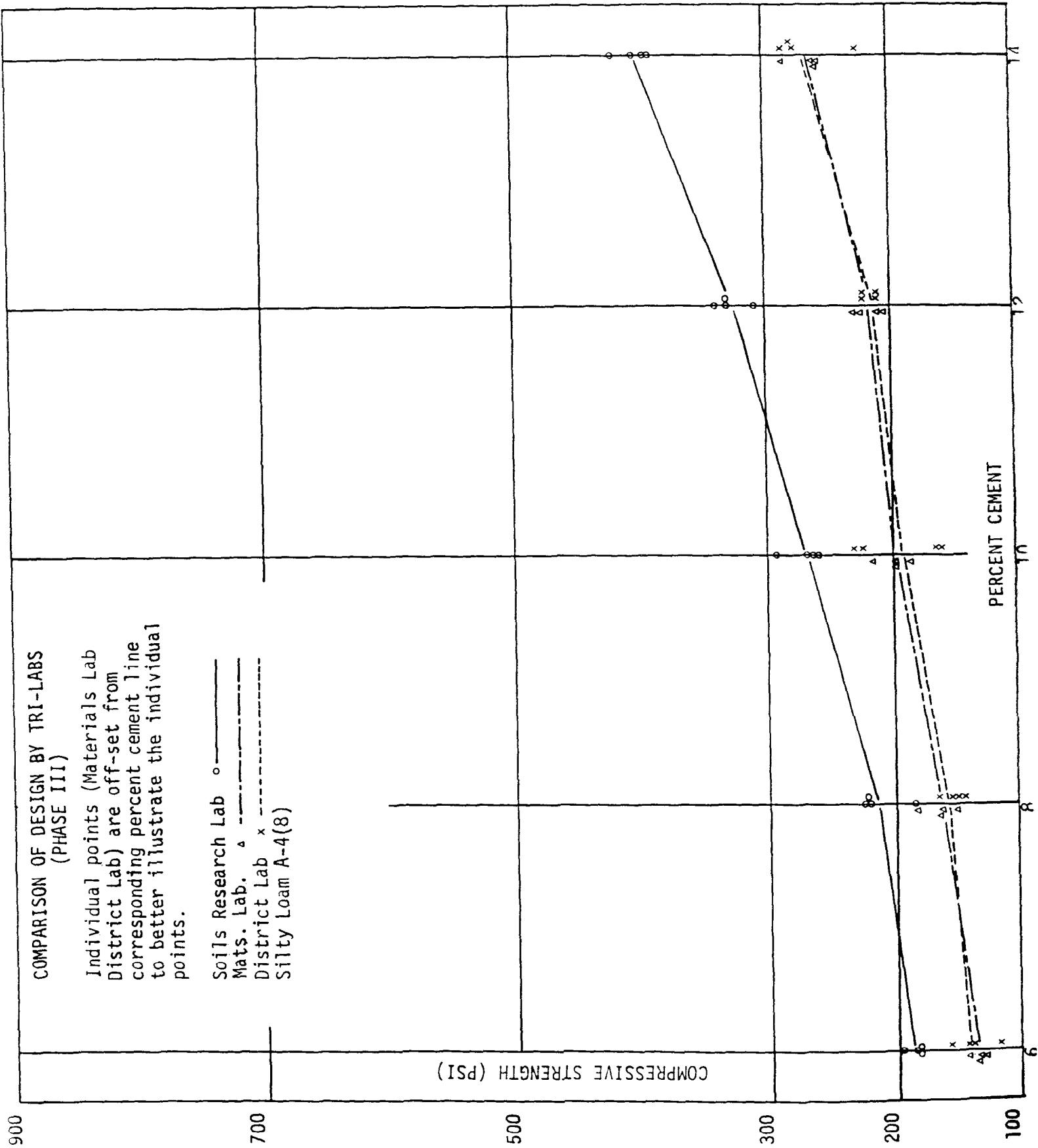

FIGURE 28c

COMPARISON OF DESIGN BY TWO LABS

(PHASE IV)

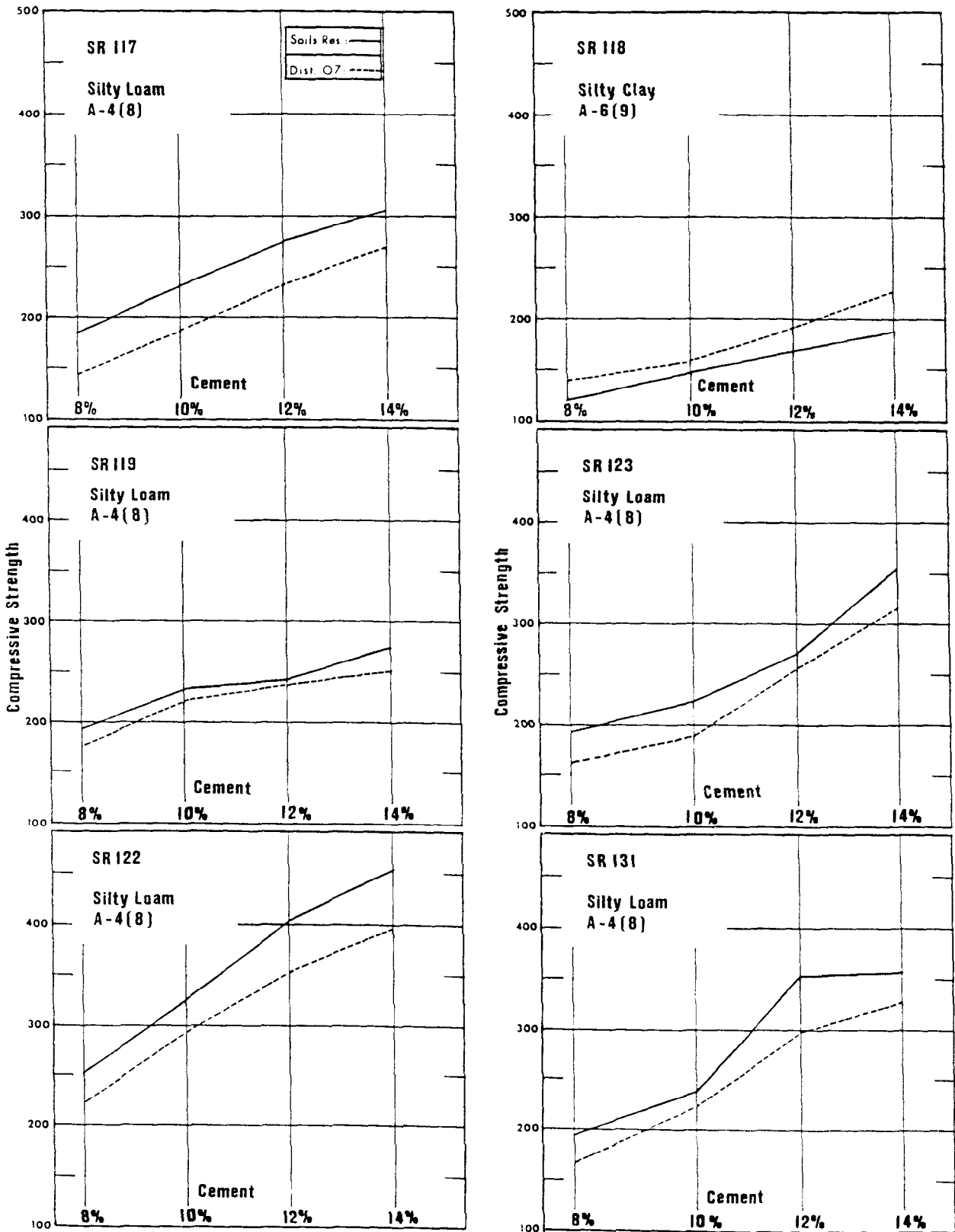
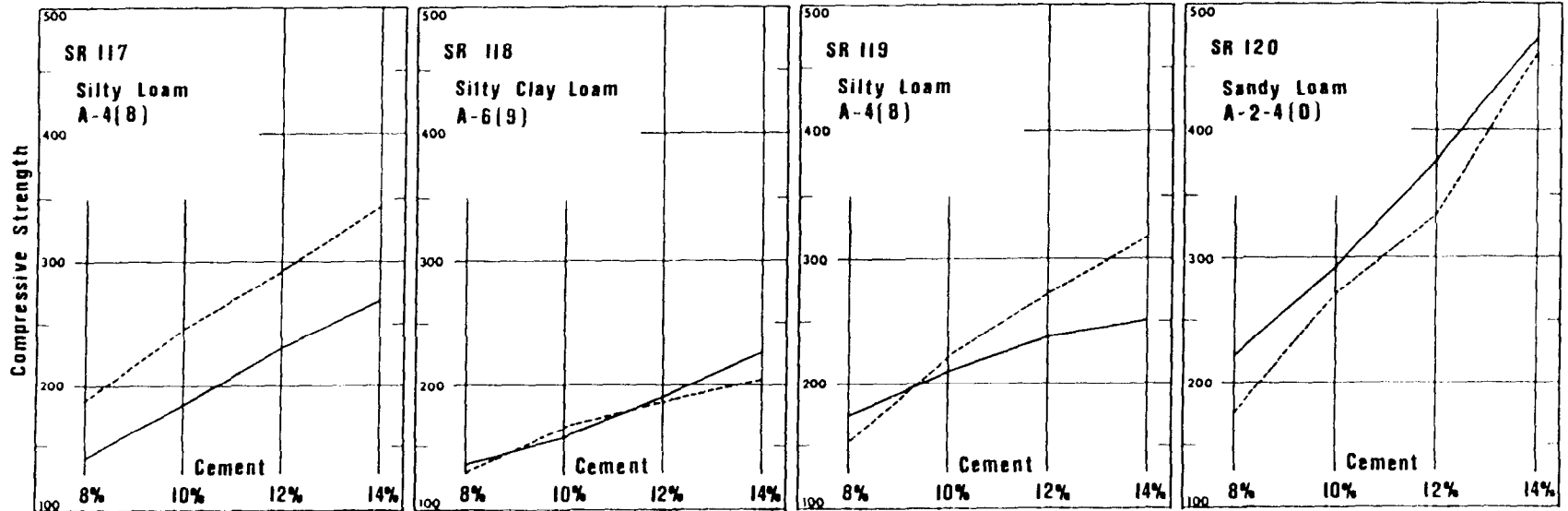

FIG. 29

COMPARISON BY DISTRICT LAB
(TIME A VS. TIME B)



Legend: — Time A
- - - Time B

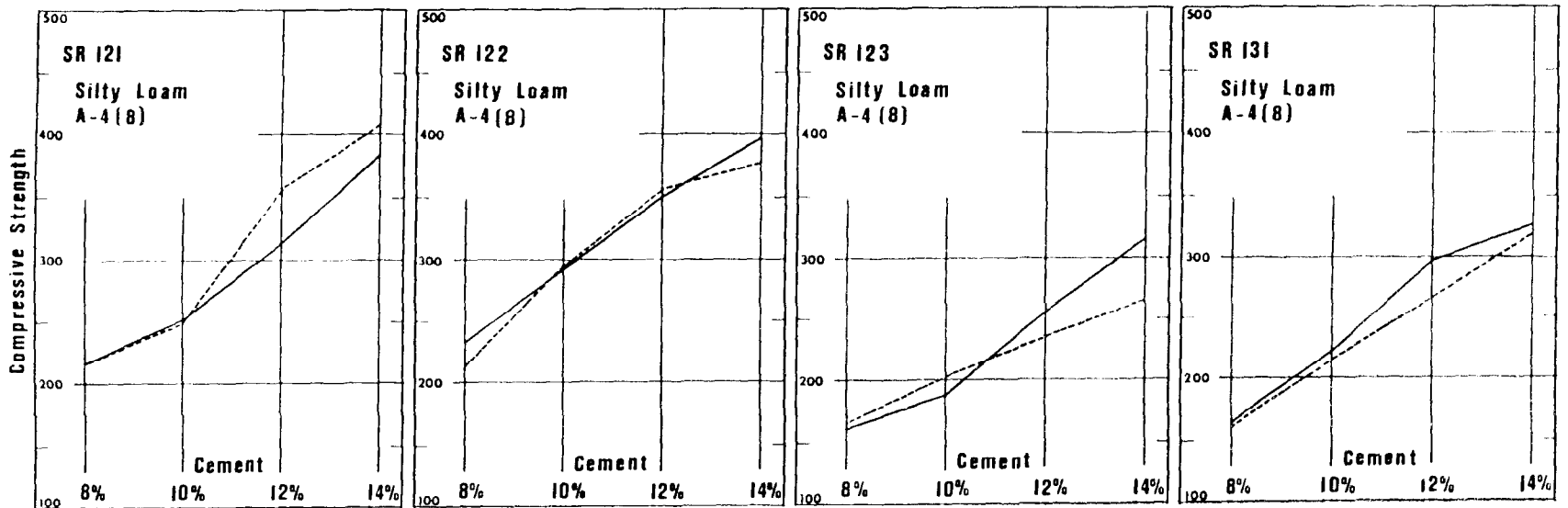

FIG. 30