

# Electrical Safety and Protection

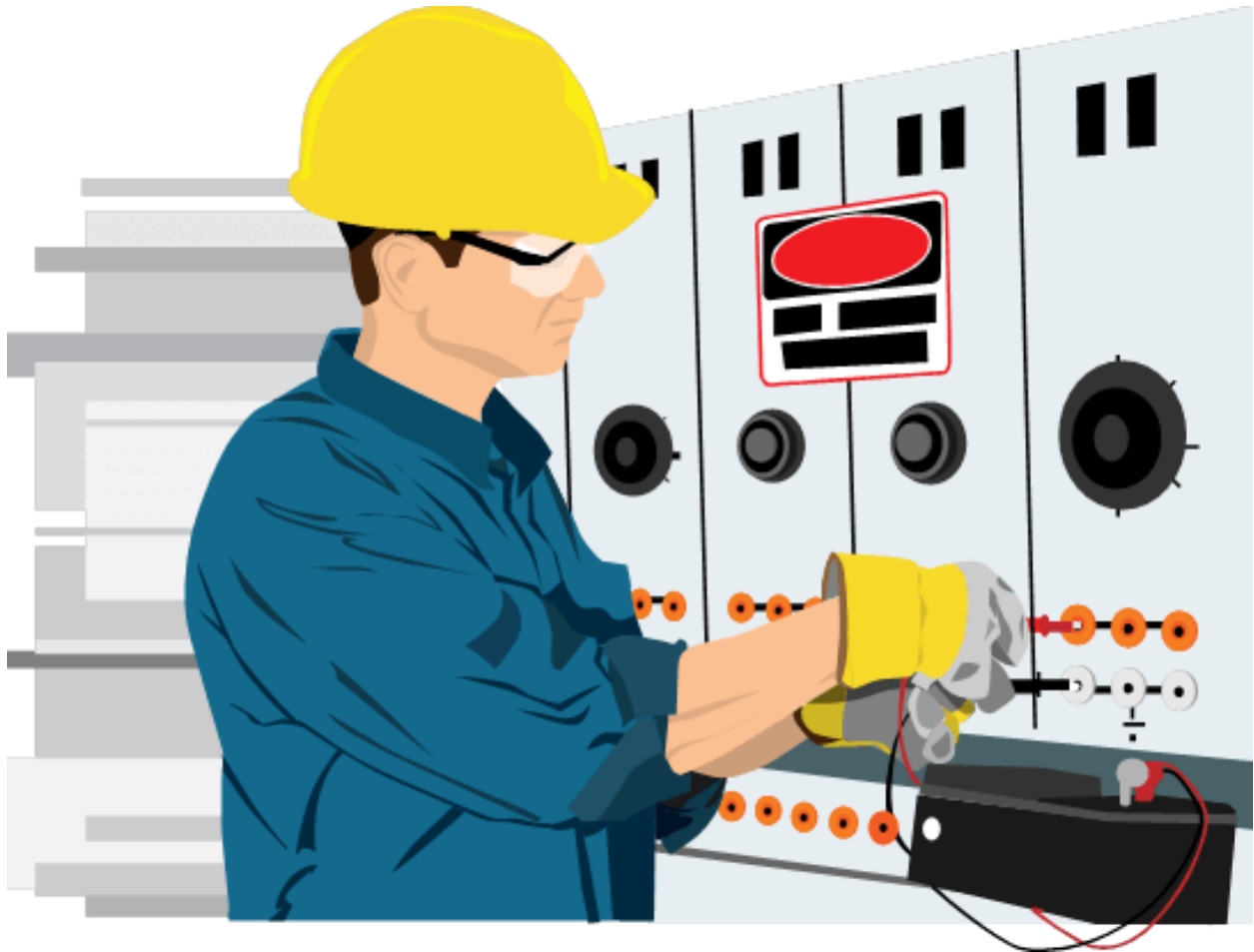

LOUISIANA DEPARTMENT OF TRANSPORTATION AND DEVELOPMENT

LOUISIANA TRANSPORTATION RESEARCH CENTER

TECHNOLOGY TRANSFER AND TRAINING

2019



# TABLE OF CONTENTS

page

Chapter 1: Electrical Hazards.....	5
Chapter 2: Electrical Safety Equipment.....	27
Chapter 3: Electrical Safety Procedures.....	45
Chapter 4: Grounding, Ground Faults, and Short Circuits.....	63
Chapter 5: Fuses and Circuit Breakers.....	87
Chapter 6: Motor Protection.....	113
Answers to Chapter Exercises.....	139

# Chapter 1: Electrical Hazards

## In This Chapter:

The Importance of Electrical Safety

Basic Rules of Electrical Safety

The Electric Circuit

Hazardous Electrical Locations

Electric Shock

Additional Hazards

Electric Arc

## Objectives

After completing this manual, you should be able to:

- List the three main factors that determine the effect of electric current on the human body.
- Explain what to do if a person is a victim of electric shock.
- Name four precautions you can take to guard against electrical shock.
- Define the term *qualified* person.
- Summarize the basic rules of electrical safety.

## Terminology

**Ventricular fibrillation:** A condition in which the heart flutters uselessly and fails to pump blood

**Cardiopulmonary resuscitation (CPR):** A technique used to maintain circulation and respiration

**Electric arc:** A discharge of electricity through a gas

**Qualified person:** A person familiar with the construction and operation of electrical equipment and the hazards involved

**Intrinsically Safe equipment:** The standard unit of frequency, equal to one cycle per second

Electrical safety is important for all workers, but it should be a major concern for the electrical maintenance worker. It is important that you be able to recognize electrical hazards and know how to protect yourself. Prevention is the best way to avoid electric shock, arc, and blast injuries. If you understand and respect electricity, always follow safety procedures, and use personal protective equipment, risk to you and your co-workers will be minimized.

This lesson explains the importance of electrical safety and the possible hazards that exist when working around electricity. It then provides information on equipment use and rules to observe when working with electricity on the job.



## **The Importance of Electrical Safety**

- 1-1 Approximately 1100 people die from electric shock each year in the United States. During your daily routine, you are probably exposed to many potentially dangerous situations involving electricity. Modern life depends on electricity to run machinery, to provide heat and light, and to do many of the jobs people take for granted. Handled with care and respect, electricity is safe and useful, but when handled carelessly, it can be a killer.
- 1-2 Ignorance of safety regulations is no excuse for violating them. In fact, you can be fired from a job for doing so. If you are unsure about the meaning of a rule or how to follow a procedure, ask your instructor or supervisor for help.
- 1-3 Keep in mind that accidents seldom "just happen". In most cases, they are the result of unsafe acts rather than unsafe conditions. Common causes include fatigue, stress, carelessness, or ignorance. If you have an accident while on the job, notify your supervisor and the plant medical department. You should also report any unsafe condition or near-accident promptly.

## The Electric Circuit

- 1-4 Many of you are probably familiar with the theory of electricity. Some of you, however, might benefit from a review of some basic principles. The following paragraphs cover points that are important to your understanding of electrical safety.
- 1-5 Electricity flows through a conducting path in much the same way that water flows through a pipe. This path is called a *circuit*. *Current* is the amount of charge carried by the electrons flowing past a given point in a given time. Energy is required to move the charge through a conductor. The energy that moves the charge comes from a generator or battery. The source does not produce any electrons. It only supplies the energy to move the electrons that are present much the same as pressure supplies the energy in a piping system. As the electrons move through a conductor, they encounter resistance and lose energy. The loss in energy, per unit of charge, is measured in *volts (V)*.
- 1-6 In a simple electric circuit, electricity is delivered to a lamp or other device through a wire, often called the *hot wire*, and leaves through a wire that is connected to the ground. These two wires complete the circuit. A third wire, called a *grounding conductor*, connects the metal housing of the device to the ground to prevent it from being energized. Electrical wires are coded by standard colors of their insulation. A hot wire is either black or red. A neutral wire is white or gray. The grounding wire is green or green with a yellow stripe. Figure 1.1 shows these wire colors in a simple circuit.

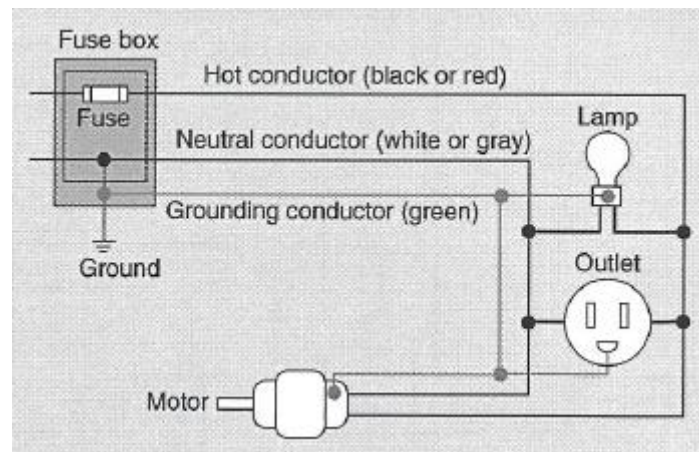

**Figure 1.1: Grounded Electric Circuit**

- 1-7 An open circuit cannot conduct current. When you turn off a switch or disconnect a line cord, you create a gap in the conducting path of the circuit. When the gap is closed, the circuit is said to be closed. If your body closes the gap, you become part of the circuit.
- 1-8 Every complete path in a circuit can conduct current. The amount of current depends on how much resistance is in each path of the circuit and on the voltage of the source. Electric current is measured in amperes (A) and milliamperes (mA). A milliampere is one one-thousandth of an ampere.

## The Electric Circuit (continued)

- 1-9 A circuit that supplies 2 A to a soldering iron and 5 A to a grinder must supply a total of 7 A. The current is divided as shown in Figure 1.2. If an electric heater is added to the circuit and it draws an additional 10 A, the total current increases to 17 A. The larger current due to the additional load will blow a 15 A fuse in the circuit.

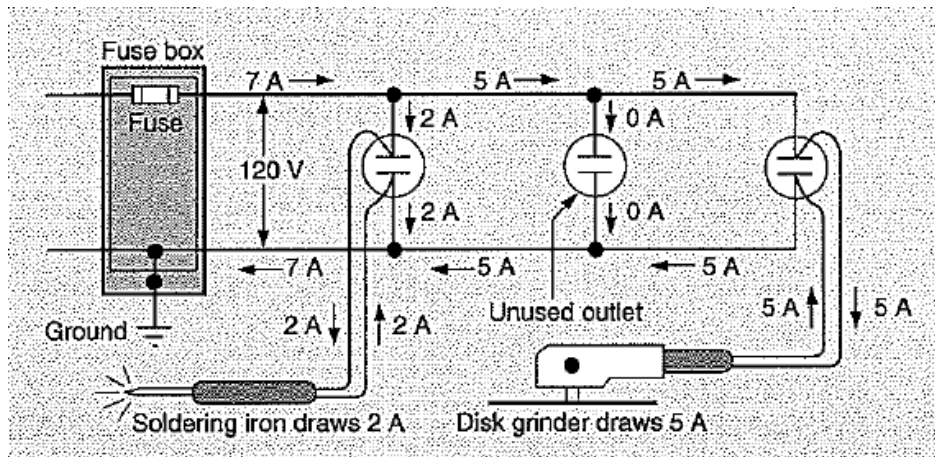

Figure 1.2: Every Complete Path Can Conduct Current

- 1-10 Electric circuits are described by their voltages and by their current capacity. The most common voltages for homes are 120 V for lights and small appliances, and 208 or 240 V for electric ranges, clothes dryers, and air conditioners. The most common voltages for industrial plants are 120, 208 and 240 V for small appliances and 480 V for motors and other equipment. Other voltages are also used in plants.
- 1-11 The 120 V circuits usually have current capacities of either 15 or 20 A, although 30 or 40 A circuits are possible if large enough wires are used. The 240 V circuits usually have capacities of 20 to 70 A. The 480 V circuits have capacities of 20 to hundreds of amperes. In all circuits, the size of the wire used depends on the current the circuit must carry. The wire size does not depend on the voltage of the circuit.



## Electric Shock

1-12 When working with any electric circuit, you are always exposed to the potential for shock. Some shock hazards are obvious such as:

- Assuming a circuit is dead without testing or testing it with your finger to see if it is live
- Using an electric tool that gives you a tingle when you touch it
- Using a device with a frayed cord or a cracked plug

Other shock hazards, however, are not so obvious. Avoiding shock hazards requires regular inspections, good preventive maintenance, and common sense. You should have a healthy respect for all electrical equipment. Always follow safety procedures and use the required personal protective equipment.

1-13 Electric shock occurs when current passes through the body. The effect of the current on the human body depends on several factors:

- The amount of current passing through the body
- The path of the current through the body
- The length of time the body conducts the current

Secondary factors include age, size, physical condition, and the frequency of the current (AC is slightly more dangerous than DC).

1-14 You can receive a shock or burn from any common electric circuit. The current needed to cause a serious or fatal injury is a small fraction of an ampere. An ordinary 120 V circuit can deliver 20 A of current or more before the circuit breaker trips or the fuse blows. This current is many times the amount that can kill a person.

1-15 When current passes through the human body, the effect can range from a mild tingle to death. Even a small and harmless shock can startle you and make you pull back suddenly, sometimes striking something or falling from a height. An electric shock is particularly dangerous when you are unable to let go of the source of the shock and the current tightens your chest muscles so that you cannot breathe. Other results of shock are burns and severe internal bleeding.

1-16 Electric current affects different body parts differently. For example, 30 mA can paralyze the diaphragm, making breathing impossible. A current as low as 75 mA can affect the rhythm of the heart. Current can also cause severe burns. Table 1-1 is a list of the kinds of damage small currents can cause in the human body.

**Table 1-1: Effect of Alternating Electric Current on the Human Body**

Milliamperes	Effect
1 or less	Shock Probably is not even felt
1 to 3	Shock is felt but is not painful
3 to 10	Shock is painful. Individual can let go at will because muscular control is not lost.
10 to 20	Some individuals cannot let go at will because muscular control is lost.
20 to 75	Individual cannot let go and breathing is difficult or impossible

75 to 4000	Possible ventricular Fibrillation of the heart causing death. Severe muscular contraction and nerve damage.
Over 4000	Possible heart paralysis and/or severe burns.

## Electric Shock (continued)

1-17 Most fatal shocks occur when the current passes through or near the heart. If the path is through both arms, or through an arm and a leg, as shown in Figure 1.3, the current passes through the chest and near the heart. A current of 100 mA that passes through the heart for only one-third of a second can cause *ventricular fibrillation*, a condition that causes the heart to flutter uselessly and blood circulation to stop. Unless the heart returns to its normal beat and blood flow resumes quickly, the brain is damaged and a short time later the victim dies. Restoring a normal heartbeat usually requires immediate use of special equipment by a trained medical technician. Such assistance is often not available soon enough to help the victim.

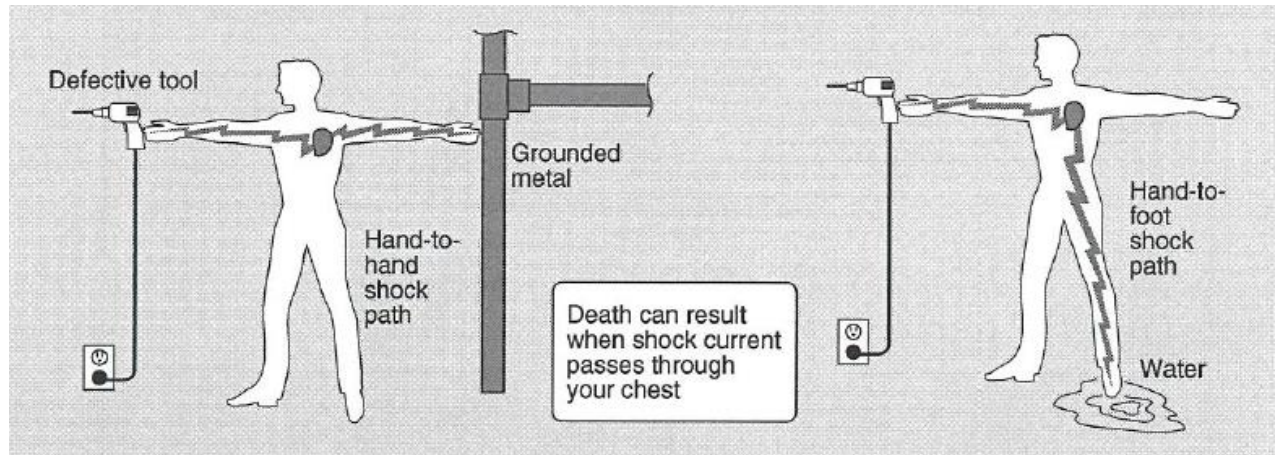

**Figure 1.3: How Electric Shock Reaches the Heart**

1-18 Although shocks over 200 mA are not necessarily fatal, these more severe shocks cause the chest muscles to contract so hard that they stop the heart completely. If this severe shock does not last too long, first aid measures sometimes can be used to restart the heart.

1-19 If a person becomes the victim of electric shock, prompt and proper first aid can mean the difference between life and death. Sufficient circulation can sometimes be maintained by heart compression, which should always be supported with mouth-to-mouth resuscitation. This combination of treatments is commonly known as cardiopulmonary resuscitation (CPR). First aid and CPR are covered in Lesson Three.

1-20 Your body can become part of an electric circuit in the following ways:

- When you contact the hot and neutral conductors at the same time. In this situation, your body is like a light bulb filament or the windings in a motor. It becomes a current path between the wires.
- When you contact a hot conductor while you are in contact with the ground or a grounded structure. This unintentional grounding is described in more detail in Lesson Four.
- When you contact two hot wires with different voltages on them.

- When a ground fault occurs. This situation occurs when a hot conductor touches the metal housing or frame, causing it to become energized. If you are touching the metal housing when it becomes energized and another part of your body is in contact with ground, you will receive a shock.

## Electric Shock (continued)

1-21 The path of least resistance always conducts the most current. Table 1-2 on the following page gives some typical electrical resistances. As you can see from Table 1-2, electrical resistance varies widely between materials and within the human body.

<b>Material</b>	<b>Resistance in Ohms</b>	<b>Current Produced by 120 V</b>
<b>Wood</b>		
1-inch dry	200,000 to 2 Million	0.6 to 0.0006 mA
1-inch wet	2000 to 100,000	60 to 1.2 mA
<b>Metal</b>		
1000 feet of No. 10 copper wire	1	120 A
<b>Human Body</b>		
Dry skin	100,000 to 600,000	1.2 to 0.2 mA
Damp skin	Down to 1000	Up to 120 mA
Wet skin	Down to 150	Up to 800 mA
Hand-to-foot	400 to 600	300 to 200 mA
Ear-to-ear	100	1200 mA

1-22 Three factors determine electrical resistance:

- **Physical size of the substance.** Resistance varies directly with length, and inversely with cross-sectional area.
- **Properties of the substance.** Some substances conduct electricity easily. Others offer great resistance to the flow of electrons.
- **Purity of the substance.** Pure water does not conduct electricity. Small amounts of dissolved minerals and salts, however, make water a good conductor. Perspiration contains salts and minerals, and therefore increases the ability of the human body to conduct electricity.

1-23 Dry, nonmetallic materials generally resist electricity well. However, these same materials become better electrical conductors if they become damp. This rule applies to your body as well. Dry skin has greater electrical resistance than wet skin. Therefore, your body will conduct less current if your skin is dry. However, if a body becomes part of a high-voltage circuit, the skin may be punctured. The current is then limited only by the internal resistance of the body, and the current is much higher because of lower resistance.

1-24 When the skin is dry, the shock from a 120 V circuit might be less than 1 mA. Consequently, it produces little or no sensation. But even a small amount of perspiration or moisture greatly reduces the skin's resistance. When

skin is moist, a 120 V circuit can produce a deadly shock. A person standing in water or leaning against a wet object can receive a shock of 800 mA—far above the lethal level.

## Electric Shock (continued)

1-25 You can take several precautions to guard against electric shock:

- *Insulation* provides electrical separation between you and the conductor.
- *Grounding* provides a low-resistance electrical path to earth.
- *GFCIs* detect current leaking to ground and turn off the circuit.
- *Lockout* prevents a circuit from being energized while you are working on it.

These and other safeguards are covered in detail in later chapters.

## Electric Arc

1-26 An *electric arc* is a discharge of electricity through a gas. Electric arcing most often occurs when two conductors in an electric circuit are separated. For an arc to form, enough electrical energy must be available to maintain the current through the separation. Air itself cannot conduct current. It is vaporized material at the arc terminal and ionized particles of air that actually conduct the current. The mixture of materials through which the arc travels is called plasma.

1-27 Electric arcs are extremely hot and can cause serious burns. They can ignite clothing and cause fatal burns from a distance of several feet. The closer you are to the arc and the longer you are exposed to it, the more severe your injuries will be.

1-28 Electric arcing can also cause an increase in pressure that can cause violent explosions and send bullet-like fragments and molten metal flying. These blasts can be so powerful that they can blow out walls. Eye damage, severe burns, and many other injuries can be the direct result of these explosions. Whenever there is the possibility of an electric arc, you should:

- Wear appropriate face, eye, and ear protection
- Wear flash resistant clothing
- Maintain as much distance as possible between yourself and the potential source of the arc.

## Basic Rules of Electrical Safety

- 1-29 To avoid the hazards of electric shock and arcing, safety must be planned into every job. If you are not sure how to perform a certain task (or how to perform it safely), ask your supervisor or an experienced fellow worker. Never take chances that could endanger you or others.
- 1-30 The Occupational Safety and Health Administration (OSHA) has established procedures or *standards* for working safely with or near electrical equipment and wiring. OSHA standards differ from all other industry standards in that they are enforceable under United States law. All workers should follow these procedures, whether or not they are qualified persons. The National Electrical Code (NEC) defines a *qualified person* as "one familiar with the construction and operation of the equipment and the hazards involved." All electrical installation and repair work in a plant should be performed by, or under the direction of, a qualified person and should follow NEC installation and design standards.
- 1-31 **Clothing:** Wearing the proper clothing and protective equipment when working around electricity can help you work safely. Some basic rules follow:
- Do not wear rings, watches, or any metal jewelry or ornaments. Not only can these articles come into contact with electric circuits, they can become caught in moving machinery.
  - Wear a non-conducting, plastic, ANSI Class G or E hard hat (formerly Class A or B).
  - Wear safety glasses.
  - Wear shoes with non-conducting rubber soles.
  - Wear heavy cotton clothing. In the event of an explosion or fire, clothing made of polyester or other synthetic fabrics can melt onto your skin and cause serious burns.
  - Even if the power is locked out, wear protective equipment (insulating gloves and sleeve covers) if there is any chance of it becoming inadvertently re-energized. To protect yourself against arcing, wear flash/flare resistant clothing, a flash suit, eye protection, and a face shield.
- 1-32 **Equipment:** The precautions that follow apply to equipment and tools used on or near electric circuits:
- Use the proper devices and tools for the job. Examine safety devices before using them to make sure they are in good condition. Examine all electric power tools and other electrical equipment for signs of damage or wear. Never use faulty power tools. When tools or their cords are damaged, replace them at once.
  - Use insulated tools rather than non-insulated tools when working on electrical equipment. Use only intrinsically safe or explosion-proof tools and hand lamps in hazardous locations. In metal tanks, use 6 or 12 V equipment.
  - Keep all electric machinery free of dust, dirt, oil, and stray tools and parts. Do not store your lunch, tools, or anything else in switch boxes.
  - Where appropriate, make sure all equipment meets the requirements of a recognized testing laboratory. Underwriters Laboratory (UL) and Factory Mutual (FM) are the two best-known certifying agencies.
  - Never overload a circuit, even when all equipment is laboratory-certified.
  - Do not clean or repair machinery while it is in motion without specific directions from your supervisor, or unless precautions have been taken to allow you to do the work safely.
  - Do not use metal ladders near electricity.





## Basic Rules of Electrical Safety (continued)

- 1-33 **Enclosures:** Keep electrical enclosure doors secured and locked. Industrial and commercial enclosure doors are often hinged and held closed with a latch that allows for the use of a padlock. In addition to the latch, equipment doors are sometimes held closed with screws or bolts that help hold the door closed if an internal explosion occurs. For your safety, it is important that door screws be tightened when equipment is energized, as shown in Figure 1.4.



**Figure 1.4: Electrical Enclosure Door**

- 1-34 Circuit breakers or disconnect switches should be opened or closed only when equipment doors are secured (closed and bolted). When you open or close a circuit with a circuit breaker or disconnect, there is a possibility that a circuit fault might exist, causing an overload, arcing, and/or explosion. Therefore, when opening or closing a circuit, be alert, wear protective equipment, stand to the side of the switch as much as possible, and operate the switch with a quick positive motion.
- 1-35 **Wiring:** Wires with damaged or deteriorating insulation must be replaced. Only in an emergency should a wire be wrapped temporarily with electrical tape. As a general rule, wiring jobs for a qualified electrician.

## Basic Rules of Electrical Safety (continued)

- 1-36 **Water:** Water and electricity make a deadly combination. Check your work area for puddles and wet surfaces. Do not energize electrical equipment when it is wet or damp with condensation. If equipment is stored outdoors in cold weather and brought indoors for use, make sure that all condensation has evaporated from the insulation before the equipment is used. If electrical equipment is wet, dry it in the sun or in a warm, dry room. If heat is applied for drying, the temperature should be limited to 200°F. De-energize all electrical equipment in the area before attempting to extinguish a fire with water. Do not try to put out an electrical fire with water. Use only an extinguisher designed for electrical (Class C) fires.
- 1-37 **Lockout:** If the unexpected start-up of equipment is likely to endanger people, you must lock out power to the equipment. When equipment is to be worked on, each worker involved should have his or her own padlock to lock out power. If you will be working on a motor control center, for example, use a lockout device like the one in Figure 1.5. You must have a lock for every power source supplying the electrical equipment. Figure 1.6 on the following pages shows two possible lockout locations. Lockout/tagout procedures are covered in greater detail in Lesson Three.



Figure 1.5: Lock Out Power Before Working on Equipment

## Basic Rules of Electrical Safety (continued)

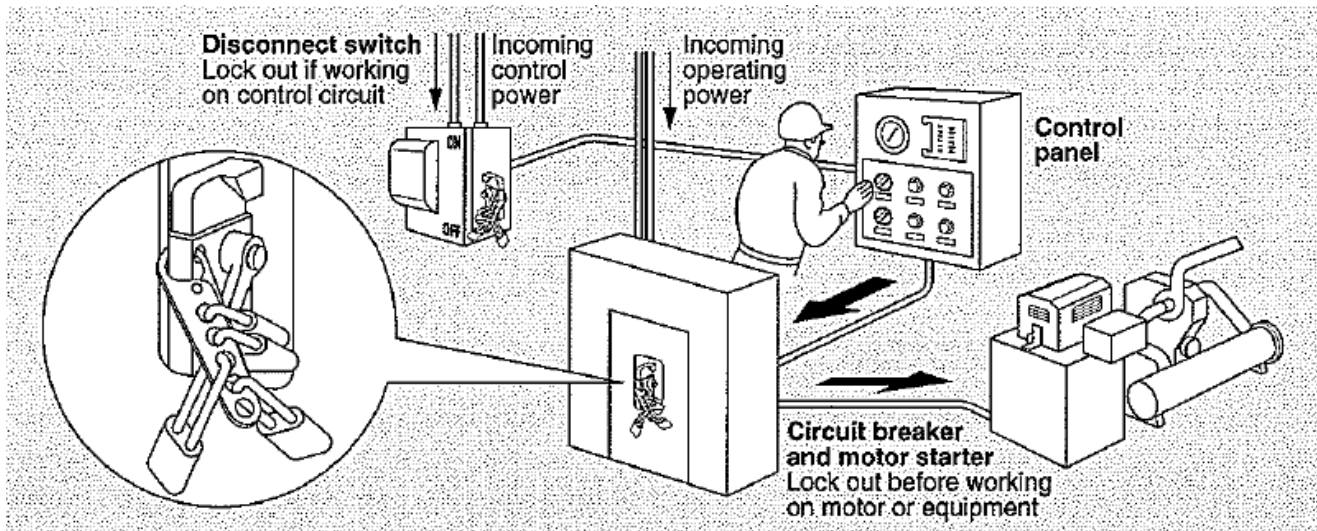

Figure 1.6: Lock Out Every Power Source

- 1-38 Even when the power is locked out, wear protective equipment and use insulated tools. To prevent an accident, treat dead circuits as though they are live. Test every circuit at the point where you will be exposed before starting work. Alert all persons who might be endangered by the work you are doing.

## Hazardous Electrical Locations

- 1-39 If flammable materials or explosive gases are normally present near electrical equipment, special safety measures are needed. In these situations, explosion-proof or intrinsically safe equipment is installed to minimize the hazard. Examples of typical hazardous electrical locations include petrochemical plants, oil-based paint manufacturing facilities, mines, sewers, and grain storage facilities.
- 1-40 *Explosion-proof enclosures* for equipment can contain sparks, high temperatures, and explosions so that the atmosphere outside the enclosure cannot be ignited. For example, gasoline fumes might leak into an equipment enclosure and cause an internal explosion. With an explosion-proof enclosure, however, the explosion is contained inside the enclosure, and no external damage results from the detonation of the explosive atmosphere.
- 1-41 Some electrical equipment is referred to as *intrinsically safe* because it is designed to release only low levels of electrical energy. This kind of equipment cannot cause an explosion or fire of the specific hazardous material.
- 1-42 Explosion-proof and intrinsically safe electrical equipment is usually designed, selected, and installed for a particular hazardous condition that is expected at a location. This equipment must be installed, used, and maintained with care, or the hazard will remain and the equipment will not be safe to use. If an accidental leak or spill occurs during use, for example, the hazardous material can escape into unexpected areas where general-

purpose electrical equipment is installed. Special precautions then must be taken to turn off the electric power without igniting the liquid, gas, dust, or other material.

## Additional Hazards

- 1-43 **Confined spaces:** A *confined space* is an area that has poor natural ventilation and is not designed for occupancy by workers on a continuous basis. Although work in a confined space is not a common part of the workday for most electrical maintenance workers, deaths involving confined spaces occur all too frequently. The information in this lesson offers only brief guidelines. The full OSHA guidelines are much more extensive. As a general rule, never enter a confined space without following the complete OSHA required procedure.
- 1-44 The most important safety consideration for workers in a confined space is the atmosphere within the space. Not only must there be enough oxygen to support life, but the atmosphere must not be flammable, toxic, or explosive. Although testing the air in confined spaces is important, mechanical ventilation is also needed to maintain a safe atmosphere.
- 1-45 **Lifting:** When performing electrical work, it might be necessary for you to do some heavy lifting. If at all possible, use material-handling equipment. Use your muscles only as a last resort. Make sure you know your own limits and know how to lift safely. Many workers have been seriously injured while lifting too much or lifting improperly.
- 1-46 **Fire:** Everyone should take every precaution possible to prevent fires. Fires can be started by burning cigarettes, combustible trash, careless use of matches, improperly installed electrical equipment, or improper storage of oily rags or gasoline.
- 1-47 Become acquainted with the location and operation of all fire-fighting equipment within your work area. In case of a fire, first consider the safety of the people in the plant. Next, make sure you report the fire. Only after everyone is safe and the fire has been reported should you become concerned about saving property. Do not attempt to save property if doing so will endanger your life.
- 1-48 **Falls:** Falls from any height can be dangerous. Working surfaces covered with dust, oil, or grease are dangerous at ground level. Your job might require you to work on walls, ceilings, roofs, or other elevated areas. Falls can be far more dangerous at raised elevations. Falls rank second only to motor vehicle accidents as the most frequent cause of fatal injuries in the United States.
- 1-49 When working at heights, you must consider not only your own safety but the safety of others. Dropped tools or materials can do great damage below. Place signs and barricades to warn others of the danger of falling objects.
- 1-50 Do not overreach when you are on a ladder. Get down and move the ladder to a better position, if necessary. Reaching too far to the side can cause a portable ladder to shift and fall. Keep your hips in position over the ladder so that your center of gravity is always over its base. Never use a metal ladder when working with electricity. Use extreme care when handling or using any ladder near electricity.
- 1-51 **Moving parts:** At some time, you will probably be required to work near moving machinery. Become familiar with the safety rules involving the guarding of moving parts. Make sure that all guards are in place before you start work. Barriers are placed around a job for your protection. Respect them. If you must work near the moving equipment, turn off the machine and lock out the power.

## Additional Hazards (continued)

- 1-52 **Noise.** Because noise seldom causes pain, most people do not realize just how sensitive their ears are to loud noises. Noise is measured in decibels (dB). In a very quiet room, a person with good hearing can just barely hear a sound measuring 1 dB. In the average factory, the noise level measures 80 to 85 dBs. You can stand this level of noise for 8 hours without damaging your hearing. But if you work longer hours or if the noise level is greater than 85 dBs, you need to protect your hearing. A typical punch press measures over 100 dBs. At 110 dBs, sound becomes painful to the normal ear.
- 1-53 Earplugs and earmuffs are commonly used to protect hearing in noisy work areas. Some earplugs are disposable and are made of fiber or foam that fits into the ear canal. Reusable plugs are made of soft rubber or plastic. Earmuffs are designed to fit over the entire ear. The outsides of the earmuffs are hard, cup-shaped shells. They are lined with material that absorbs sound and sealed around the edges with a soft, cushioning material. They are mounted on an adjustable headband that fits over the head (or under the chin when worn with a safety hat).

## Chapter 1 Exercise

Circle the appropriate letter next to the correct answer.

1. In electrical equipment, the grounding wire is usually \_\_\_\_\_.
  - a. Black
  - b. Green
  - c. Red
  - d. White
  
2. The amount of current a circuit can conduct and hazards depends on the voltage of the source and on the \_\_\_\_\_.
  - a. Location of the grounding wire
  - b. Number of current paths
  - c. Power rating of the connected drive
  - d. Resistance of the conductor
  
3. An electric current as low as \_\_\_\_\_ mA can affect the rhythm of the heart.
  - a. 25
  - b. 50
  - c. 75
  - d. 100
  
4. When your skin is dry, it has \_\_\_\_\_.
  - a. Less resistance than when wet
  - b. Greater resistance than when wet
  - c. No resistance
  - d. The same resistance as when wet
  
5. Electric arc is a discharge of electricity through a \_\_\_\_\_.
  - a. Gas
  - b. Grounding wire
  - c. Human body
  - d. Metal enclosure

## Chapter 1 Exercise (continued)

Circle the appropriate letter next to the correct answer.

6. The National Electrical Code defines a "qualified person" as someone who \_\_\_\_\_.
- a. Has been on the job a minimum of one year
  - b. Is a supervisor or manager
  - c. Is certified by a testing facility
  - d. Is familiar with equipment operation and hazards
7. When working around electricity, wear clothing made of \_\_\_\_\_.
- a. Cotton
  - b. Nylon
  - c. Polyester
  - d. Rayon
8. When the insulation on wiring is damaged, the wiring should be \_\_\_\_\_.
- a. Replaced
  - b. Stripped
  - c. Taped
  - d. Tested
9. To extinguish an electrical fire, use \_\_\_\_\_.
- a. A Class A extinguisher
  - b. A Class B extinguisher
  - c. A Class C extinguisher
  - d. Water
10. If the unexpected start-up of equipment could endanger you, you must \_\_\_\_\_ before beginning work.
- a. Ground the equipment
  - b. Insulate the equipment
  - c. Lock out the power
  - d. Turn off the power



## Summary

Knowing and following safety rules is a major job responsibility for anyone who works with electricity. If you are ever unsure of a rule or procedure, ask your supervisor.

Electricity flows through a conducting path called a circuit. Current is the amount of charge carried by the flowing electrons. In a simple electric circuit, electricity is delivered through a red or black hot wire and leaves through a white or gray neutral wire. A Third wire, the green grounding wire, connects the metal housing of the device to the ground to keep it from becoming energized. An open circuit cannot conduct current but every complete path in a circuit can conduct current.

When working with electricity, there is always the potential for electric shock. Shock occurs when current passes through the body. The effect of the current depends largely on the amount of the current, the path of the current, and the length of time the body conducts the current. A current of 30 mA can make breathing impossible and as few as 75 mA can disrupt the rhythm of the heart. Prompt first aid and cardiopulmonary resuscitation (CPR) can mean the difference between life and death for a victim of electric shock. Insulation, grounding, GFCIs and lockout can all protect against electric shock. Electric arc is a discharge of electricity through a gas. Electric arcs are very hot and can cause serious burns.

To avoid the hazards of working with electricity, safety must be considered in all your actions when working with electricity. Wear proper clothing and protective equipment. Use the proper tools. Keep electrical enclosure doors secured and replace damaged wiring. Learn and follow proper lockout procedures. If flammable materials or explosive gases are present near electrical equipment, use explosion-proof or intrinsically safe equipment to minimize the hazard.

Other hazards you might encounter, although not specifically related to the electrical work, deserve mention. Use care and follow OSHA guidelines if you are working in a confined space. Become familiar with fire prevention techniques and the location of firefighting equipment. Use extreme caution when working at heights, especially when on a ladder. Finally, protect your hearing from the excessive noise that is often present.



# Chapter 2: Electrical Hazards

## In This Chapter:

Work Clothes

Personal Protective Equipment

Special Body Protection

Foot Protection

Gloves

Head Protection

Eye Protection

Face Protection

Safety Harnesses and Lifelines

Respiratory Protection

Lockout Devices

Barricade Tape

Electrical Tools

Voltage Testers

## Objectives

After completing this manual, you should be able to:

- Describe appropriate clothing and PPE to wear when working with electricity.
- Explain first aid procedures for eyes.
- Describe the devices used to lock out power.
- Tell how to keep personnel out of an area where electrical work is being performed.
- Explain the purpose of a voltage tester.

## Terminology

**PPE:** A condition in which the heart flutters uselessly and fails to pump blood

**Flash suit:** A technique used to maintain circulation and respiration

**Hot stick:** A discharge of electricity through a gas

**Voltage tester:** A person familiar with the construction and operation of electrical equipment and the hazards involved

Just as important as understanding the hazards of a job is understanding how to avoid being injured as a result of such hazards. A wide array of equipment, clothing, gear, tools, and devices is available to the electrician or electrical maintenance worker to ensure their safety on the job. One of your job responsibilities is to learn how to use it. It is also your responsibility to use it consistently and correctly. If a needed item is not available or if you do not understand its use, make sure you talk to your supervisor.

This lesson offers an introduction to the protective equipment you are likely to use on the job—gloves and head, eye, and face protection. It also covers some specialized equipment that you are less likely to encounter

**but should know about—safety harnesses, lifelines, and respirators. Finally, it covers some tools that you can use to protect yourself and your fellow workers on the job.**

## **Work Clothes**

- 2-1 For electrical workers, good quality work clothing that fits well is the basic requirement. Make certain you wear long sleeves to protect your arms. A heavy fabric is best, as it offers some protection from heat as well as from cuts and scrapes. However, you should avoid loose-fitting clothing near moving machinery. The clothing could become entangled in the moving parts and result in serious injury.
- 2-2 When working around electricity, never wear clothing made of nylon, polyester, or certain other synthetic fabrics. In the presence of intense heat, like that from an electric arc, these fabrics can melt onto your skin. All-cotton clothing is a better choice, as it will burn away in the presence of intense heat.
- 2-3 A still better choice for working in areas where electric arcing is possible is a cotton fabric that has been chemically treated to make it flame resistant. Although these fabrics resist sparks and open flames and are self-extinguishing, they offer only moderate protection from heat. The best fabric choices are Nomex, PBI, or similar fabrics. These fabrics do not melt or catch fire and they offer excellent thermal protection. Ask your supervisor which level of protection is right for you in the work you are doing.
- 2-4 All clothing worn in the workplace requires periodic cleaning. Ask your employer how your work clothing should be cleaned and how often cleaning should be done. It is important to follow manufacturer's instructions to preserve thermal and fire-retardant properties of some clothing. Some working conditions might require that your work clothing be left at work for professional cleaning.

## **Personal Protective Equipment**

- 2-5 The workplace can present hazards not normally encountered elsewhere. Some of the control measures for these hazards depend solely on the worker. These control measures are called *personal protective equipment* (PPE). PPE is often used along with other safety control measures so that you are still protected if the other measures fail. Examples include hard hats, safety glasses, gloves, and respirators.
- 2-6 Government safety regulations place several responsibilities regarding personal protective equipment on employers. Your employer is responsible for:
- Identifying the PPE to be worn in the workplace
  - ensuring that the appropriate PPE is worn
  - Ensuring that only approved PPE is used
  - Ensuring that PPE is cleaned and maintained properly
  - Training employees in the purpose, limitations, and proper use of PPE

## **Personal Protective Equipment (continued)**

2-7 You too have responsibilities regarding PPE. You are responsible for:

- inspecting all required PPE for cleanliness and proper function before you use it
- wearing the PPE correctly
- using all the PPE required for the task
- reporting any defects in the equipment.

It is important to remember that your protection depends on proper use of the required equipment.

2-8 Manufacturers of protective equipment provide instructions on how the equipment should be used and maintained as well as a description of the protection it provides. Read and follow the instructions carefully and know the limitations of the equipment.

## Special Body Protection

- 2-9 To protect you and your work clothes, special garments, aprons, and sleeve protectors must sometimes be worn over your work clothes. This protective gear can be made various materials, each of which provides a specific kind of protection and has certain limitations. For example, most special body protection devices used in the workplace to protect you from extreme heat and flame do not provide protection from chemicals. Garments designed for chemical protection usually do not provide protection from extreme heat or flame.
- 2-10 The hazards of a particular task determine what body protection material, design, and construction are needed. Many kinds of protective garments are used in industry, ranging from flame-retardant garments used in welding operations and electrical work to fully encapsulating chemical suits used to handle highly toxic or unknown chemicals. It is important to remember that the hazards of a particular job determine the special body protection required. There is no single garment or device that can protect you in all situations.
- 2-11 When performing electrical work where the danger of electric arc is great, you should wear a *flash suit* made of flame-retardant material as shown in Figure 2.1. Follow the Department rules concerning when it is to be worn. It might need to be combined with additional eye, hand, and head protection. These suits are rated by degrees of continuous ambient temperature. If a suit's continuous ambient rating is 450°F, its short term rating is much higher.



**Figure 2.1: Flash Suit**

## Foot Protection

- 2-12 Because about one in ten disabling injuries to industrial workers is to the feet and toes, a wide variety of protective footwear is available. For example, in areas where there is a danger of falling objects, safety shoes with steel toe boxes and metatarsal guards are common. Flexible metal insoles prevent sharp pieces of metal from entering the sole of a safety shoe and piercing the foot. Workers who must stand or work on hot surfaces wear special soles that do not conduct heat. In wet areas, waterproof shoes or pullover boots help keep the feet dry. On slippery or oily surfaces, nonskid soles help prevent slips and falls.
- 2-13 When working with electricity, specialized foot protection is sometimes required. Electrical workers often wear shoes stitched and cemented without nails to reduce electrical conductivity. These shoes also have an insulating layer sandwiched within the sole. Check with your supervisor to determine what kind of shoe is right for the work you do.

## Gloves

- 2-14 Gloves are commonly used in the workplace to protect hands against cuts, puncture wounds, chemicals, and hot and cold temperature extremes. Just as with special body-protection devices, there are many materials used to manufacture gloves. Glove selection depends on the hazards associated with the job. There is no single glove that can provide protection against all hazards. In fact, sometimes two gloves must be worn at the same time to protect against all hazards involved in a particular job.
- 2-15 When working with electrical equipment, especially if you could come into contact with an energized conductor, wear leather gloves over rubber gloves. Glove combinations, like the ones shown in Figure 2.2, are made especially for this purpose. The rubber offers electrical insulation between you and the conductor. Sometimes these combination gloves include a cotton liner to make the gloves more comfortable.



**Figure 2.2: Combination Gloves for Electrical Work**

## Gloves (continued)

### WARNING

It is extremely important that you inspect rubber protective equipment carefully before using it. Tears, holes, and cracks, can destroy its insulating properties. Rubber gloves should be air tested before each use. To perform the air test, the glove should be inflated, visually examined for holes, and held close to the face to listen and feel for air leaks.

- 2-16 When working in close quarters, in locations where your arms might come into contact with an energized conductor, rubber sleeve covers are sometimes needed to protect your arms from accidental contact with energized conductors. Rubber sleeve covers are available in several voltage classes, styles, sizes, and materials. Your supervisor can help you choose the one that is right for you.

## Head Protection

- 2-17 One of the most common pieces of personal protective equipment is the hard hat. Once made of metal, today's hard hats are made of reinforced plastic, which can offer the advantage of electrical insulation. They have an adjustable headband and suspension webbing, as shown in Figure 2.3. The webbing should provide a 1-inch clearance between your head and the top of the shell. Without this space, a blow from a falling object would be transmitted directly to the skull and could cause serious injury. The webbing also allows air to circulate under the shell. In warm weather or warm work areas, this circulating air helps keep you cool. In cold weather, a liner inside the hat will help keep your head and ears warm.

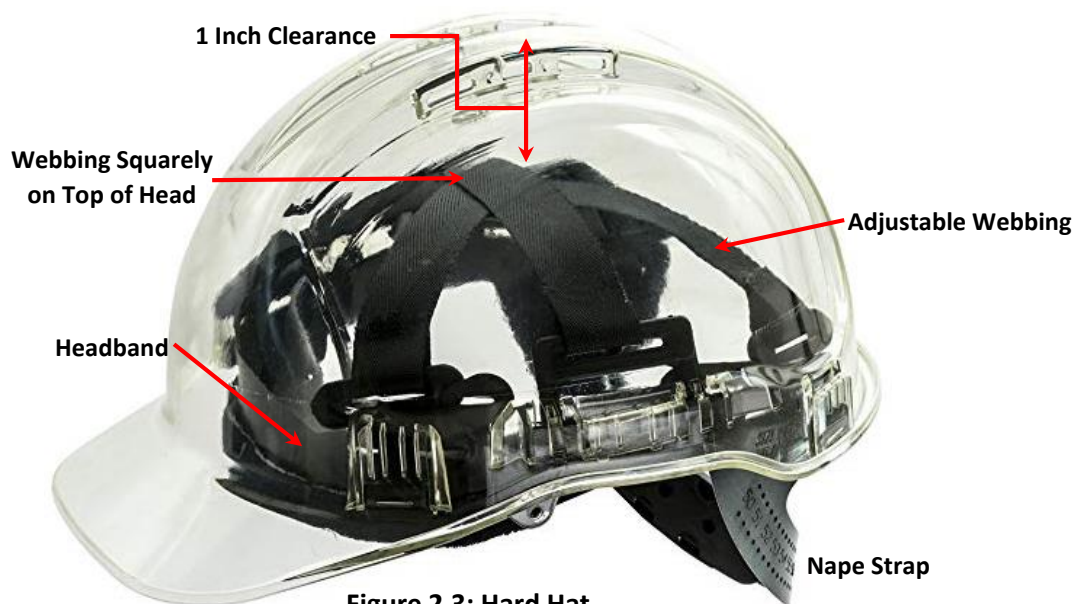

Figure 2.3: Hard Hat



2-18 Check your hat each time you wear it. Examine the shell for dents, cracks, or holes. Inspect the webbing for loose, torn, or defective straps. Do not use the hat if you see anything wrong. Remember, it is the webbing that takes the impact and protects your head. Avoid using harsh cleansers or solvents to clean your hard hat. Instead use only soap and warm water.

2-19 All hard hats are designed to protect your head from the impact of falling objects and other blows. When working with electricity, however, you must choose a hard hat that also provides electrical insulation. The American National Standards Institute (ANSI) has classified hard hats into three classes:

- Class G hard hats (formerly Class A) reduce the hazard of contact with low-voltage (up to 2200 V phase-to-ground) conductors
- Class E hard hats (formerly Class B) are intended for high-voltage (20,000 V phase-to-ground) protection
- Class C hard hats offer no electrical protection

Make sure to select a hard hat that provides the appropriate electrical protection. You should wear a Class G or E hard hat anytime there is a possibility that you could be exposed to mechanical blows or to electric shock, arc, or blast.

## Eye Protection

2-20 Eye protection might seem to be a nuisance. You can probably think of several excuses for not wearing safety glasses or goggles, but an excuse will not prevent blindness. Many electrical workers have suffered severe, permanent eye damage from accidents that occurred while they were not wearing eye protection. All electrical workers should wear eye protection at all times on the job.

2-21 **Safety glasses:** Industrial safety glasses have stronger lenses and stronger frames than everyday eyeglasses. Safety glasses will not shatter as easily as regular glasses if something hits them. When side shields are added, as shown in Figure 2.4A, the glasses also protect your eyes from the sides. Make sure that your safety glasses fit you properly. Wear them up against your face, not down on your nose.



Figure 2.4: Safety Glasses

## Eye Protection (continued)

- 2-22 Safety glasses are also available as prescription glasses. In fact, the only prescription eyeglasses that can be worn in an industrial setting are those approved by ANSI. For additional protection, you can wear prescription safety glasses under safety goggles. Do not wear contact lenses without first checking with your supervisor or safety officer. They can be dangerous in certain situations.
- 2-23 Eyeglass lenses that change their tint with changes in light level are not suitable for use in certain situations. They take a minute or so to adjust, and during that time you will not be able to see well. If tinted glasses are required on your job, ordinary sunglasses are not adequate. Make sure to use glasses with the required protection.
- 2-24 **Safety goggles:** When something can come at you fast (an electric arc, for example) or can splash in your eyes, you must wear safety goggles. Often you cannot see a liquid, spark, or piece of metal flying at you in time to react. Safety goggles offer better protection than safety glasses, because they prevent dust, chips, and liquids from reaching your eyes from any direction. Some goggles offer UV protection, which is important in case of an electric arc. Some typical safety goggles are shown in Figure 2-5.



Figure 2.5: Safety Goggles

- 2-25 The need for safety goggles varies from work area to work area. But the reason for wearing them is always the same which is to protect your eyes from liquid splashes, flying objects, particles in the air, and intense light. In some areas, you are required to wear eye protection even if you are not actively working.
- 2-26 **First aid for eyes:** If foreign particles enter your eyes, do not attempt to remove them. Instead, consult a doctor immediately. Do not rub an injured eye, as this action can cause additional damage. However, there is one kind of eye injury that you should treat immediately on the job. This is an injury caused by chemicals. Strong chemicals act on the eye very rapidly. Such accidents often occur in areas where storage batteries are kept or charged. These chemicals can cause blindness very quickly if they are not rinsed out immediately.

## Eye Protection (continued)

2-27 If your eyes should come in contact with a chemical, you must remove the chemical as quickly as possible. Eyewash stations like the one shown in Figure 2.6 should be available in any work area in which this kind of accident could happen. It is a good idea to locate the nearest station before you start the job. If an eyewash station is not available, you can use a drinking fountain, flowing water from a hose, or even a simple container of clean water in an emergency. Make sure the container is large enough so you can immerse your face.



**Figure 2.6: Eyewash Station**

- 2-28 If a chemical is splashed in another worker's eyes, you might need to lead that person to the nearest eyewash station. Start applying water immediately and continue for at least 15 minutes until the eyes are thoroughly flushed. Call for medical help. Do not attempt to apply a neutralizer. Any such material should be applied only by a doctor after the eyes have been washed thoroughly with clean water.
- 2-29 Use these same procedures if a strong chemical comes in contact with your skin. Use an emergency shower immediately. If your clothing becomes soaked by the chemical, remove it at once.

## Face Protection

- 2-30 A face shield protects your face and neck from flying particles. It also provides some protection against injuries from sparks, sprays, and splashes. Face shields are usually made of transparent plastic and can be raised or lowered as required. Face shields are often worn when machine tools are being operated and when liquid chemicals are being handled.
- 2-31 A face shield alone does not completely protect your eyes, because you might turn your head and allow a spark or splash to reach your eyes. Goggles worn underneath the shield will protect your eyes from this kind of danger. The face shield of a flash suit, like the one shown in Figure 2.1, will protect your face from molten metal and other flying objects.

## Safety Harnesses and Lifelines

- 2-32 A safety harness can save your life if you fall when climbing or working at heights. The safety harness can limit falls and prevent serious injury. For example, if you are in a high place and slip, a commercially available safety harness limits your fall to only six feet.
- 2-33 If your job requires you to enter a tank, boiler, or other confined space, a lifeline should be attached to the safety harness. If something goes wrong, the lifeline is your means of rescue. If you are injured or overcome by gases or vapors, you can be pulled to safety by the lifeline. Confined space entry requires a great deal of specialized training. It is mentioned here only to alert you to the potential hazards.

### **WARNING**

**Never enter a confined space unless you have received special training.**

## Respiratory Protection

- 2-34 Respiratory protection is required for both workers and rescue personnel in a variety of work environments. Although electrical work does not normally require respiratory protection, your job might take you into areas in which respirators must be worn. Such as those containing airborne toxic chemicals and those containing too little oxygen, for example.
- 2-35 Should you be required to use a respirator, you must receive a great deal of additional training on their selection and use. Some respirators remove dust and other harmful particles but are not effective against vapors and gases. In some situations, the atmosphere in an area does not contain enough oxygen to support life and an oxygen-supplying respirator must be used.
- 2-36 Before employees use respirators in a facility, OSHA requires that employers have a written respiratory protection program. In addition, employers must provide employees with medical examinations and specialized training. Do

not use a respirator unless you are medically qualified to wear one, have received appropriate training, and have had the respirator's fit tested. Deaths have occurred during respirator use because these conditions were not met.

## Lockout/Tagout Devices

2-37 To protect yourself and other workers in an area, you must usually lock out and tag the main disconnect switch in the OFF position before working on electrical equipment. Most switch boxes are made so that a padlock can be snapped into place. The lock will prevent the operation of equipment that has been de-energized. The tag identifies the nature of the work in progress and the worker who placed the lock and tag.

2-38 OSHA makes the following requirements regarding tag out devices:

- Tags must clearly identify the employee who applies them. When a tag is attached to an energy-isolating device, it must not be removed except by the person who applied it. Tags should never be bypassed or ignored.
- Tags must be readable and understandable by all employees. They must warn against the hazardous condition that will result if the machine or equipment is energized. Most tags have legends such as DO NOT START, DO NOT OPEN, DO NOT OPERATE, DANGER, etc. An example is shown in Fig. 2.7A, on the following page.
- Tags must be made of materials that can withstand the environmental conditions in which they will be used.
- Tags must be affixed securely to energy-isolating devices so that they cannot be detached accidentally during use.

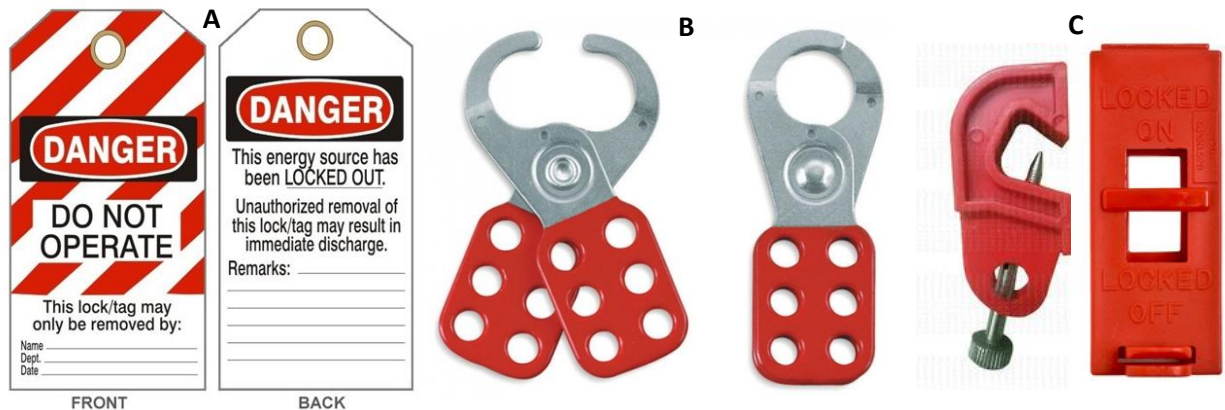

Figure 2.7: Lockout/Tagout Devices

2-39 Several padlocks should be available to every electrician in the plant. If several workers are working on a piece of equipment, a multiple-lock device, like the one shown in Fig. 2.7B, should be available so each worker can attach his or her own lock. Leave your padlock in place until you finish the job. Equipment cannot be restarted until all locks have been removed.

2-40 Your lock should be removable only with its matching key, although a master key is sometimes kept for emergency situations. Remember that installation or removal of a padlock involves taking on responsibility. The main power lockout cannot be reopened until all workers have opened their locks and removed them.

2-41 Devices are also available to lock out circuit breakers and wall switches. These devices are screwed on and lock over the switch and screws. An example is shown in Fig. 2.7C.

### **Barricade Tape**

2-42 In some cases, it is important to keep nonessential plant personnel out of an area where hazardous electrical work is being performed. This is especially true if the job requires the removal of doors or other guards that would normally offer protection.

2-43 In these situations, you should use plastic barricade tape to mark off the restricted area. The tape should be at least 2 in. wide and, according to OSHA specifications, must be red or yellow in color. The tape should be displayed at a level that is readily visible and should enclose the entire danger area. When you complete your work, make sure to remove the tape. Sample tape is shown in Figure 2.8.



**Figure 2.8: Barricade Tape**



## Electrical Tools

- 2-44 Although most hand tools do not seem especially hazardous, using the wrong tool or using a tool incorrectly can be dangerous, especially when working with electricity. Anyone working on or near an energized conductor must use insulated tools. These tools are used just like others, but most of the tool is covered with an electrical insulation to protect the worker from the hazards of electric shock or arc.
- 2-45 Tool maintenance is especially important when working with these tools. Inspect all tools before using them to make sure that they are in good, safe condition. It is especially important that the insulation be undamaged, or the tool's insulating value will be lost. A set of insulated tools is shown in Figure 2.9.



**Figure 2.9: Insulated Hand Tool Set**

**WARNING: Any worn or damaged tool should be removed from service and either repaired or discarded.**

- 2-46 Another kind of tool you should be aware of is the hot stick. Hot sticks are tools used by electrical workers to perform tasks or manipulate conductors from a distance. These devices are simply poles made of an insulating material, usually fiberglass. An example is shown in Figure 2.10. Many models can be fitted with attachments, which allow them to perform a variety of tasks. Attachments include tools and test instruments. If a job situation calls for the use of a hot stick, you should wear protective clothing—at least gloves and eye protection.



**Figure 2.10: Hot Stick**

## Voltage Testers

- 2-47 A voltage *tester* is a simple device. It tells you whether there is a potential difference between two points, but it does not measure the potential difference. In many cases, you will use it to verify that a system has been de-energized and that there is no potential difference. If you need to know the value of a potential difference, you should use a voltmeter.
- 2-48 A commercially available pocket-type voltage tester is shown in Figure 2.11. The pointer moves when the instrument is connected across an AC source. You can carry it in your tool pouch, where it is available for immediate use. It eliminates the need to carry a delicate voltmeter on the job. The potential difference scale on the tester has voltage indication for AC on one side of the pointer and for DC on the other side. The AC scale indicates 120, 240, 480, and 600 V. The DC scale indicates 12, 240, and 600 V.



Figure 2.11: Voltage Tester



## Chapter 2 Exercise

Circle the appropriate letter next to the correct answer.

1. Which of the following is the best choice of work clothing fabric when working with electricity?
  - a. Cotton
  - b. Nomex
  - c. Nylon
  - d. Polyester
  
2. Which of the following is an employee responsibility regarding PPE?
  - a. Ensuring that only approved PPE is worn
  - b. Identifying required PPE
  - c. Inspecting PPE before use
  - d. Maintaining PPE
  
3. The best combination of gloves to wear when performing electrical work is \_\_\_\_\_.
  - a. Leather over rubber
  - b. Leather over cotton
  - c. Synthetic over rubber
  - d. Synthetic over cotton
  
4. Plastic is better than metal as a hard hat material because it \_\_\_\_\_.
  - a. Fits better
  - b. Is stronger
  - c. Keeps the wearer cooler
  - d. Offers electrical insulation
  
5. When should electrical workers wear eye protection on the job?
  - a. At all times
  - b. When changing fuses
  - c. When working with batteries
  - d. When working with energized conductors

## Chapter 2 Exercise (continued)

Circle the appropriate letter next to the correct answer.

6. If foreign particles enter your eyes, you should \_\_\_\_\_.
- a. Ask a nearby worker to remove them
  - b. Consult a doctor immediately
  - c. Rub your eyes gently
  - d. Wash them out
7. Which of the following is a function of the tag on a locked-out disconnect switch?
- a. Give instructions for the work to be performed
  - b. Identify the individual who placed the lock
  - c. List all the affected subsystems
  - d. Prevent accidental startup
8. According to OSHA regulations, which of the following colors is acceptable for barricade tape used to mark off restricted areas?
- a. Black
  - b. Green
  - c. White
  - d. Yellow
9. When working with electricity, it is especially important to inspect tools for \_\_\_\_\_.
- a. Bent shafts
  - b. Cracked handles
  - c. Damaged insulation
  - d. Worn tips
10. Voltage testers are typically used to \_\_\_\_\_.
- a. Cut off power to a circuit
  - b. Distinguish between AC and DC circuits
  - c. Measure potential differenced
  - d. Verify that a circuit is de-energized

## SUMMARY

For electrical workers, long-sleeved garments made of heavy cotton fabric are generally the best choice for work clothing. Avoid synthetic fabrics and loose fitting garments. Your supervisor will inform you if special flame-retardant fabrics are required. Protective clothing, such as sleeve covers or a flash suit, is sometimes required over work clothing. Flash suits are rated by degrees of continuous ambient temperature. Electrical work often requires special shoes, made without metal parts, to reduce electrical conductivity. Leather gloves worn over rubber gloves offer the best protection when working around electricity. Always check the condition of the rubber before using the gloves to ensure its insulating value. Never wear a metal hard hat when working around electricity—wear one made of reinforced plastic. It must be rated ANSI Class G or Class E to provide electrical insulation. Class C hard hats offer no electrical protection. Several kinds of eye protection are available— make certain the one you choose is right for the job. If foreign particles enter your eyes, do not rub them, but consult a doctor immediately. If a chemical splashes in your eyes, rinse them immediately and thoroughly. If a chemical comes in contact with your skin or clothing, shower immediately. Sometimes a face shield is required in addition to safety glasses or goggles.

If your job requires you to work at heights, a safety harness can help prevent falls. When attached to a lifeline, a safety harness can also pull you to safety if you are working in a confined space. In such a situation, a respirator might also be required. You must receive special training before using a respirator.

Every electrical worker in a plant should have one or more padlocks available for locking out power. Other devices are available for locking out wall switches and circuit breakers. Barricade tape can also be used to keep other plant personnel from contact with equipment while work is being done. Keep electrical tools in good condition, especially the insulation on insulated tools. Damaged insulation can decrease the tool's insulating value. Voltage testers are valuable tools. They do not measure potential difference, but indicate whether or not there is a potential difference between two points.



# Chapter 3: Electrical Safety Procedures

## In This Chapter:

Energy Control

Power Tool Safety Rules

Electrical Safety Lockout

Recognizing Electric Shock Victims

OSHA Lockout/Tagout Procedures

First Aid for Shock Victims

Using Power Tools Safely

The ABCs of CPR

## Objectives

After completing this manual, you should be able to:

- Explain the concepts of energy control and zero energy state.
- Summarize the OSHA lockout procedure.
- Explain how portable power tools are grounded.
- List some common symptoms of electric shock.
- Summarize the steps involved in administering CPR.

## Terminology

**Energy control:** The management of electricity and stored mechanical energy in a system

**Zero energy state:** A condition in which it is impossible to activate a machine accidentally

**Functional insulation:** Ordinary electrical insulation

**Protective insulation:** Additional insulation independent of functional insulation

**Cardiopulmonary resuscitation (CPR):** An emergency procedure used to restore respiration and circulation

The electricity that runs equipment and machines can be dangerous, especially if it is not carefully controlled during maintenance and servicing. OSHA has established specific procedures for safeguarding against accidental electric shock (lockout/tagout) as well as for safe shutdown, release of stored mechanical energy, and equipment startup. OSHA also requires periodic employee training in these procedures.

This chapter covers not only energy control, but also the safe use of portable power tools and emergency procedures to follow in the event of an electric shock accident. This chapter is meant to serve only as an introduction to these important topics. Much of your training in these areas will be specific to your job and will be based on the types of equipment it contains and the specific procedures established there.

## Energy Control

3-1 As an electrical maintenance worker, you should know that servicing an energized piece of equipment is an open invitation to an accident. You should also know, however, that throwing the main switch is not all that is required for safe maintenance. *Energy control* involves not only shutting off electricity but also releasing any stored mechanical, pneumatic, or hydraulic energy that might be present in the equipment. Your goal should be to bring the equipment to a *zero energy state*. This concept will be discussed in detail later in this chapter.

**WARNING: Never attempt to make repairs on electrical equipment unless you have the proper training, including training in lockout procedures.**

3-2 The Department should have a written plan with instructions for de-energizing each system or piece of equipment. The plan should include the voltage level and short-circuit capabilities of the equipment to be de-energized. This information will define the level of hazard. The plan should include specific instructions for switching, as well as information on the required protective equipment.

3-3 Finally, the plan should include instructions for re-energizing. Re-energizing is often considered to be more dangerous than de-energizing. Before re-energizing, you must:

- Notify personnel to stay clear
- Inspect the area to make certain that all tools and supplies have been removed
- Secure enclosure doors
- Remove locks and tags

## Electrical Safety Lockout

3-4 If the unexpected start-up of equipment is likely to endanger you or other people, you cannot simply de-energize the equipment. The switch you turn off might be turned on again by someone else. Power to the equipment must be locked out at the main disconnect before work begins. A padlock and a multiple-lock hasp, with instructions for their use, should be available to every electrical worker in the plant. Sometimes you might need more than one lock to lock out every power source supplying the electrical equipment to be serviced.

3-5 Most switch boxes are made so that a padlock can be snapped into place. Before you work on a machine, lock out the main power source and leave the padlock in place until you finish the job, or until you are relieved by another worker who will replace your lock with his or her own.

3-6 Even when the power is locked out, wear protective equipment and use insulated tools. To prevent accidents, treat dead circuits as though they are live. Test any circuit before starting work to make sure it is de-energized. This precaution can prevent an accident.

## OSHA Lockout/Tagout Procedures

- 3-7 OSHA has established standards covering lockout and tagout (29 CFR 1910.147 and 1910.333). They are designed to help safeguard workers from hazardous energy while they are performing maintenance on machines or equipment. The standards state that equipment must be turned off and disconnected from the energy source prior to servicing. In addition, they require employers to develop written lockout/tagout procedures, to train all those employees who could be injured by accidental start-up or the release of stored energy, and to carry out periodic inspections (at least annually) to ensure that the energy control procedures are being implemented properly.
- 3-8 The OSHA standards include guidelines for bringing about a zero energy state, which makes it impossible for a machine to be activated accidentally while someone is working on it. You should never work on a machine until you have brought it to this state.
- 3-9 **Lockout/tagout** is bringing machinery to a zero energy state that begins with locking out the power. Each worker should have an assigned lock, a key, and a lockout device. No two keys should fit the same lock. Your initials or your clock number should be stamped on your lock. The procedure for locking out the power to a piece of equipment consists of the following steps:
- Notify the operator that you will be working on the machine.
  - Turn off the electric power and attach the lockout device to the energy-isolating device (that is, the circuit breaker or disconnect switch) in such a way that the power cannot be turned on.
  - Place your own padlock on the lockout device. Anyone else who is working on the same equipment should add his or her own lock to the lockout device.
  - Place an appropriate warning sign (tag) at the controls indicating that work is in progress. An example is shown in Figure 3.1.



Figure 3.1: Tags Indicate Work in Progress

## OSHA Lockout/Tagout Procedures (continued)

3-10 In order to bring a machine to a zero energy state, you must take the following steps after you have locked out the power and before you begin work:

- Push the START button to make sure that the power is disconnected. Then push the STOP button (to prevent accidental start-up once power is turned on again).
- Make sure that all moving parts of the equipment have come to a complete stop.
- Check for pneumatic and hydraulic lines in the machinery. (They should be marked with labels or signs.) If they affect the area in which you are going to work, bleed, drain, or purge them to eliminate the pressure. Vent air valves to the atmosphere and drain surge tanks and reservoirs to prevent pressure buildup in the lines. The valves controlling these lines should then be locked out. A lockout device on a valve is shown in Figure 3.2.
- Now check for mechanisms that are under spring tension or compression or are suspended. Block, clamp, or chain them in position.
- Check for sharp or projecting parts or surfaces that can cut or gouge you. Either remove them or pad them, whichever is easier.
- Make a voltage measurement at the point of exposure.



Figure 3.2: Valve Lockout Device



## OSHA Lockout/Tagout Procedures (continued)

- 3-11 When you have completed your work, inspect the work area to make sure that all tools and other items have been cleaned up and that all safety guards are in place. Other workers should stand a safe distance from equipment or circuits being re-energized. Do not turn on electricity, compressed air, or water, and never start any machinery without first checking to make sure no one is in a position to be injured.
- 3-12 When the inspection is complete, remove your own lock. The last worker to remove his or her lock also may remove the lockout device. Never remove anyone else's lock or tag, and never allow anyone to remove yours. If you lose your key, notify your supervisor at once and get a new lock and key. Finally, test the machinery for proper operation and notify the operator that the machine is back in operating condition.
- 3-13 **Tagout**, in most cases, is when warning tags are used along with locks. In some cases, however, lockout might not be possible. Equipment must then be tagged out. Lockout is the preferred method, since no one can remove your lock without your key. Tags are not as safe as locks, because they can easily be removed, overlooked, or ignored. In tagout applications, it becomes even more important for all employees to receive the proper training. Everyone must be aware of correct tagout procedures to ensure safe working conditions.
- 3-14 Essentially, a tag or tagout device is a warning device that takes the place of a lock without providing the physical restraint of a lock. A tag simply identifies a source of potential danger and indicates that the equipment being worked on may not be operated until the tag is removed. Tags should never be bypassed or ignored.
- 3-15 For an electrical tagout, OSHA requires that you disconnect the circuit in another location. Methods include pulling a fuse or opening a disconnect.
- 3-16 Keep in mind that lockout/tagout procedures are not for the purpose of slowing you down or making your job more difficult. They are for your safety. But you must do more than follow the rules. For example, if you do not have enough lockout devices available, ask for them. Even if you feel that a project will take only a few minutes to complete, use the lockout system.
- 3-17 Never put up with someone else's failure to follow the energy control procedures established by the Department. If the procedures are being bypassed or if part of the procedure is lacking, report the situation to your supervisor or someone else who can correct the problem. Remember that you can be injured by someone else's failure to follow safe working procedures.
- 3-18 Your only sure protection is to bring each machine you work on to a zero energy state. Workers who have not learned this lesson are the ones who suffer the most serious injuries. Take no chances. Take no shortcuts. Do not depend on someone else to protect you. Take those few extra moments to do the job right and protect yourself.

## Using Power Tools Safely

- 3-19 One of your most frequent encounters with electrical equipment will probably be with portable power tools. The main electrical danger when using power tools is the short circuit. Metal parts of any tool, machine, or structure can become current conductors if damage occurs to electrical wiring or insulation.
- 3-20 When a short circuit occurs, the handle or case of the tool becomes part of the circuit. Remember, electricity takes any available path to the ground. If the tool has not been grounded properly, one path to the ground is through the body of the worker holding the tool. The result might be only a mild shock. However, it might be a serious burn or a fatal jolt of electricity.
- 3-21 When using power tools, your body is protected by the grounding wire, which provides a low resistance path from metal to ground and carries away most of the current. However, this path never carries all the current. If your body is not insulated from the ground and comes in contact with the circuit, you will receive a shock. When correctly designed and connected, the low-resistance path should make the shock harmless. In places where high ground conductivity creates a lower-than-normal resistance through the worker, a ground fault circuit interrupter (GFCI) should be used. These devices are covered in detail in the following lesson.
- 3-22 Stationary electrical equipment can be grounded permanently by connecting all metal parts through a heavy conductor to a metal water pipe or other metal structure buried in the ground. Both the connection and the structure should be checked frequently to ensure that their resistance remains low. If plastic fittings and pipes are used to carry water, another ground must be selected in order to provide an uninterrupted metallic path to ground. Otherwise, the equipment will not be grounded. Equipment grounding will be covered in more detail in Chapter Four.
- 3-23 Electrically powered portable tools and other portable equipment require a more involved procedure to ground them and make them safe. Most portable power tools have three wires in the line cord and come equipped with three-prong plugs, as shown in Figure 3.3. The third wire is a grounding wire connected to the metal housing of the tool. If there is a short circuit to the housing of the tool, this wire carries the current to ground. The fuse blows, but the worker feels little or nothing. You can see how this arrangement works by comparing Fig. 3-4A and Fig. 3-4B, on the following page. When using these tools, it is necessary only to provide three-slot receptacles that are reliably grounded.

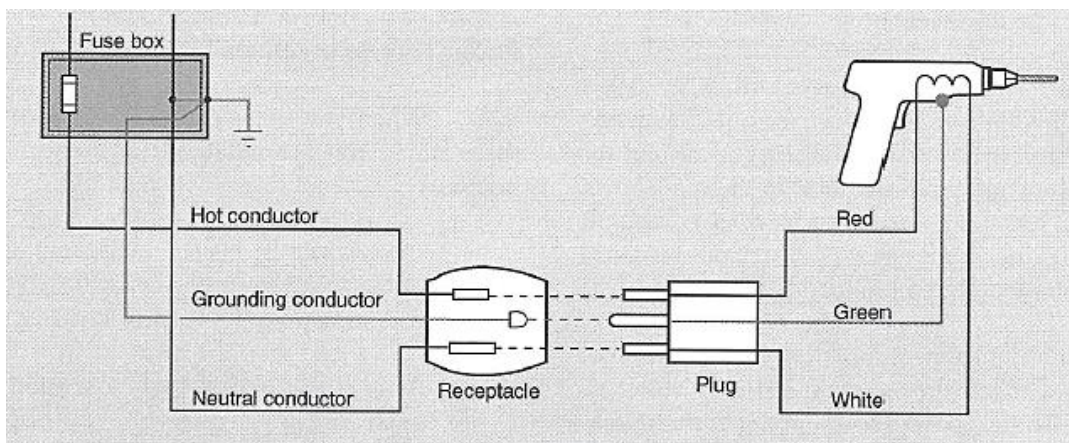

**Figure 3.3: Three-wire plug and Receptacle**

## Using Power Tools Safely (continued)

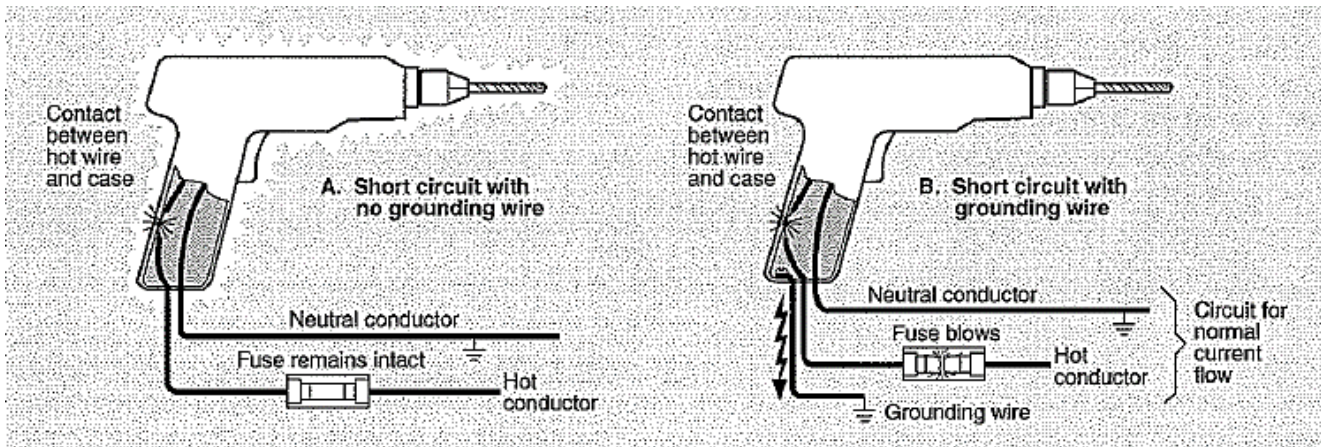

**Figure 3.4: Grounding wire Carries Current to Ground**

- 3-24 Unfortunately, the three-prong grounding system has two drawbacks. The most serious one is that the system is easily bypassed. If a grounded receptacle is not available, do not be tempted to use a two-prong adapter. This adapter—commonly called a "suicide plug" is not considered a reliable method of grounding. Another way to bypass the system is to break off the grounding pin on the plug, thereby breaking the grounding path. Even if you use a three-prong plug, there is no guarantee that the receptacle is connected to a reliable ground.
- 3-25 The second drawback occurs if the tool is properly grounded and you touch an ungrounded, faulted electrical device such as a live wire with faulty insulation. In this case, fault current passes through your body.
- 3-26 Most power tools made today are equipped with three-conductor cords and polarized grounding plugs. Some tools, however, are double-insulated and do not require grounding. These two-wire tools are sometimes used in place of three-wire grounded equipment. They are the only two-wire tools that can be used safely. Use these tools whenever possible. They should be plainly labeled to indicate that they are double-insulated.
- 3-27 The ordinary insulation of wires is called *functional insulation*. All electric tools have this insulation, as it is necessary to direct the current for the proper functioning of the tool. In the tool shown in Figure 3.5, functional insulation is used around all current-carrying components—brushes, armature windings, stator coils, commutator, and wiring.

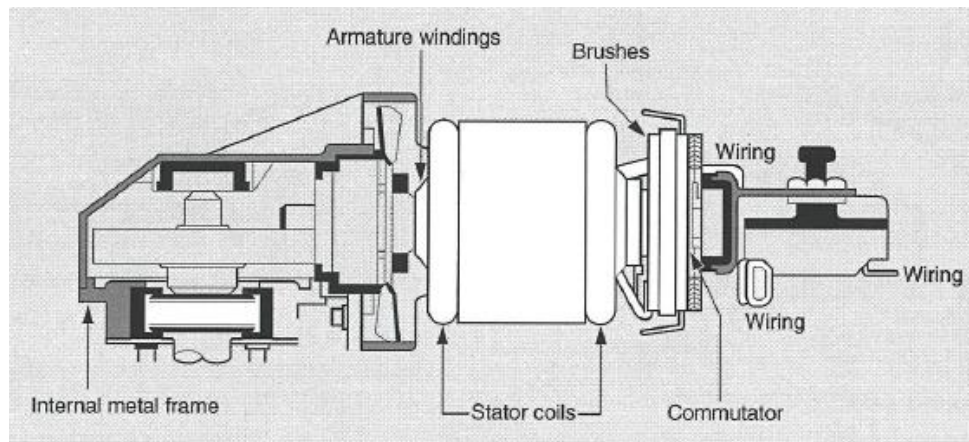

**Figure 3.5: Power Tool with Functional Insulation**

## Using Power Tools Safely (continued)

3-28 Double-insulated tools have an additional, independent insulation system called *protective insulation*. The extra insulation protects the operator against electric shock if the functional insulation fails. The double-insulated tool in Figure 3.6, has an armature construction similar to that of a conventional tool. The motor assembly is mounted in a metal skeleton frame that is housed in a plastic, non-conducting case. The housing of the switch is also plastic. If a metal case is used, it has a plastic liner that isolates any metal parts that might become energized if the functional insulation fails. In addition, the tool shaft or arbor is fitted with an insulating sleeve. Double-insulated tools must be kept clean and dry. If you use them, handle them carefully so the insulation is not damaged and always inspect them before use.

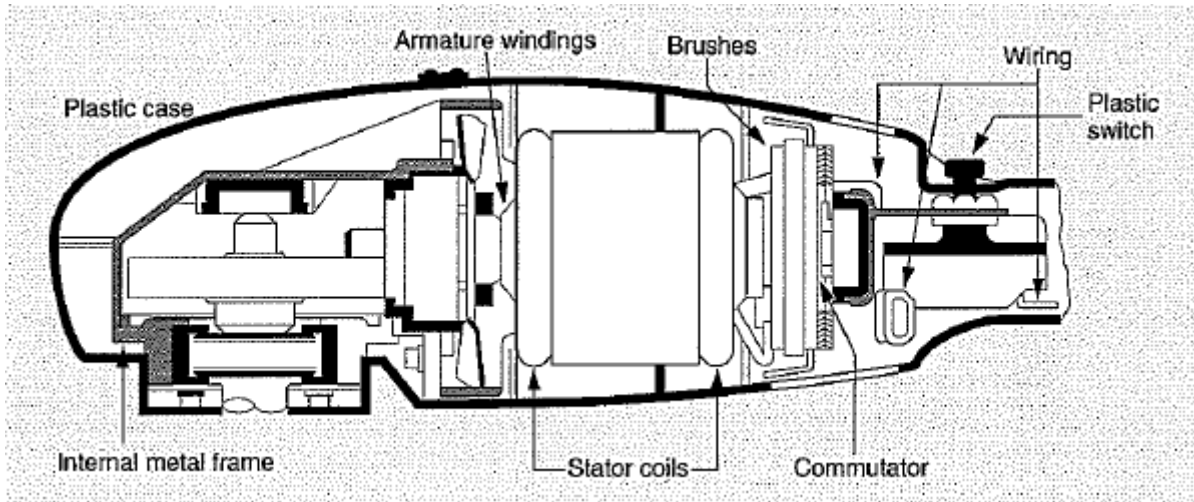

Figure 3.6: Power Tool with Functional Insulation

3-29 Misuse of a tool by an operator is a major cause of insulation breakdown. Another cause is the entry of metal chips or other foreign particles and contaminants into the tool. These particles often enter through the tool's cooling system.

## Power Tool Safety Rules

3-30 When you use electric power tools, follow these safety rules to reduce your chances of being injured.

- Understand the intended uses and limitations of the tool before beginning to work with it. Know the potential hazards involved.
- Always use a GFCI when working with a three-wire grounded tool.
- Inspect all power tools before use, including all guards, the case, the line cord, and accessories. Never, under any circumstances, use a damaged or faulty power tool. Never use a tool with a frayed or cracked power cord. When electric-powered tools are in need of (C) repair, apply a lockout device and danger tag on the plug end to guard against accidental use. Turn in the tool for repair, or repair it yourself if you are authorized to do so. Maintaining power tools keeps them efficient as well as safe.
- Do not cut or drill into any surface until you have made sure that there are no electric wires that you might cut into or scrape. If you cut into a concealed wire, a short circuit might result. Make sure that any electrical power lines you are working on or near are turned off. Many accidents result from cutting into power lines. Route electrical cords so that they will not be cut or tripped over.
- Do not operate an electric tool on a wet surface, and do not set it down on one. A wet surface increases the possibility and the severity of an electric shock.
- Make particularly sure that all the circuits are in safe operating condition before you use the tool. Remember that the tool will work even if the equipment grounding wire is disconnected, broken or bypassed. That third wire is the one that protects you from shock and burns.
- Whenever you change bits, blades, or other accessories, make sure that you have first turned off the power and pulled the plug. Turn off tools when you finish a job or temporarily stop working. The next user of a tool might start it accidentally when reconnecting it if it is left on. As an added precaution, make sure the switch is off before plugging in a tool. Never leave a running tool unattended.
- Many electric tools have a safety feature called a "deadman" trigger or switch. This switch automatically cuts off the power when the pressure of the operator's hand or finger is removed. Never try to bypass this feature by wiring or taping the switch in position.

## Recognizing Electric Shock Victims

3-31 Sometimes, despite all your precautions, an accident might occur. If that accident involves electric shock, some specialized procedures might be required to save the victim's life.

3-32 Often it is not easy to recognize the symptoms of electric shock. A victim might or might not have any external symptoms. However, some clues are:

- Loss of consciousness
- Irregular or weak pulse
- Burns at the entry and exit points of the current

3-33 All shock victims or suspected victims should receive prompt medical attention, even if they appear to be uninjured or claim to feel fine. Some internal injuries will not be obvious to the untrained observer. These injuries

can, however, cause extreme pain. Sometimes breathing and circulatory problems can develop hours after contact. For this reason, any shock victim should be observed by a medical professional.

## First Aid for Shock Victims

3-34 The most important things to know about first aid for shock victims are:

- Never touch a shock victim who is still in contact with the electrical source.
- Act quickly because seconds count! Your actions could make the difference between life and death.
- Do not offer first aid unless you are qualified. You could make things worse. If you are untrained, send for medical assistance.

3-35 If you touch someone who is in contact with the electrical source, you too will become part of the circuit. Then there will be two victims instead of one. Although it is important to act quickly, it is even more important to think before you act!

3-36 A victim who contacts a live conductor might be thrown free as a result of muscle spasms. If, however, the person is "frozen" to the energized conductor, the first thing to do is to shut off the electricity. If the shutoff is very far away, drag or push the victim away from the electricity with a piece of nonconductive material. Make sure that the material you use is dry. Using moist or damp material to disconnect the victim from an energized circuit is a much greater hazard. If live wires are lying on or near the victim, use a nonconductive material to move them away.

3-37 Start first aid as soon as it is safe to do so. Move the victim only if he/she is in an unsafe location. Unnecessary movement could make a spinal injury worse if one is present. Treat burns with cool compresses. If the victim is conscious, call for professional assistance. Then question the victim about what happened. This information could be important to medical professionals. Stay with the victim until help arrives.

3-38 If the victim is unconscious, check for breathing and a heartbeat. If these vital signs are absent, you must act within approximately 4 minutes or the victim is likely to suffer permanent brain damage. After 6 minutes without a pulse or respiration, brain damage or death almost always occurs.

3-39 All workers, especially those who work with electricity, should be trained in *cardiopulmonary resuscitation* (CPR). CPR is an emergency procedure used to restore respiration (breathing) and circulation (blood flow) after these functions have stopped. It makes it possible to revive a person from what would otherwise have been a fatal electric shock. Once a person's heartbeat and breathing have stopped, that person is considered clinically dead. Permanent damage from a lack of oxygen occurs first in the brain, then in other organs of the body. The sooner CPR begins, the less chance there is for brain damage.

3-40 Prompt and proper application of CPR can also save the life of someone who would otherwise die as a result of heart attack, drowning, suffocation, choking, or automobile accident. If you are not trained in CPR or need a refresher course, check with the Department's safety section, your local fire or police department, the American Red Cross, or the American Heart Association. A brief CPR summary follows to illustrate how relatively simple this

procedure is. It can also serve as a reminder for those already trained in CPR. Never attempt to perform CPR unless you have been trained.

### **First Aid for Shock Victims (continued)**

- 3-41 The first step in CPR is to check the scene and the person. Ensure the scene is safe then tap the person on the shoulder and shout "Are you OK?" to ensure that the person needs help. Call 911 (or ask a bystander to call) for assistance if it is evident that the person needs help then send someone to get an Automated External Defibrillator (AED). If an AED is unavailable, or no bystander to access it, stay with the victim and begin administering assistance.
- 3-42 Your body uses only about 20% of the oxygen that you inhale with each breath. The 80% remaining in the air that you exhale is sufficient to sustain life when blown into the lungs of a shock, heart attack, or accident victim.
- 3-43 The next step in CPR is to check the victim for a heartbeat. Usually the easiest way to tell if the victim has a pulse is to check the carotid artery in the neck. Feel gently for a pulse without compressing the area. Take several seconds to check for a pulse. If there is even a weak pulse, you must not begin chest compressions.
- 3-44 If the heart has stopped, external chest compression allows oxygen-carrying blood to travel to the brain and other vital organs. It is never performed without rescue breathing. External chest compression is the process of rhythmically applying and releasing pressure over the lower half of the breastbone. When performing chest compressions, you must apply enough force to compress the area around the heart.
- 3-45 CPR is most easily performed by two people working together, although it can be performed by only one. If you come upon a situation in which CPR is required and you are not trained in CPR, you can help by calling for someone who has that training, and then telephoning for professional medical help.



## The ABCs of CPR

**Warning:** You must be trained by an expert before you administer CPR. Also, you must never practice these procedures on a real person. Chest compression can result in cracked ribs and punctured lungs. Specially made dummies are available for this purpose. Do not use these techniques on infants, as different procedures are required.

### Step A: AIRWAY opened

- With the person lying on his or her back, tilt the head back slightly to lift the chin. Check for breathing and watch to see if the victim's chest is rising and falling for no more than 10 seconds. (Occasional gasping sounds do not equate to breathing) If the victim is breathing, make certain that the airway remains open and the victim continues to breathe.

### Step B: BREATHING restored

- If the victim is not breathing, begin CPR immediately. Pinch the nose closed, take a deep breath, and make a seal between the victim's mouth and yours. Give two slow, gentle breaths into his or her mouth, as shown in Figure 3.7.



**Figure 3.7: Artificial Respiration**

- Watch for movement of the victim's chest.
- If there is no movement of the chest, check the victim's mouth for obstructions. Tilt the victim's head farther back and try again to give two breaths.
- If there is chest movement, check for a pulse. If the victim has a pulse, give one breath every 5 seconds until breathing resumes. If there is no pulse, begin Step C immediately.



## The ABCs of CPR (continued)

### Step C: CIRCULATION restored

- The proper hand position for chest compression is shown in Figure 3.8. Position your hands over the center of the chest with your dominant hand on the bottom.



**Figure 3.8: Proper Hand Position for Cardiac Compression**

- Depress this area of the chest at least 2 inches 30 times, at a rate of at least 100 compressions per minute, while positioned as shown in Figure 3.9. Compress and release smoothly. Your hands should remain in contact with the victim's chest.



**Figure 3.9: Proper Position of Rescuer and Victim**

## The ABCs of CPR (continued)

### Step C: CIRCULATION restored (continued)

- After 30 compressions, give two gentle breaths, as described in Step B. After four compression/breath cycles, recheck for a pulse.
- Continue cycles of compressions and breaths until the person exhibits signs of life such as breathing an AED becomes available, EMS or a trained medical responder arrives on scene, the scene becomes unsafe, or until you can no longer do so.

3-46 If the victim seems to be breathing regularly, lay him or her flat and raise the legs slightly by placing something under them. Keep the victim warm. Do not try to give the victim anything to drink if he or she is unconscious or nauseous. If the victim is burned, cut away loose clothing and immerse the burned area in cold water.

3-47 Get medical assistance as soon as possible for any victim of electric shock. First aid is essential, but professional medical attention might be necessary even if the victim appears to have recovered.

## Chapter 3 Exercise

Circle the appropriate letter next to the correct answer.

1. After you have brought a piece of equipment to a zero energy state, you can \_\_\_\_\_.
  - a. Remove the lockout device
  - b. Remove your PPE
  - c. Safely begin work on the equipment
  - d. Warn other workers to stay clear
  
2. Under what conditions should you remove another worker's lock from a lockout device?
  - a. After repairs are completed
  - b. If it interferes with machine operation
  - c. If you have that person's permission
  - d. None
  
3. Tags and tagout devices \_\_\_\_\_.
  - a. Are better than lockout devices for preventing accidental startup
  - b. Do not provide the physical restraint of lockout devices
  - c. May be removed after all moving parts have come to a stop
  - d. May be used instead of lockout devices if the shutdown is short
  
4. If your employer does not have enough lockout devices available, you should \_\_\_\_\_.
  - a. Ask the employer to buy more
  - b. Borrow one from a fellow worker
  - c. Do your work without one
  - d. Improvise by using something other than a lock
  
5. What is the main electrical danger when using power tools?
  - a. Excess heat
  - b. Low-resistance grounding
  - c. Overcurrent
  - d. Short circuit

### Chapter 3 Exercise (continued)

Circle the appropriate letter next to the correct answer.

6. Equipment can be permanently grounded by connecting it to a \_\_\_\_\_ structure, \_\_\_\_\_ Ground.
- a. Metal; above
  - b. Metal; below
  - c. Plastic; above
  - d. Plastic; below
7. In double-insulated tools, protection against electric shock is provided by the \_\_\_\_\_.
- a. Plastic case or liner
  - b. Shaft or arbor
  - c. Three-wire supply cord
  - d. Two-prong adapter
8. If an electric tool has a deadman switch, the switch \_\_\_\_\_.
- a. Cuts off power when pressure is released
  - b. Has short-circuited
  - c. Is in need of repair
  - d. Should be taped in the ON position
9. If a person who has received an electric shock is frozen to the conductor, the first thing to do is \_\_\_\_\_.
- a. Begin CPR
  - b. Pull the person away from the conductor
  - c. Send for medical assistance
  - d. Shut off the electricity
10. If a shock victim is without a pulse or respiration, how much time does a rescuer have to restore these vital functions if the victim is to avoid permanent damage?
- a. 30 seconds
  - b. 4 minutes
  - c. 10 minutes
  - d. 30 minutes

## Summary

The Department should have a written plan for de-energizing and re-energizing each piece of equipment. Before beginning maintenance, you must not only switch off electrical power, but also release any stored mechanical, pneumatic, or hydraulic energy that might be present. You must bring the equipment to a zero energy state. In addition, you must never attempt to make any electrical repairs unless you have the proper training.

OSHA has an established lockout/tagout standard that details the procedures in this very important part of electrical maintenance. Lockout involves shutting off power, applying a lock to the switch, and testing the system to ensure that it will not start. Tagout is sometimes used if power is cannot be locked out, although lockout is preferred. Tags must be able to withstand environmental conditions and must attach securely to the energy-isolating device.

Short circuits present on of the main hazards when working with portable power tools. It is very important that these tools be properly grounded and that their insulation be in good condition. Ordinary power tools have functional insulation. Double-insulated tools have protective insulation, which offers an additional system of insulation around all current-carrying components. Handle tools carefully to avoid damaging the insulation and always use them properly.

Some common systems of electric shock are loss of consciousness, weak pulse, breathing difficulty, and burns. If you encounter an electric shock victim, quick action could save his or her life. Take care, however, not to jeopardize you own life. If they are still in contact with the electrical source, shut off the power or free them carefully with a nonconductive material. If you are properly trained, begin first aid and CPR as needed. Finally, call for medical attention.



# Chapter 4: Grounding, Ground Faults, and Short Circuits

## In This Chapter:

Equipment Grounding

Visual Indication of Ground for Ungrounded Circuits

Circuit Grounding

Grounded Conductor Alarms

Protection Against Ground Faults

Detecting Faults Automatically

Transformer Grounding

Static Electricity

Grounding Through Enclosures

## Objectives

After completing this manual, you should be able to:

- State the reason why circuits should be grounded.
- Explain how to test a circuit for proper grounding.
- Explain how a ground-fault circuit interrupter works.
- Contrast current electricity and static electricity and explain why each can be hazardous.
- Identify the correct extinguisher to use on flammable liquid fires and on energized electrical equipment fires.

## Terminology

**Ground:** Any connection between an electric circuit and the earth

**Ground fault:** An unplanned connection to ground or an unintentional ground

**Grounding structure:** A metal frame or other structure not connected to the earth

**Ground-fault circuit interrupter (GFCI):** A device that interrupts a circuit when it detects a ground fault

**Static electricity:** Unlike current electricity, it involves electrons that accumulate on an object

Each year in the United States, approximately 1000 to 1200 people are killed by electricity (excluding lightning). This number is quite small, considering the number of people living in this country and the amount of electrical equipment used in homes, on farms, in industrial plants, and on streets and highways. The number of deaths is low because so much attention is given to electrical safety, including grounding. If you are careless about grounding, you could add to the number of deaths, either with your own or with someone else's.

When electrical equipment and circuits are not properly grounded, a potentially dangerous situation exists. Grounding is one of the most effective ways of preventing electrical accidents. OSHA inspectors report finding hundreds of times as many electrical hazards as any other type of hazard. More than two-thirds of the violations involve faulty grounding. It is the goal of this lesson, therefore, to provide you with a thorough understanding of electrical grounding, ground faults, and proper grounding techniques.

## Equipment Grounding

- 4-1 A *ground* is any connection between an electric circuit and the earth. Proper grounding helps equipment users avoid contact with hot circuits and also helps limit voltages when one circuit shorts to an adjacent circuit. Unplanned connections to ground are called *ground faults* or *unintentional grounds*. Ground faults generally occur when equipment insulation has been damaged. They also can occur when equipment is abused such as when an electric power tool is accidentally placed in water.
- 4-2 Electrical equipment is grounded with a separate, green or green-and-yellow striped wire. The grounding wire carries current only when a ground fault occurs between the hot conductor and the housing of the equipment or tool. If the fault current is large enough, it will blow the fuse or trip the circuit breaker. If not, most of the fault current will flow through the grounding wire. Keep in mind, however, that some current can still pass through your body. Ungrounded two-wire equipment provides no protection. If the housing becomes energized, the electricity can only flow to ground through your body.
- 4-3 If two-slot receptacles are in service, they should be replaced with properly wired three-slot receptacles before using any piece of equipment that has a three-prong plug. Notice in Figure 4.1 that the shape and arrangement of the prongs and the slots make it impossible to connect the grounding wire incorrectly. This arrangement does not mean that protective measures will always work well, however.

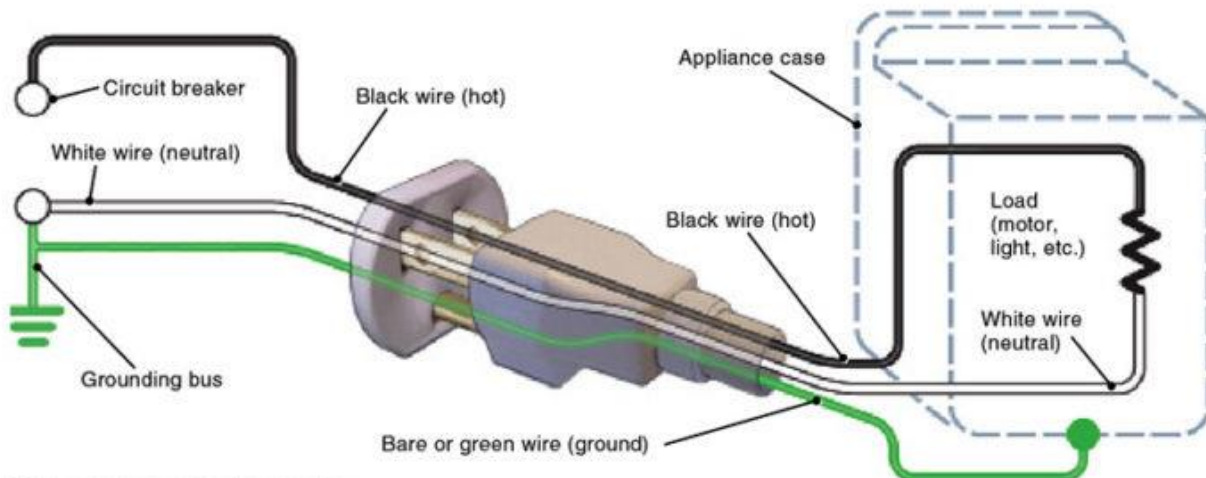

Figure 4.1: Three-Wire Plug and Receptacle



## Equipment Grounding (continued)

- 4-4 If the grounding wire is not connected properly or securely or if the grounding system is in poor condition, it will not be effective. This situation can cause even more of the current to flow through your body if a fault develops. For this reason, the grounding wire and its connection should be checked regularly. A receptacle tester can be used to check very quickly for correct receptacle wiring and grounding. A combination of indicating lights on the plug-in device can reveal a specific problem or indicate a properly wired system. An example is shown in Figure 4.2.

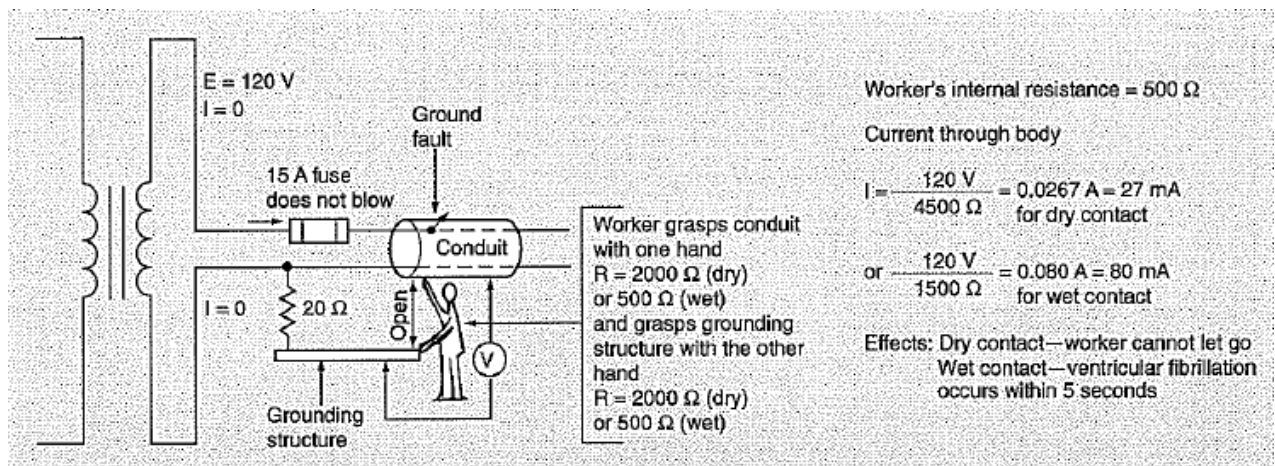

Figure 4.2: Receptacle Tester

**WARNING:** Under no circumstances should the grounding prong be bent or broken off to make a three-prong plug fit into a two-slot receptacle. This unsafe act endangers you and other workers.

## Circuit Grounding

- 4-5 Circuits are grounded to avoid unnecessary and dangerous potential differences between two conducting surfaces. Circuit grounding also limits potential differences that might occur by contact between the circuit and other equipment that are values higher than the circuit are designed to withstand.
- 4-6 To illustrate the need for proper grounding, look at the low-voltage circuit in the diagrams on this page and the following pages. These circuits are typical of those you can expect to find in almost any industrial plant.
- 4-7 Figure 4.3 is a diagram of a distribution transformer with 120 V service leads. A grounding connection at the service has a resistance of  $20\ \Omega$  between the neutral conductor and a *grounding structure*. This grounding structure is not the earth. It might be a metal frame or other structure that is not connected to the earth.



**Figure 4.3: Ungrounded Conduit**

- 4.8 One conductor from the transformer is equipped with a 15 amp fuse. The metal conduit is not connected to the grounding structure, however, so in the diagram the connection between the conduit and the ground is labeled "open."
- 4-9 Suppose the insulation fails at one point on the 120 V conductor, allowing it to make contact with the conduit. The potential difference between the conduit and the ground is then 120 V. Because the conduit is ungrounded, there is no fault current. The conduit can remain energized at 120 V indefinitely. Anyone making contact between the conduit and ground would experience a shock. You can calculate how serious this shock would be by using Ohm's law.
- 4-10 In order to calculate how serious the shock would be, you must make certain assumptions. For example, suppose you assume that someone grabs the conduit with one hand while holding onto a grounded structure with the other. Table 4-1 shows the approximate resistance at each contact, and the internal resistance of the worker's body. Figure 4-3 shows the following. The resistance also depends on how tightly the person grips the metal, and on other factors.
- If the contact is dry, the resistance at each hand is about  $2000\ \Omega$ , making a total resistance of about  $4500\ \Omega$  ( $2000 + 2000 + 500$ ).

- If the contact is wet, the resistance at each hand may be only 500 Q, making a total resistance of about 1500 Q (500 + 500 + 500).

## Circuit Grounding (continued)

Connection	Resistance	
	Dry	Wet
Finger touch	40 to 1000 kΩ	4 to 15 kΩ
Hand holding wire	15 to 50 k	3 to 6 k
Finger-thumb grasp	10 to 30 k	2 to 5 k
Hand holding pliers	5 to 10 k	1 to 3 k
Palm touch	3 to 8 k	1 to 2 k
Hand around pipe	1 to 3 k	500 to 1500 k
Two hands around pipe	500 to 1500 k	250 to 500 k
Hand in water	—	200 to 300 k
Foot in water	—	100 to 300 k
Internal, excluding skin	—	200 to 1000 k

4.11 The resistance of the connection between the neutral conductor and the ground (20 Q) must be added to the resistance of the body. However, the effect of this resistance is small compared to the resistance of the body, and you can neglect it in this case. The potential difference across the person's body is almost the full 120 V between the two conductors.

4.12 You can use Ohm's law to calculate the current through the worker's body. This calculation is shown in Figure 4.3. The current is about 27 mA if the contact is dry, and about 80 mA if the contact is wet. From Table 4-2 you can see that even if the contact is dry, the current is high enough to prevent the worker from releasing his or her grip and breaking the circuit.

Current	Effects	Feeling or Result
0 to 1 mA	None	Imperceptible
1 to 3 mA		Mild sensation
3 to 10 mA		Painful
10 mA	Arms paralyzed	Cannot release hand grip
30 mA	Breathing muscles paralyzed	Unable to breathe (may be fatal)
75 mA	Causes fibrillation in some People within 5 seconds	Heart action becomes uncoordinated (probably fatal)
250 mA	Cause fibrillation in almost everyone 5 seconds	

4A	Heart Paralysis	Hear stops during shock, but may restart when shock Ends (usually not fatal due to heart un-coordination)
More than 5 A	Tissues burned	Not fatal unless vital organs are burned

### Circuit Grounding (continued)

4-13 From Table 4-3 you can see that if the contact is wet (resistance = 1500 Ω), the worker's heart will go into ventricular fibrillation within about 5 seconds. The worker will die unless he is released from the electrical path and his heart is restarted within 4 minutes.

Potential Difference	Shock Duration
120 v AC.....	4.2 Seconds
240.....	1.05 Seconds
277.....	0.8 Seconds
480.....	0.26 Seconds

For 150 pound human with a resistance of 1500 Ω

4-14 An improvement in the grounding is shown in Figure 4.4. The conduit is connected to the ground by a path having a resistance of 10 Ω. How much protection does this path offer?

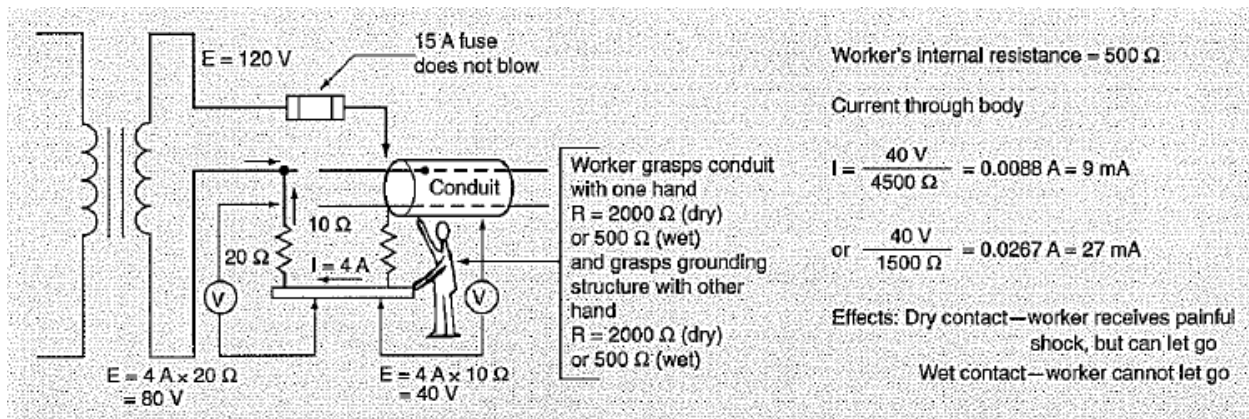

Figure 4.4: Conduit Grounded Through Resistive Path

4-15 If the insulation fails and the 120 V conductor makes contact with the external conduit, a potential difference of 120 V exists across the path from the conduit to the opposite side of the transformer. This path has a total resistance of 30 Ω. Therefore, the current in the path is 4 A as shown by the calculation included in Figure 4.4. As in the first example, this current is not High enough to blow the 15 A fuse.

4-16 The potential difference of 120 V between the two sides of the transformer is now divided into two parts.

- 40 V between the conduit and the grounding structure
- 80 V between the grounding structure and the opposite side of the secondary of the transformer.

4-17 Now suppose the same worker grabs both the conduit and the grounding structure. Under dry conditions, the worker's body creates a path having a resistance of 4500  $\Omega$  in parallel with the 10  $\Omega$  path. What is the effect on the worker's body?

### Circuit Grounding (continued)

4-18 The potential difference across the worker's body is limited to 40 V, because of the parallel 10  $\Omega$  path from the conduit to the grounding structure. Therefore, the current through the worker's body is only about 9 mA, as shown by the calculations in Figure 4-4. You can see from Table 4-2 that this current will cause a painful shock, but the worker will be able to let go of the metal structures and break the circuit. Even if the contact is wet, the current will be only about 27 mA (40 V divided by 1500  $\Omega$ ). This current will prevent the worker from releasing his grip, and breathing may be impossible.

4-19 Finally, suppose the connection from the conduit to the grounding structure is a short length of heavy copper wire, having no resistance, as shown in Figure 4.5. In addition, suppose the connection from the grounding structure to the opposite side of the transformer has a resistance of only 2  $\Omega$ . What is the effect of an insulation failure in this example?

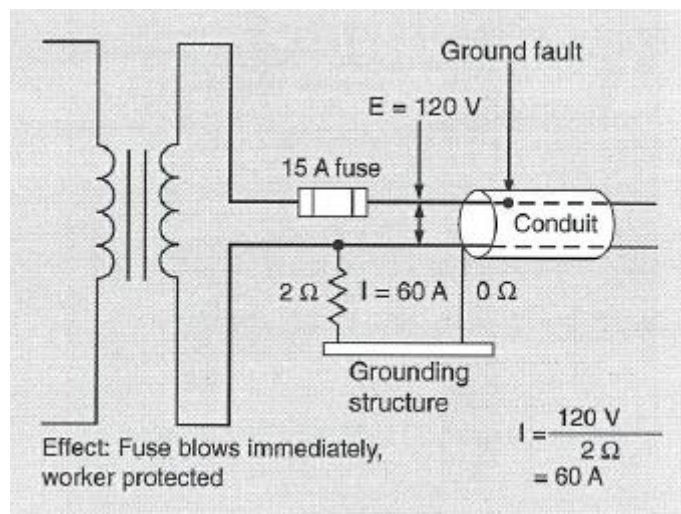

**Figure 4.5: Conduit Grounded Through 0  $\Omega$  Path**

4-20 If the insulation fails, the potential difference of 120 V is applied across a resistance of only 2  $\Omega$ . The current is therefore 60 A, as shown by the calculation in Figure 4.5. This current quickly blows the 15 A fuse, and disconnects the transformer from the conduit. Anyone who grabs the conduit and the grounding structure under these circumstances will be protected from an electric shock.

4-21 You can see from these examples that proper grounding is very important for the safety of anyone who works or lives around electrical equipment. Proper grounding and overcurrent protection are necessary to disconnect a

circuit from the power source quickly if a fault occurs. If grounding is inadequate or nonexistent, a circuit can become lethal if a fault develops.

- 4-22 The National Electrical Code (NEC) specifies the minimum provisions necessary for "the practical safeguarding of persons and property from hazards arising from the use of electricity." The NEC is a valuable reference tool that contains a great deal of information on the subject of grounding. Whenever you refer to the NEC, make sure you have the latest edition. The latest edition is the 2017 version.

## Protection Against Ground Faults

- 4-23 Depending on conditions and on the nature of the contact, a ground fault has either high or low resistance. When the resistance is low, large amounts of current can flow, blowing the fuse or tripping the circuit breaker. When this happens, the fault current exists only for the very short time that it takes the fuse or circuit breaker to cut off the current in the circuit.
- 4-24 When the fault circuit has a high resistance, a *ground-fault circuit interrupter* (GFCI) provides the necessary protection. Under normal conditions as shown in Figure 4.6, the current in the two conductors is equal and the GFCI does nothing. However, the instant a ground fault occurs, as shown at the right in the figure, the current in the two wires becomes unequal. The GFCI compares the current in the two conductors of a circuit. If the current differs even slightly, as happens when a ground fault allows part of the current to bypass a section of one conductor, the GFCI opens the circuit stopping the flow of all the current in the circuit.

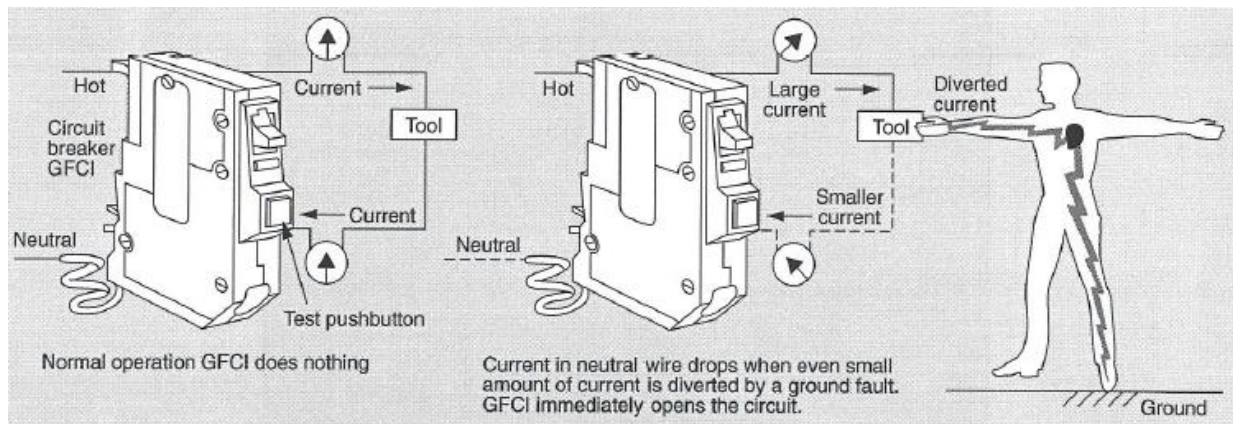

**Figure 4.6: Ground-Fault Circuit Interrupter**

- 4-25 Because the GFCI operates in a split second, it is the *only* method of reliably protecting personnel from injury. Built-in GFCIs have been required in many circuits since about 1970 even if these circuits are also protected by fuses or circuit breakers. Fuses and circuit breakers simply do not respond quickly enough to protect human life. GFCIs generally respond to hot-to-neutral wire faults and line-to-line faults as well as ground faults. They add to the protection offered by fuses and circuit breakers because they can be tripped by a very small amount of current (as little as 5 mA) acting for only a fraction of a second.

## Protection Against Ground Faults (continued)

4-26 Some GFCIs are small enough to be carried in a toolbox and plugged in at the point of use. A portable GFCI is shown in Figure 4.7. Others are installed in the power distribution center. Either type satisfies the NEC. Because of the protection they provide, GFCIs are being installed in many 120 V circuits especially those used for portable electric tools. Receptacles installed outdoors or in bathrooms must be equipped with GFCIs. Most GFCI instructions include a simple test procedure involving a pushbutton. To ensure satisfactory operation, it is essential that the manufacturer's test be performed regularly.



Figure 4.7: Portable Ground-Fault Circuit Interrupter



## Transformer Grounding

4-27 All the proceeding examples involve a branch-circuit ground fault. What happens when a fault develops between the primary and secondary sides of a transformer as shown in Figure 4.8. This diagram shows a substation that supplies 2400 V to the building transformers. The transformer in the substation is grounded on its secondary side.

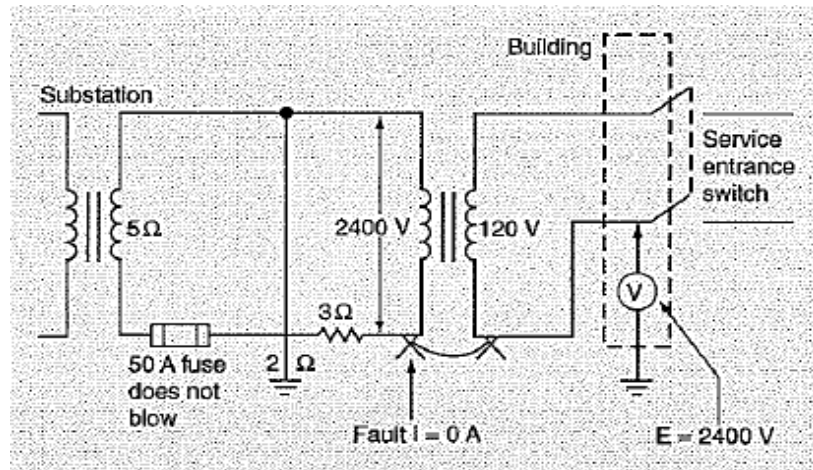

Figure 4.7: Portable Ground-Fault Circuit Interrupter

4-28 Suppose a fault occurs between the primary and secondary sides of the building transformer. Because there is no secondary ground on the building transformer there is no fault current. Instead, the secondary system rises to the potential difference of the primary 2400 V system.

4-29 Figure 4.9 shows the same circuit with two 10 Ω grounds added. A secondary ground on the transformer and a ground on the line side of the service entrance switch. The two 10 Ω grounds in parallel have a combined resistance of 5 Ω. To this resistance you must add the resistance of the substation line and the impedance of the substation transformer.

Two building grounds	5 Ω
Substation line	3 Ω
Substation transformer	5 Ω
<u>Ground connection</u>	<u>2 Ω</u>
Total	15 Ω

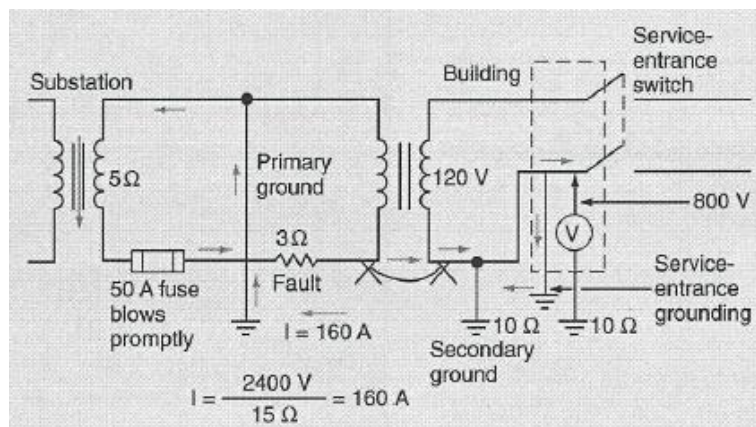

Figure 4.9: Fault in Properly Grounded Transformer

## Transformer Grounding (continued)

- 4-30 The fault in the building transformer applies a potential difference of 2400 V across this total resistance of 15  $\Omega$ . The current is therefore 160 A, as shown by the calculation in Figure 4.9. The 160 A current far exceeds the rating of the 50 A fuse located in the substation line, and therefore the fuse quickly blows.
- 4-31 During the short period of time between the occurrence of the fault and the blowing of the fuse, a potential difference exists between the secondary of the building transformer and the ground. According to Ohm's law, this potential difference is 800 V, not the full 2400 V produced by the transformer. The value is based on a current of 160 A combined with a resistance of 5  $\Omega$ .

## Effects of Impedance

- 4-32 In the examples given so far, the fault has been assumed to have no impedance. The following examples are based on the same circuit shown in Figure 4.9 except that the fault adds an impedance of 30 or 60  $\Omega$ .
- If the fault has an impedance of 30  $\Omega$ , the total impedance becomes 45  $\Omega$ —15  $\Omega$  in the distribution circuit and the substation transformer, plus 30  $\Omega$  in the fault. In this case, the current in the fault circuit is 53.33 A (2400 V divided by 45  $\Omega$ ). This current is still high enough to blow the fuse. The potential difference between the building line and ground is 267 V (53.33 A x 5  $\Omega$ ) until the fuse blows.
  - If the fault has an impedance of 60  $\Omega$ , the total impedance is 75  $\Omega$ . Then the fault current is only 32 A (2400 V divided by 75  $\Omega$ ), an amount too small to blow the 50 A fuse. A potential difference of 160 V (32 A x 5  $\Omega$ ) will remain indefinitely between the building line and ground.
- 4-33 These examples show the value of low impedance in an equipment ground. The lower the impedance, the lower the potential difference that can exist from the equipment to ground if a fault occurs.
- 4-34 Ungrounded low-voltage systems permit primary voltage to appear on the low-voltage wiring under fault conditions. They create a hazard in the normally non-energized metal parts in an electrical system.
- 4-35 There are two kinds of low-voltage system connections; Y and delta. Each is grounded differently. Both are shown in Figure 4.10. Each way has its own advantages and disadvantages.
- One of the main advantages of the grounded Y is that the lower potential difference between each phase and the neutral decreases the likelihood of insulation failure. This is particularly true in 480 and 577 V circuits, which operate near the 600 V rating of the insulation on the wire.
  - The main disadvantage of the grounded Y is that the protective devices in the system must be equipped with an overcurrent element in each phase to recognize all ground faults.

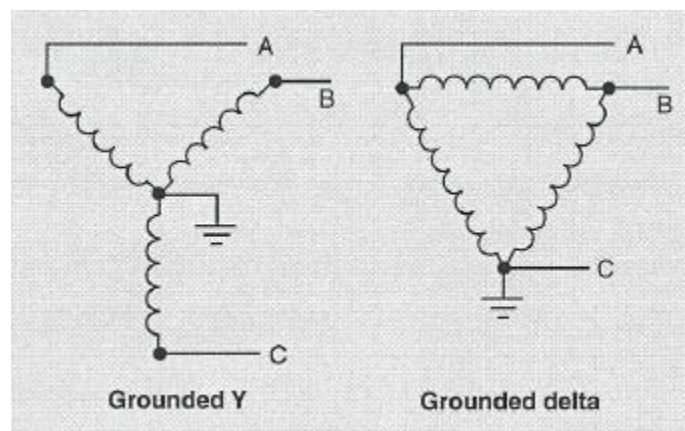
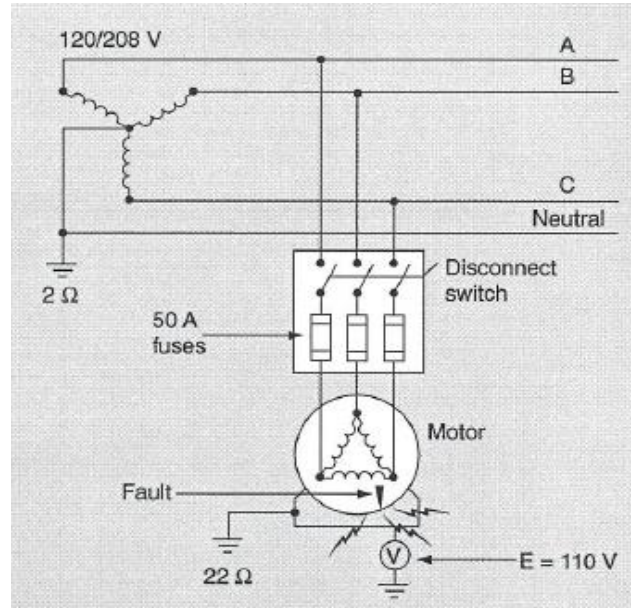

Figure 4.10: Grounding Low-Voltage Systems

- 4-36 The most important feature necessary for adequate equipment grounding is a low-impedance path for the return of the fault current to the source of power. If a low-impedance path is not available, the current may not be high enough to operate the overcurrent devices in the circuit.

### Effects of Impedance (continued)

- 4-37 Figure 4.11 shows a grounded Y secondary system with a neutral solidly grounded through a  $2\ \Omega$  ground. The secondary potential difference is 120/208 V. The load on the branch circuit is protected by 50 A fuses, and the load is grounded separately through a  $22\ \Omega$  ground connection. There is no ground connection between the transformer and the load.



**Figure 4.11: Motor not Grounded to Transformer**

- 4-38 When the fault occurs in the motor, the  $2\ \Omega$  ground is connected in series with the  $22\ \Omega$  ground, making a total resistance of  $24\ \Omega$ . The potential difference across this resistance is 120 V, producing a current of 5 A. This current is not sufficient to blow the fuses protecting the motor. Instead, the current maintains a potential difference of 110 V between the motor casing and ground.

## Effects of Impedance (continued)

- 4-39 The same circuit is shown in Figure 4.12, but with an equipment ground between the transformer and the motor. Suppose this line has a resistance of  $1 \Omega$ . If the same fault occurs in the motor, it will cause a current of 120 A. This current blows the 50 A fuse and clears the fault from the system. In general, equipment-ground impedance should be low enough to pass a current of at least twice the rating of the overcurrent device at the phase-to-ground potential difference.

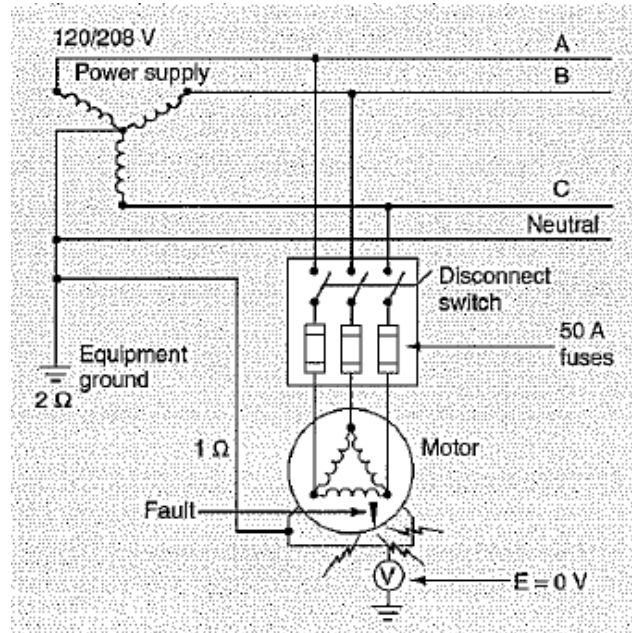

Figure 4.12: Motor Grounded to Transformer

- 4-40 What apparatus is used in a typical plant to furnish the low-impedance path? Figure 4.13 shows a grounded, Y-connected transformer secondary. The grounding wire is the first link between the transformer and the equipment ground for the plant. The other links shown in the diagram are the equipment grounding lines.

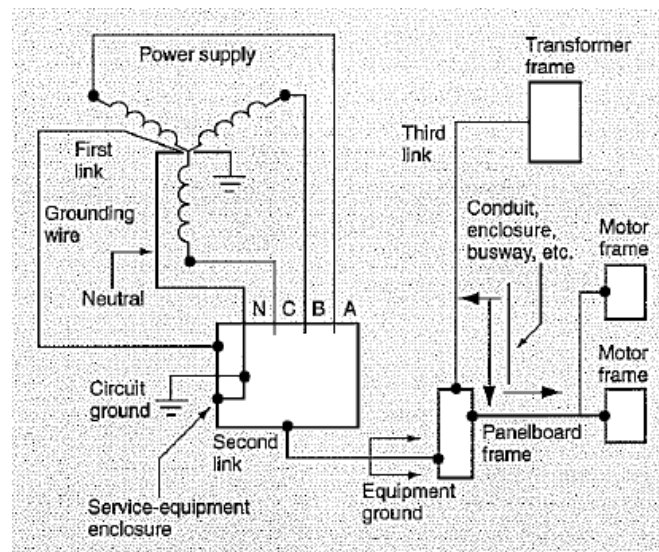

Figure 4.13: Links in a Grounding System

## Grounding Through Enclosures

- 4-41 From the service equipment, the equipment ground is continued by way of conduit or bus-duct enclosure to a panelboard frame. From the panelboard frame, the equipment ground is continued to all the panelboard circuits by means of metallic conduit, bus-duct enclosures, or wire raceways.
- 4-42 The method of grounding through enclosures is the most commonly used system for equipment grounding today. Tests have shown that either conduit or a busway, installed without a parallel grounding circuit, is an effective equipment ground. Generally, you can assume that any enclosure approved by Underwriters Laboratories Inc. has a low-enough impedance to handle short-circuit fault currents.
- 4-43 In most cases, equipment that is approved and installed properly is capable of providing a low-impedance grounding path if it has no loose joints. However, periodic inspections may reveal joints in an enclosure that have increased in impedance as a result of vibration, corrosion from nearby chemical processes, or lack of expansion joints. In these cases, you may need to bond the joints. You can bond the joints with a copper wire or other corrosion-resistant material that serves as the bonding jumper
- 4-44 You should inspect a busway both during installation and periodically thereafter. The purpose of these inspections is to make sure a low impedance path is maintained throughout the duct enclosure. The inspection should involve testing the resistance of the duct enclosure joints to see that the bolted connections have not developed high resistance because of corrosive materials in the plant. One such test is the visual indication described in the following paragraphs.



## Visual Indication of Ground for Ungrounded Circuits

4-45 A circuit that provides a visual indication of a grounded phase conductor is shown at the left in Figure 4.14. It consists of three potential transformers connected Y-Y, with neutrals grounded. Although the potential transformers are connected line-to-neutral, they must have a rating equal to the line-to-line potential difference. Either voltmeters or indicating lights may be used as detectors. Either voltmeters or indicating lights may be used as detectors.

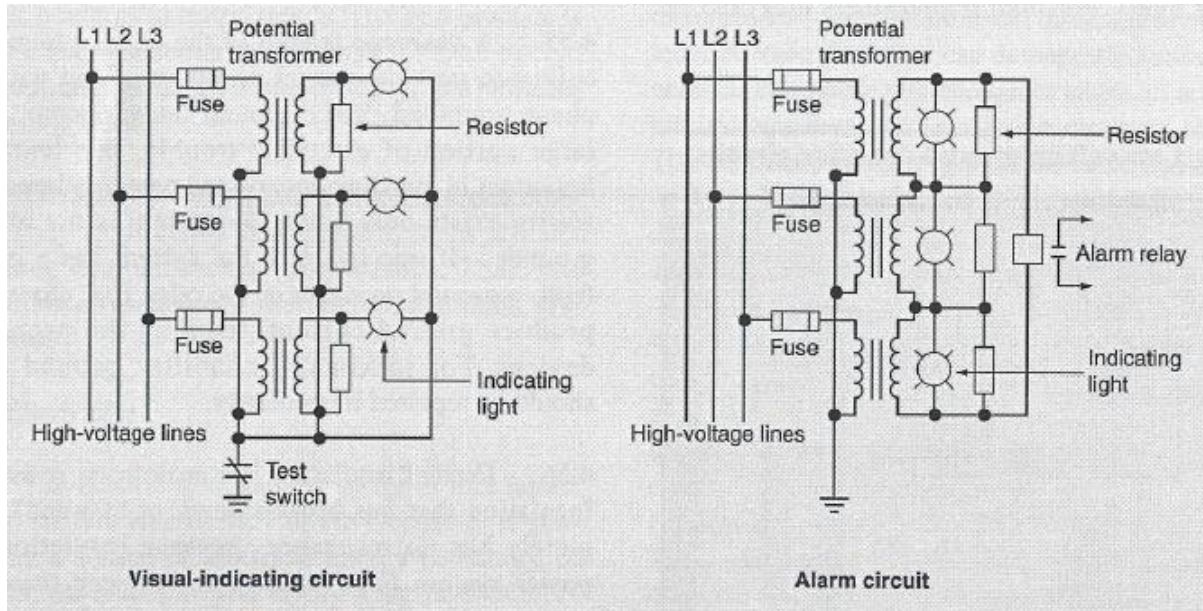
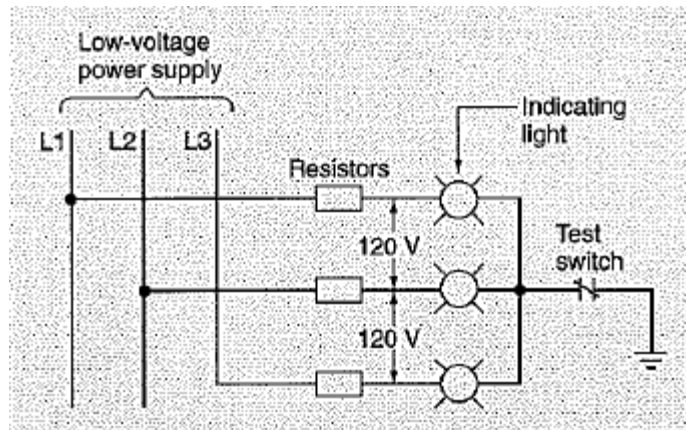

Figure 4.14: Ground-Indicating Circuits

4-46 Under normal conditions, all three indicating lights will glow dimly. Unintentional grounding of one phase will cause the full line-to-line potential difference to appear across the other two potential transformers. Then the indicating light corresponding to the grounded phase will go out, and the lights to the other two phases will glow at their full 120 V brightness.

## Grounded Conductor Alarms

- 4-47 A commonly used circuit that sounds an alarm to indicate a grounded phase conductor is shown by the diagram at the right in Figure 4.14. This circuit not only provides a visual indication of a grounded conductor (by means of the indicating lights), but also operates a relay that sounds an alarm.
- 4-48 Each of the three potential transformer primaries is connected from phase to ground. Under normal conditions, the potential difference from the primary to ground equals the line-to-line potential difference divided by the square root of 3. For the circuit shown in Figure 4.15, this value is 120 V divided by the square root of 3, which is about 69 V.



**Figure 4.15: Low-Voltage Ground-Detection Circuits**

- 4-49 If one phase becomes grounded, the full line-to-line potential difference appears across the primaries of two potential transformers. The potential difference across the secondary of each potential transformer is 120 V. The potential difference across the open delta, or across the overvoltage relay, is 208 V. This potential difference causes the relay contacts to close and operate the alarm circuit.
- 4-50 A low-voltage system (under 600 V) uses the same principle of ground detection. A common, inexpensive method is to use resistors in series with the indicating lights, arranged as in Figure 4.15. The resistors serve only to reduce the potential difference between the lines to the 120 V rating of the indicating lights. Potential transformers may also be used.
- 4-51 The main advantage of ground-detection schemes on an ungrounded system is that any ground on the line can be detected and removed rapidly. The alternative is to shut down the system as soon as the ground occurs. In some plants, shutdowns are very serious—either because certain processes must not be stopped, or because the loss of production is very expensive.
- 4-52 Immediate tripping is especially beneficial. The fault is quickly cleared with a minimum of damage to equipment and system. The ground cannot progress to a more severe line-to-line or multiple fault.



## Detecting Ground Faults Automatically

- 4-53 Three-phase, four-wire Y systems with grounded neutrals offer unmatched safety and protection. A phase-to-ground fault is quickly detected, and the solid portion of electrical trouble, this feature is important in avoiding unexpected power failures. This ability exists only when the system is not already grounded. If one phase of the system has a ground fault, a ground on either of the other two phases will produce ground current, tripping the protective devices. For maximum reliability, ground faults should be repaired immediately.
- 4-56 Perfect insulation has an infinite resistance. Insulation that has broken down or "faulted" completely has no resistance. Average insulation in a power system falls somewhere between these two extremes. Usual values are in the range of one million to ten million ohms (1 to 10 megohms). A fault exists if the insulation has a low-enough resistance to permit a significant current.
- 4-57 Insulation seldom breaks down suddenly at operating potential differences. It deteriorates gradually over a period of time. Therefore, it is important to know that the insulation resistance is declining long before the insulation actually fails. With this knowledge, you can schedule repairs in an orderly and economical way.
- 4-58 In the past, the standard method of monitoring for ground faults was to sense the phase-to-ground potential difference with lamps, meters, or other voltage-sensitive devices. These devices have a number of limitations and are used mainly to indicate a complete breakdown of insulation. These devices do not become sensitive until the insulation resistance has dropped to around 10,000  $\Omega$ . Therefore, they give no early warning of insulation deterioration.
- 4-59 For an accurate check on an electrical system, the common practice is to measure the insulation resistance with DC test equipment. To make these measurements, the power must be shut off and circuits isolated from one another. This procedure is costly, so these measurements are generally made only once a year.
- 4-60 Readings obtained are of limited value unless they are recorded. They must also be standardized to account for variable conditions, and then compared to previous readings to reveal trends. The best practice is to keep a graph showing the readings for each circuit. An abrupt change in the slope of the graph indicates approaching trouble.
- 4-61 Because of inadequate methods of detecting faults, many ungrounded three-phase systems actually limp along with undetected ground faults. Thus, one of the main advantages of the ungrounded delta system is lost.

## Static Electricity

- 4-62 The electricity discussed so far in this lesson is called *current electricity*. Current electricity is generated by a source of electrical energy (a battery or generator, for example) and involves the flow of electrons. Virtually all of the electricity that you use is current electricity. Another kind of electricity, *static electricity*, must be covered here briefly because it is present in almost all industrial operations and manufacturing processes. Static electricity involves charges that remain unmoving on an object.
- 4-63 Everyone has come into contact with static electricity at one time or another. You have seen signs of its presence when you run a comb through your hair on a dry day. Your hair seems to stand on end and "reach" for the comb. Your hair is actually losing electrons to the comb. Your hair becomes positively charged as a result of this loss of electrons. The comb becomes negatively charged when it gains electrons.
- 4-64 You can place a charge on yourself by shuffling your feet across a carpeted room on a dry day. This charge will give you a mild shock when you touch a doorknob or other metal object. The electrons that you collected are "jumping" to an object with fewer electrons.
- 4-65 In most situations, static electricity is more a nuisance than a hazard. Although it is easily generated, static electricity itself is not dangerous either because the charge is weak or because it leaks off as quickly as it is formed. Except for lightening (which is nothing more than a giant static discharge formed in the layers of the earth's atmosphere) no one has ever been killed by a static electricity shock.
- 4-66 In many situations, it is impossible NOT to generate static electricity. Generation, however, is not the problem—accumulation and discharge are the problems. A static discharge can damage electronic components. It can startle you enough to cause an accident or fall. In some cases, you can see its discharge as a spark. These sparks can easily ignite flammable liquids, vapor, or dusts. Many injuries and millions of dollars of damage occur in industry each year as a result of fires and explosions caused by static electricity.
- 4-67 As mentioned earlier, static electricity can be generated by friction between two surfaces. It also can be generated by the separation of two unlike materials. A common situation in which static electricity presents a serious hazard is the transfer of flammable liquids from one container to another. The rapid separation that occurs as liquid exits the original container can cause static electricity to be generated.
- 4-68 Several methods are available for preventing the accumulation of static electricity. Grounding is the most common. Grounding prevents the accumulation of static electricity by channeling it to the ground. Many approved static electricity grounding devices are available. To be effective, a grounding device must be a good conductor of electricity and it must make a path to the earth.

## Static Electricity (continued)

4-69 Figure 4.16 shows containers properly grounded for the transfer of a flammable liquid. The containers must be connected with a ground wire, and at least one of the containers must be connected to a permanent ground. To be effective, complete metal-to-metal contact must be made throughout the grounding system so that any accumulated static reaches the ground. Remove any rust, paint, or other coating that could prevent good contact between the grounding wire and the container.

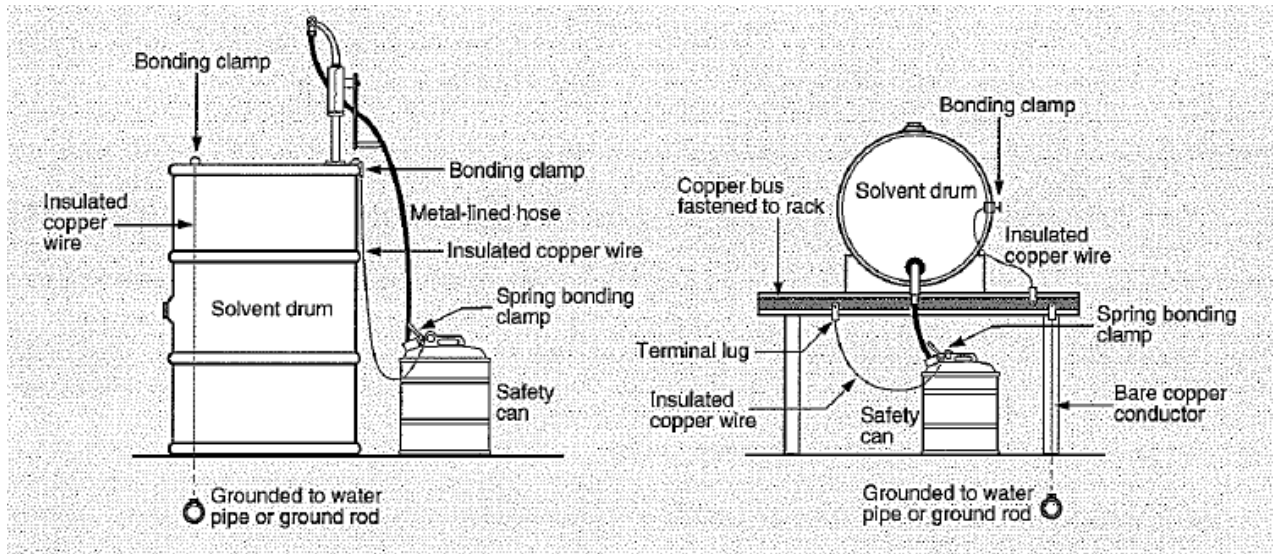

**Figure 4.16: Proper Grounding for Transfer of Flammable Liquids**

4-70 It is essential that you ground equipment before you begin the job. Grounding after you have begun the job can cause sparks. In an explosive atmosphere, this action could be disastrous.

4-71 If a fire should occur, it is important that you know how to extinguish it. Water extinguishes many fires by cooling the fuel below the temperature at which it burns. However, water does not extinguish all fires. In fact, water can spread fires involving gasoline, oil, and other chemicals that float on water. Different kinds of fires must be put out in different ways. Table 4-4 lists the four classes of fire extinguishers as well as the types of fires that they are designed to extinguish. The most important thing to remember is this: never attempt to fight a fire that could endanger you. Instead, leave the area immediately and sound the alarm.

<b>Class of Fire Extinguisher</b>	<b>Type of Fire</b>
<b>A</b>	Fires in ordinary combustible materials
<b>B</b>	Fires in flammable liquids
<b>C</b>	Fires in energized electrical equipment
<b>D</b>	Fires in combustible materials that can explode such as Lithium (Li), Sodium (Na) And Potassium ((K)

## Chapter 4 Exercise

Circle the appropriate letter next to the correct answer.

1. What is the potential difference between an ungrounded conduit and ground if the conduit makes contact with a 12 V line?
  - a. 0 V
  - b. 60 V
  - c. 90 V
  - d. 120 V
  
2. Which of the following compares the current in two conductors in a circuit and opens the circuit if they differ?
  - a. Autotransformer
  - b. DC test equipment
  - c. Fault meter
  - d. GFCI
  
3. If two 10  $\Omega$  grounds are connected in parallel, the combined resistance to ground is \_\_\_\_\_  $\Omega$ .
  - a. 5
  - b. 10
  - c. 15
  - d. 20
  
4. What is the most important feature for adequate equipment grounding?
  - a. Insulation
  - b. Low current
  - c. Low-impedance
  - d. Overcurrent devices
  
5. The two kinds of low-voltage system connections are \_\_\_\_\_ and \_\_\_\_\_.
  - a. Faulted; un-faulted
  - b. Intentional; unintentional
  - c. Primary; secondary
  - d. Y; delta

## Chapter 4 Exercise (continued)

Circle the appropriate letter next to the correct answer.

6. The main advantage of a ground-detection scheme on an underground system is \_\_\_\_\_.
- a. It is slow to trip
  - b. It removes any grounds rapidly
  - c. Its cost is low
  - d. The system needs no monitoring
7. In applications where service continuity is not important, the preferred ground-fault detection system is the three-phase \_\_\_\_\_.
- a. Four-wire Y
  - b. Grounded delta
  - c. Ungrounded delta
  - d. Y-delta
8. Static electricity becomes dangerous when it \_\_\_\_\_.
- a. Involves a large amount of current
  - b. Is allowed to accumulate
  - c. Is grounded
  - d. Leaks off
9. You can prevent the accumulation of static electricity by \_\_\_\_\_ its source.
- a. Grounding
  - b. Heating
  - c. Insulating
  - d. Metering
10. What kind of extinguisher should be used to put out a fire involving energized electrical equipment?
- a. Class A
  - b. Class B
  - c. Class C
  - d. Class D

## Summary

All electrical equipment with which people may come in contact should be properly grounded to limit the possibility of shock and to avoid equipment damage. A low-impedance path in an equipment ground lowers the potential difference that can exist from the equipment to ground if a fault occurs. This can be accomplished by either ygrounding or delta-grounding.

The equipment ground is continued from the service equipment by means of an enclosure to the panelboard frame. Metallic conduit, bus-duct enclosures, or wire raceways make an effective equipment ground.

Additional protection is offered by the ground fault circuit interrupter. This device compares the current in the two conductors of a circuit and, if the currents differ even slightly, opens the circuit before the current can cause injury.

Ground-fault detection systems, which include alarms, flashing lights, and automatic tripping devices, are used for monitoring circuits. A fault meter constantly monitors the insulation resistance of a system and activates an alarm if the resistance falls below a certain level. The fault meter does not shut down the power system or disconnect the circuits.

# Chapter 5: Fuses and Circuit Breakers

## In This Chapter:

The purpose of a Fuse

Lead-Wire Fuses

Cartridge Fuses

Dual-Element Cartridge Fuses

Current-Limiting Fuses

Power Fuses

Cartridge Fuse Classes, Sizes, and Ratings

Installing Cartridge Fuses

Plug Fuses

Glass-Tube Fuses

Kinds of Circuit Breakers

Magnetic Circuit Breakers

Thermal-Magnetic Circuit Breakers

Ambient-Compensated Circuit Breakers

Molded-Case Circuit Breakers

Low-Voltage Power Circuit Breakers

Circuit Breaker Tripping

Circuit Breaker Reset and Fuse Replacement

## Objectives

After completing this manual, you should be able to:

- Explain how a dual-element cartridge fuse works.
- State the NEC rules on installing fuses.
- Explain how a circuit breaker works.
- Describe molded-case circuit breakers.
- List the steps involved in fuse replacement and/or circuit breaker reset.

## Terminology

**Overcurrent protective device:** A device that protects the circuit, surrounding materials, and people from excess current

**Expulsion fuse:** A fuse that expels hot gases when it blows

**Non-expulsion device:** A fuse protected against arcing and gas expulsion

**Circuit breaker:** A device that can automatically interrupt the current in a circuit

**Interrupting capacity:** Fault current a circuit breaker can interrupt without damage to itself

All electrical systems require some kind of protection against overloads and short circuits. This protection usually takes the form of a fuse or circuit breaker. Fuses and circuit breakers are designed to act as "safety valves" for electric circuits by keeping circuits from becoming overloaded. They protect you by cutting off the electricity to equipment with damaged or defective circuits that could produce shocks or start fires. They also protect the equipment from excess current.

Fuses and circuit breakers are made in many different styles and sizes for various voltages and loads. Electrical maintenance workers must have a thorough understanding of these devices and their operating characteristics in order to choose intelligently.

This lesson explains the types and classifications of both cartridge and plug fuses and their applications. It also explains various kinds of circuit breakers and their operating characteristics and applications. Equipment and personnel safety are important considerations in selecting and installing protective devices. Keep your own safety in mind when working with electrical equipment and always follow safety rules.

## The Purpose of a Fuse

- 5-1 If a circuit carries too much current, the fuse opens and breaks the circuit. For example, the fuse opens if there is a short circuit. When the fuse opens, the current becomes zero. With zero current, equipment on the line cannot operate. The fuse also opens if there is an overload condition in the equipment or in the line. An overload is a condition in a circuit that causes the current to be too high. The open fuse protects the equipment from being damaged by the overload.
- 5-2 A fuse is one kind of *overcurrent protective device*. Another common example of such a device is the circuit breaker, which is covered later in this lesson. All overcurrent protective devices protect the circuit, the surrounding materials, and people from being harmed by excess current in the circuit.
- 5-3 A fuse must do four things in a circuit. It must:
- Sense the amount of current in the circuit
  - Open quickly when the current becomes excessive
  - Fail to open during a normal temporary overload
  - Function without affecting the normal operation of the circuit
- 5-4 Older fuses were simply pieces of lead wire connected in the circuit. Current in the lead wire raised the temperature of the wire. The higher the current, the higher the temperature. Lead melts at a lower temperature than most metals, so the wire would melt if the current through it became too high.
- 5-5 The lead wire was kept short and fastened under screws. By selecting wire of the proper diameter, the fuse could be made to open the circuit at any desired current. When a lead fuse blew, molten metal splattered over equipment and people nearby. Lead-wire fuses were also a fire hazard if nothing confined the electric arc that formed as the fuse blew.

## Cartridge Fuses

- 5-6 The cartridge fuse has replaced the old lead-wire fuse. Figure 5.1 shows two kinds of cartridge-fuse construction in use today. Both kinds consist of a hard fiber cylinder surrounding a soft metal fuse strip. This strip is gripped by caps or ferrules on the ends of the fuse chamber. The entire cartridge is mounted in a fuse block. Figure 5.2 shows a fuse block. The cartridge fuse is held in the block by spring clips that grip the ferrules or the knife blades at the ends of the cartridge. The clips simplify the job of replacing a blown fuse.



Figure 5.1: Cartridge Fuses



Figure 5.2: Fuse Block for a Cartridge Fuse



## Cartridge Fuses (continued)

- 5-7 There are two basic kinds of cartridge fuses— renewable link and one time. Renewable-link fuses have removable end caps so that you can take out the damaged fuse link and replace it after the fuse blows. An example is shown in Figure 5.3. Renewable-link cartridge fuses have the same general characteristics as one-time fuses. They cost less to replace because the cartridges can be reused. Renewable-link fuses are no longer allowed in most new installations, although link replacement is permitted in existing installations.



Figure 5.3: Renewable-Link Cartridge Fuse

- 5-8 The one-time fuse is sealed by the manufacturer. One-time cartridge fuses offer protection against overloads where the fault current does not exceed 10,000 A. They are commonly used in lighting and heating circuits. The entire fuse must be replaced when it blows.
- 5-9 Figure 5.4 shows some of the fuse link configurations used in cartridge fuses. Areas A and B are calibrated to melt at a specific current, according to the rating of the fuse. Area C is made of zinc and has a thick cross section. This area absorbs heat to delay the blowing of the fuse and permit momentary overloads. In a circuit with a current in excess of 135% (a light overload), the link will open the areas marked B. In a short circuit or ground fault, the link will open in all areas marked A and B. The sections marked C will drop out in their original metallic form.

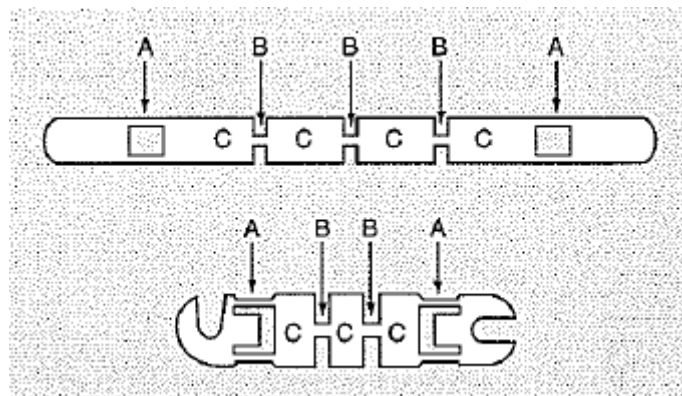
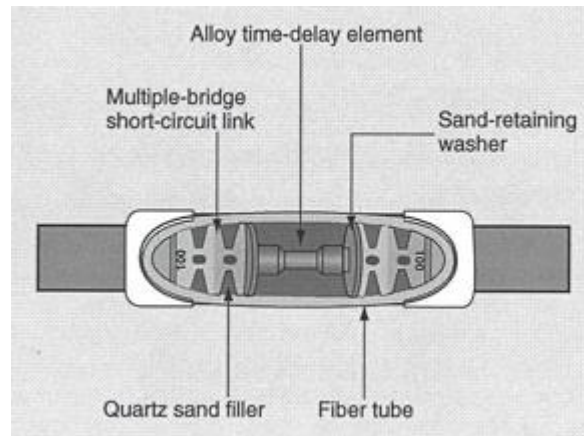

Figure 5.4: Fuse Links

**WARNING:** Always use nonconductive fuse tongs when removing or installing cartridge fuses.

## Dual-Element Cartridge Fuses

5-10 Dual-element cartridge fuses are designed mainly for motor circuit protection. The construction of this kind of cartridge fuse is shown in Figure 5.5. The fuse blows when either opens. For overloads, the opening of the fuse is achieved by the melting of a time-delay element made from an alloy. For short circuits, links on either end of the fuse blow in a fraction of an AC cycle.



**Figure 5.5: Dual-Element Cartridge Fuse**

5-11 The alloy used in the overload element melts at less than half the temperature increase required to melt the zinc links. Both excess current and a specific time period are required for this element to reach its melting point. If an overload persists, or if the magnitude of the overload increases, the alloy melts instantly without passing through a half-melted state. The alloy retains its shape and strength up to the point of becoming liquid. This action is shown in Figure 5.6.

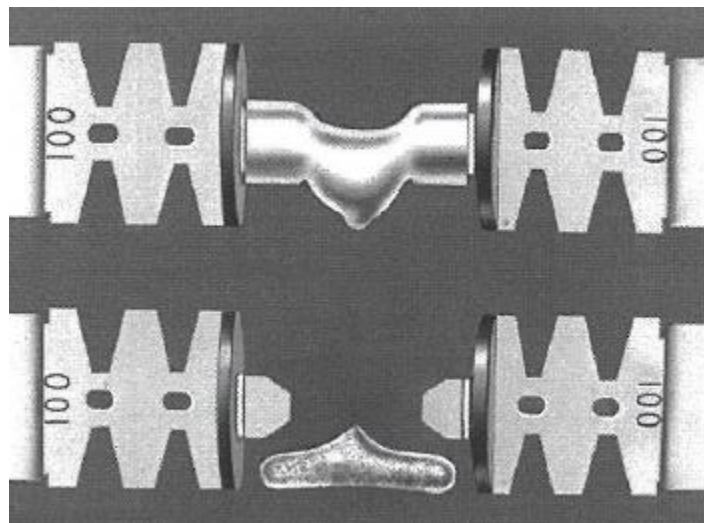

**Figure 5.6: Action of a Dual-Element Fuse**

5-12 When a short circuit occurs, the fuse links open the circuit immediately. The calibrated links have a series of melt bridges that blow when a fault occurs. Multiple bridges in the links cause the wider sections to drop out. These are replaced by quartz sand, which interrupts the arc quickly.



## Dual-Element Cartridge Fuses (continued)

5-13 Dual-element fuses have several advantages over single-element fuses:

- They can be selected to match the actual motor running current closely because they do not blow on harmless momentary overloads. Therefore, there is less nuisance blowing.
- Their low let-through current prevents the fault current from reaching destructive levels in the more vulnerable branch circuits and associated equipment. This would be less possible with ordinary single-element fuses or where more costly fuses are not justified.
- They can be more closely matched to the protective wiring and equipment because they are not subject to nuisance blowing. Therefore, the equipment used can be more compact and less expensive.
- They are ideally suited for protection of coils, relays, solenoids, and other magnetic equipment because the time-delay element will not blow on the momentary in-rush current. Yet, they will blow if the overload is sustained.

## Current-Limiting Fuses

5-14 Underwriters Laboratories describes a current-limiting fuse as one that starts to melt within 90 electrical degrees of a short circuit, and will open the circuit within 180 electrical degrees (half a cycle). Thus, a current-limiting fuse acts faster than an ordinary fuse. It limits the peak let-through current, therefore limiting the amount of energy allowed into the circuit.

5-15 High-capacity systems can produce extremely high fault currents. High fault currents can cause violent arcing and burning at the point of fault. They can bend copper bars in bus ducts and switchboards, melt and explode thermal overload units of combination starters, and weld contacts of motor controls. Current-limiting fuses interrupt the circuit very quickly, thus limiting energy let-through. Most fuses used in modern systems are current limiting.

## Power Fuses

5-16 Power fuses are designed for use in high-voltage installations. The potential differences range from 2300 to 30,000 V or more, depending on the power company. A typical power fuse is shown in Figure 5.7.

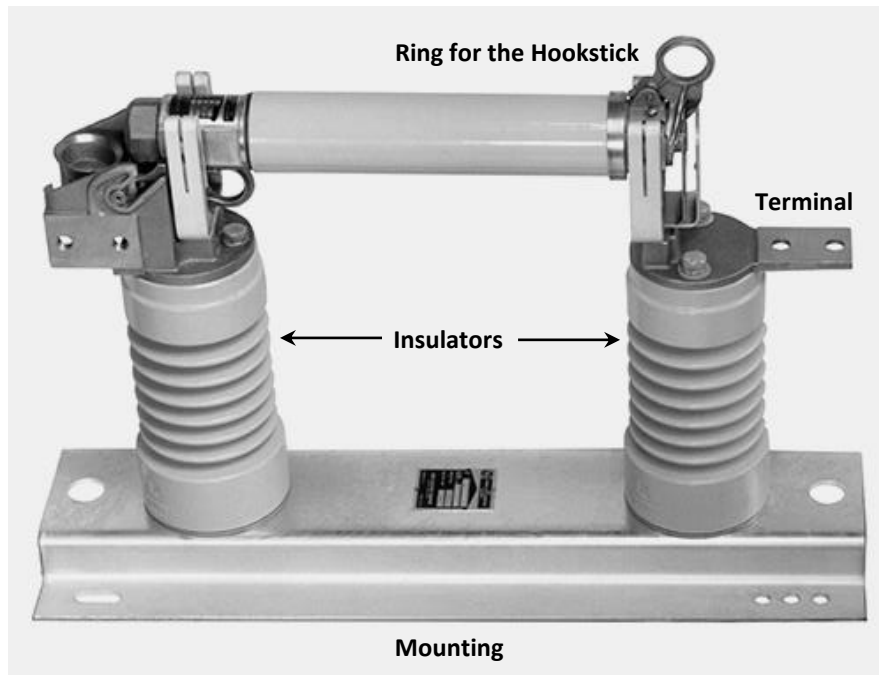

Figure 5.7: Power Fuse

5-17 Power fuses are used in load-interrupter circuits and are available in current-limiting or noncurrent-limiting types. Current-limiting fuses reduce the energy let-through. Two kinds of noncurrent-limiting power fuses are made. They operate in different ways.

- *Expulsion fuses* expel hot gases when they blow. This type of fuse should not be used indoors because of the hazard presented by the expelled gases. The NEC requires that expulsion fuses be designed to prevent any hazard to people or property.
- *Nonexpulsion fuses* have condensers or other protection against arcing and gas expulsion.

## Cartridge Fuse Classes, Sizes, and Ratings

- 5-18 Cartridge fuses come in a wide range of types, sizes, and ratings. Various classes are designated by NEMA (National Electrical Manufacturers Association) and UL standards. Present NEMA and UL standards classify standard NEC one-time or renewable-cartridge fuses as Class H. These fuses are classified at interrupting ratings of up to 10,000 A.
- 5-19 Cartridge-fuse classifications based on existing UL requirements at IC (interrupting capacity) ratings above 10,000 A RMS are Class J, L, G, or K. These fuses are called high-interrupting-capacity fuses, indicating an interrupting rating at some value between 10,000 and about 300,000 A RMS. Class J and Class L fuses are current-limiting, high-interrupting-capacity fuses. The interrupting ratings are marked on the label.
- 5-20 Class J fuse dimensions are different from standard Class H cartridge fuses of the same voltage and current ratings. They require special fuseholders that will not accept noncurrent-limiting fuses. This requirement complies with NEC Section 240-60(b), which reads in part, "Fuseholders for current-limiting fuses shall not permit insertion of fuses that are not current-limiting." Class J fuses of 60 A or less are ferrule types. Non-ferrule types, from 60 to 600 A, have slots in the fuse knife blades to permit bolted or knife-blade connections to fuseholders, as shown in Figure 5.8 on the left.
- 5-21 Class L fuses are divided into several current classifications, with various blade mounting hole dimensions. The dimensions vary according to fuse size, permitting bolted connection to fuseholders. An example is shown in Figure 5.8 in the center.
- 5-22 Class K fuses have interrupting ratings of 50,000 to 200,000 A RMS at various peak let-through currents and maximum let-through energy conditions. These fuses are divided into three groups; K1, K5, and K9.
- 5-23 All fuses presently listed as UL Class K have the same dimensions as conventional Class H 250 V or 600 V, 0 to 600 A fuses. An example of a Class H fuse is shown in Figure 5.8 on the right. Because of this interchangeable feature, Class K fuses are not labeled current limiting, even though qualifications for K1 fuses closely match the qualifications for Class J fuses.

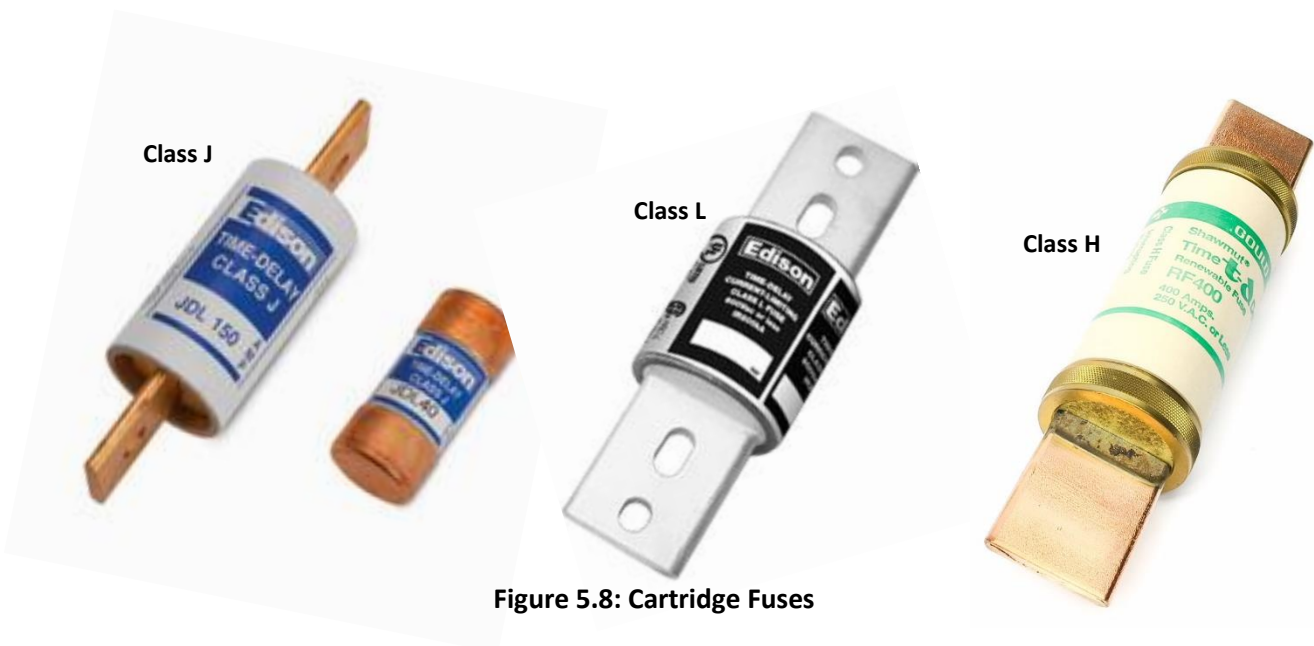

Figure 5.8: Cartridge Fuses



## Installing Cartridge Fuses

5-24 Sometimes fuses require the use of switching devices. The NEC requires that a means of dis-connecting be provided on the supply side of all fuses and thermal cutouts in circuits of more than 150 V to ground. A disconnect is also required for all cartridge fuses in circuits (of any voltage) where the fuses are accessible to anyone other than a qualified person.

**WARNING: Never insert fuses in a live circuit. The arcing that results can burn, gouge, or weld the ferrule or knife blade which reduces the effective contact between the fuse and the clip.**

5-25 Spring clips for ferrule or knife-blade fuses should make a tight contact with fuse terminals over a large area. Do not use damaged clips that cannot provide a good contact surface with the fuse. Follow these suggestions when you insert a fuse into a clip.

- Keep fuse clips, fuse ferrules, and blades clean and smooth across the contact surface. If necessary, use a non-abrasive cleaner to clean contacting parts. Never use sandpaper or other abrasives.
- A ferrule-type cartridge fuse cannot be rotated easily in its clip if the contact is tight. A knife-blade cartridge fuse is difficult to insert if the spring clips make tight contact.
- If spring clips lose their tension or gripping strength, you should replace them. Clamping devices are available to provide tight connection between the fuseholder and the fuse.

5-26 NEC rules on installation of fuses include the following:

- Generally, overcurrent devices (fuses) must be installed so that they are readily accessible. That is, they must be capable of being reached quickly for operation, renewal, or inspection, without requiring those who must have ready access to climb over or remove obstacles, or to resort to portable ladders. An exception to this rule is made when an overcurrent device is used in a busway plug-in unit to tap a branch circuit from the busway.
- Overcurrent devices must be enclosed in cutout boxes or cabinets, unless they are a part of a specially approved assembly which provides equivalent protection.
- Enclosures for overcurrent devices in damp or wet locations must be of a type approved for such locations and must be mounted so there is at least 1/4 inch (6 mm) of air space between the enclosure and the vertical surface on which it is mounted.
- Enclosures for overcurrent devices must be mounted vertically, unless this is impractical.
- Fuses must be located or shielded so that people will not be burned or otherwise injured by fuse operation.
- Although the Code gives maximum heights at which overcurrent protective devices are considered readily accessible, an overcurrent device with a center no more than 6 1/2 feet (2 meters) above the floor or working platform will be satisfactory to most regulating authorities.



## Plug Fuses

- 5-27 A plug fuse has a threaded base that screws into a socket. A familiar household example is shown in Figure 5.9. This kind of fuse is called the Edison-base plug fuse. The plug fuse is usually satisfactory only for home lighting and heating circuits.



Figure 5.9: Edison-Base Plug Fuse

- 5-28 Section 240-50 of the NEC says, "Plug fuses and fuseholders shall not be used in circuits exceeding 125 V between conductors." An exception allows their use in circuits having a grounded neutral and no conductor at over 150 V to ground.
- 5-29 Rarely do you have a branch circuit on which a motor is never connected. With a motor on the circuit, the ordinary plug fuse is not satisfactory. It has very little time delay, and the starting current of any motor will often blow the fuse, especially if the circuit is already partially loaded. Fluorescent lighting often brings about the same condition because of the high starting current.
- 5-30 The dual-element plug fuse eliminates such unnecessary fuse blowing. The dual-element plug fuse works on the same principle as the dual-element cartridge fuse.
- 5-31 Type S fuses are made so that you cannot install a fuse with too large a capacity. Thus, bridging and tampering is practically impossible when this kind of fuse is used. The Type S fuse has the same electrical features as an ordinary plug or dual-element cartridge fuse. Type S fuses can be installed in any Edison-base fuseholder by using a screw-in adapter that locks in place. An example of this fuse and adapter is shown in Figure 5.10. One adapter is for fuses of 0 to 15 A, a second is for fuses of 16 to 20 A, and a third is for fuses of 21 to 30 A. Type S fuses will not fit adapters of the wrong size.



Figure 5.10: Type S Plug Fuse and Adapter

## Plug Fuses (continued)

5-32 Sections 240-50, 51, 52, 53, and 54 of the NEC define the minimum standards for plug fuses and fuseholders. Note that the Edison-base fuse is mentioned only as a replacement item in existing installations. The Type S fuse shall be used in new installations of up to 30 A.

## Glass-Tube Fuses

5-33 Glass-tube fuses are used as supplementary protection for fixtures and equipment. They are used in test equipment to protect the meter circuit. They are also used in automotive circuits and in low-voltage control circuits operating at voltages of less than 250 V. Single-element, dual-element, and pigtail glass-tube fuses are shown in Figure 5.11.

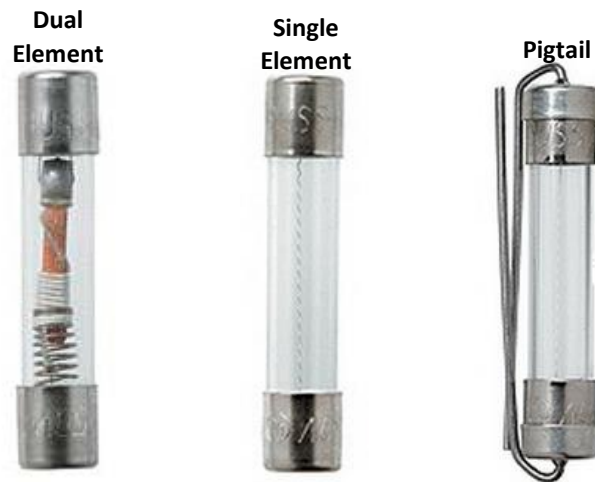

Figure 5.11: Glass-Tube Fuses

5.34 Some glass-tube fuses have metal end caps that fit into a fuseholder. However, the pigtail fuse has two leads that are soldered directly into a circuit. The pigtail fuse is a type of single-element fuse.

5.35 Special fuseholders available for use with glass-tube fuses include the spring-clip type and the tubular type. With the tubular type, the fuse is inserted in a plastic tube. A cap is placed over the top and twisted to lock it in place. Both kinds of fuseholders are shown in Figure 5-12.



Figure 5.12: Glass-Tube Fuseholders

## **Glass-Tube Fuses (continued)**

- 5-36 Two kinds of glass-tube fuses are available.
- A single-element fuse blows instantly when an overload or a short circuit occurs.
  - A dual-element fuse has a time-delay element. This element allows a brief overload in the circuit before the fuse blows. Typically, dual-element fuses are used in circuits containing fractional-horsepower motors, relays, and solenoids.
- 5-37 Supplementary overcurrent protection is used in appliances or other equipment to provide individual protection for specific components. Such protection is not branch circuit protection, and the NEC does not require supplemental overcurrent protective devices to be readily accessible for maintenance.
- 5-38 Typical examples of supplemental overcurrent protection include fuses installed in fluorescent lighting fixtures, movie projectors, and cooking and heating equipment. Fuses used for supplemental overcurrent protection are rated lower than the fuses for the branch circuit supplying the equipment as a whole.

## **Kinds of Circuit Breakers**

- 5-39 A circuit breaker resembles an automatic light switch. It cuts off the current when it becomes too great. Some circuit breakers have a trip-indicator window that will show a red flag when the breaker is tripped. Most breakers trip to a central lever position. Once the cause of the overload has been corrected, the breaker must be reset by switching it to the OFF position, then ON.
- 5-40 A circuit breaker is a device for interrupting the current in a circuit under normal or abnormal conditions. Under normal continuous-current rating, a circuit breaker is a single switching device. When the current exceeds the normal rating, either on overload or short circuit, the circuit breaker acts as an automatic overcurrent protective device.
- 5-41 The function of the circuit breaker is equivalent to the function of a switch in combination with a fuse. The selection and application of circuit breakers depends upon understanding the characteristics of available types and their accessory devices.
- 5-42 A circuit breaker (sometimes abbreviated CB) automatically interrupts the current when the conditions are abnormal. Unlike a fuse, however, the circuit breaker operates without damage to itself. The circuit breaker mechanism is set to interrupt the current at a specific overload value. It can also interrupt a short-circuit current. In contrast, a manual switch will not automatically interrupt a short-circuit current.

## Kinds of Circuit Breakers (continued)

5-43 The automatic action of a circuit breaker can be accomplished in several ways. The most common ways are:

- Magnetic action
- A combination of thermal release and magnetic action
- Hydraulic or pneumatic means.

## Magnetic Circuit Breakers

5-44 A magnetic circuit breaker is used in circuits that must open immediately when a fault occurs. A simple diagram of the magnetic circuit breaker is shown in Figure 5.13. The diagram at the left shows the circuit breaker under normal conditions. The diagram at the right shows how the circuit breaker trips when the current becomes too high.

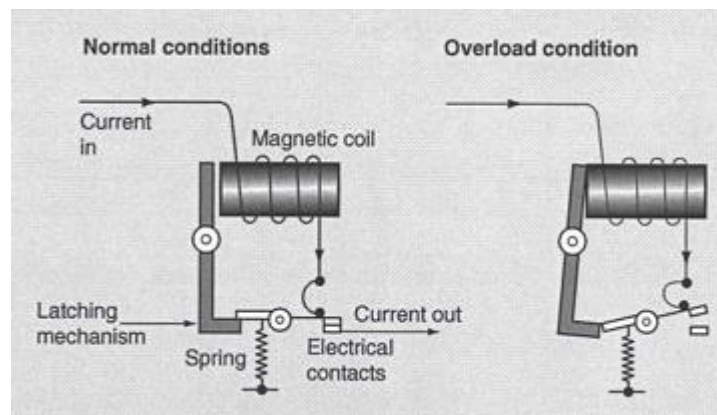

Figure 5.13: Magnetic Circuit Breaker

5-45 The combination circuit breaker has both a thermal strip and a magnetic coil. The thermal strip provides a time delay for small, momentary overloads. The magnetic coil provides instantaneous trip on high overloads or short-circuit currents. The magnetic coil also protects the bimetallic strip from overheating.

5-46 Figure 5.14 is a simple diagram of the thermal-magnetic circuit breaker. The diagram at the left shows the circuit breaker during normal operation. The diagram at the right shows the circuit breaker as it trips and interrupts the circuit.

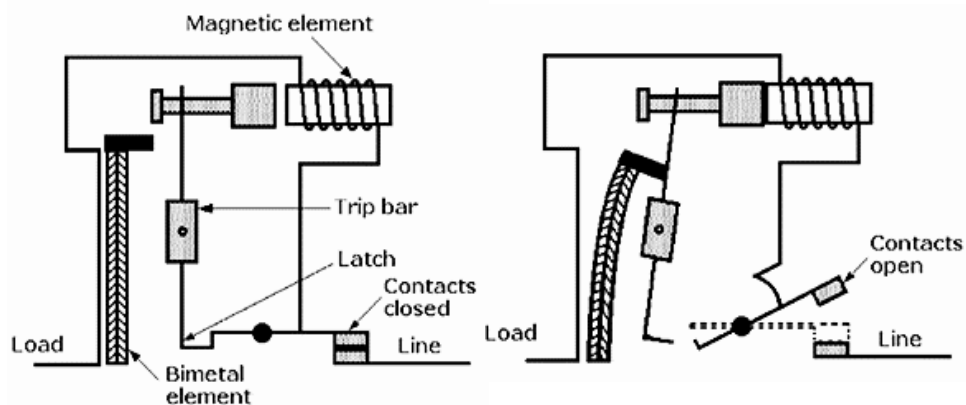

Figure 5.14: Thermal-Magnetic Circuit Breaker

## Ambient-Compensated Circuit Breakers

- 5-47 The ambient-compensated circuit breaker has two bimetallic strips. They are connected physically so that one strip compensates for changes in the ambient temperature. Thus, the action of the circuit breaker depends only on the temperature increase due to the current and not on the temperature of the surroundings.
- 5-48 The action of this circuit breaker is shown in Figure 5.15. You can see that both bimetallic strips bend with an increase in ambient temperature, but only the overload element responds to the current. The circuit breaker trips only when the excessive current through the overload strip causes it to bend more than the compensating strip.

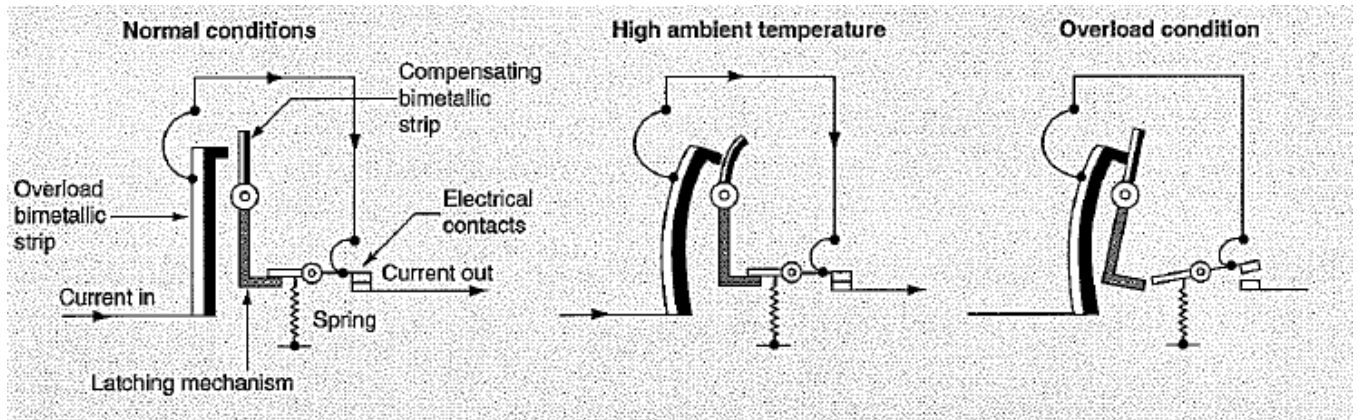

Figure 5.15: Ambient-Compensated Circuit Breaker

- 5-49 The ambient-compensated circuit breaker is used in areas where high temperatures occur. Examples include areas where metals are melted, areas near ovens, and boiler rooms.

## Molded-Case Circuit Breakers

5.50 The molded case of a circuit breaker provides the physical means of positioning the breaker components, and it protects the working parts from damage and contamination. The molded case also protects people from contact with energized components in the breaker. Figure 5.16 shows the internal view of a molded-case circuit breaker.



**Figure 5.16: Molded-Base Circuit Breaker**

5-51 A wide range of molded-case circuit breakers is available, with many options. Some examples are shown in Figure 5.17. For example, some circuit breakers provide short-circuit protection only. These breakers can be used on motor circuits where overload protection is provided by the motor starter or built into the motor.



**Figure 5.17: Typical Molded-Case Circuit Breakers**

5-52 Molded-case circuit breakers can be used in any low-voltage (less than 600 V) electrical circuit where protection is required, including main service and feeders as well as branch circuits. They are found in switchboards, panelboards, control centers, combination starters, and in individual enclosures.

5-53 Potential difference is the most important consideration in selecting a molded-case circuit breaker. Devices for AC service are available in ratings of 120/240, 240, 277, 480, and 560. Molded-case breakers for DC service are available in 120 and 240 V ratings.

## Molded-Case Circuit Breakers (continued)

- 5-54 The interrupting ability of molded-case circuit breakers is greater on ac than on dc. For example, a 560 V circuit breaker may have an interrupting capacity of 15,000 A AC at the rated potential difference. When used in a 250 V DC circuit, however, the same circuit breaker can interrupt only 10,000 A.
- 5-55 *Interrupting capacity* is the fault current a circuit breaker can interrupt without damage to itself. Circuit breakers can be rated at anywhere from 5,000 through 150,000 A of interrupting capacity. If equipped with current-limiting devices, a circuit breaker's interrupting capacity can be increased to 200,000 A. The breaker must be rated for sufficient interrupting capacity to interrupt the maximum amount of current the electrical system can deliver under "bolted-fault" (short-circuit) conditions.
- 5-56 Where a molded-case circuit breaker is used for motor branch-circuit protection, its rating cannot be less than 115% of motor full-load current rating. However, enough time delay must be provided to start the motor. This provision usually requires using a breaker rated at 150 to 250% of the motor's full-load current. In such an application, the breaker serves both as the disconnect switch and as the fault protection for all circuit components.
- 5-57 Remember that circuit breakers are basically protective devices rather than service equipment. A circuit breaker's mechanical life is rated in thousands of operations, rather than hundreds of thousands. Applications where a large number of mechanical operations is required should be reviewed to see if a contactor can be placed between breaker and load to perform repetitive mechanical operations.
- 5-58 Molded-case breakers are relatively trouble-free devices, requiring little maintenance. For the most part, the only maintenance required is to see that all conductor terminals are tight and free from corrosion, and that the breaker is dry and free from accumulated dirt and dust.
- 5-59 Most circuit breakers require no internal servicing. An exception is the trip unit on breakers in large frame sizes, which is replaceable. Periodic inspection should be made to make sure the trip unit's hold-down bolts are tight.
- 5-60 Molded-case circuit breakers should be kept clean so that heat can be dissipated properly. Do not break any seals on these units. Electrical connections must be kept tight so that heat is not introduced to the thermal overload element.
- 5-61 A molded-case circuit breaker consists essentially of two separate elements:
- **A set of contacts.** The contacts are connected to a mechanical linkage for manual operation as a switch.
  - **An overload-sensing device.** Normally, the time-delay overload device is thermal, and the instantaneous overload device (if any) is magnetic.
- 5-62 Manually opening and closing the main contacts of the circuit breaker will not move any of the mechanical joints in the overload device. After a period of inactivity these become stiff or inoperable. The only way to check this condition and eliminate the stiffness is to trip the breaker electrically. You may need to trip the breaker as often



as every 6 months, or as seldom as every few years. The frequency depends on conditions where the breaker is installed.

### Molded-Case Circuit Breakers (continued)

5-63 Periodically, a molded-case circuit breaker should be subjected to a current equal to 300% of the breaker rating. You should measure the time it takes for this current to trip the breaker, and compare it to the time specified by the manufacturer. If the circuit breaker has an instantaneous element, you should check it for pickup according to the manufacturer's specifications.

### Low-Voltage Power Circuit Breakers

5-64 A low-voltage power circuit breaker operates at 600 V or less. The air power circuit breaker shown in Figure 5.18 can be used in an electric circuit to interrupt fault currents, to provide overload protection, or to open and close the electric circuit. A low-voltage power circuit breaker has two elements:

- A set of contacts with a mechanical linkage to open or close the electric circuit rapidly
- An abnormal-condition-sensing element, called a *trip device*.

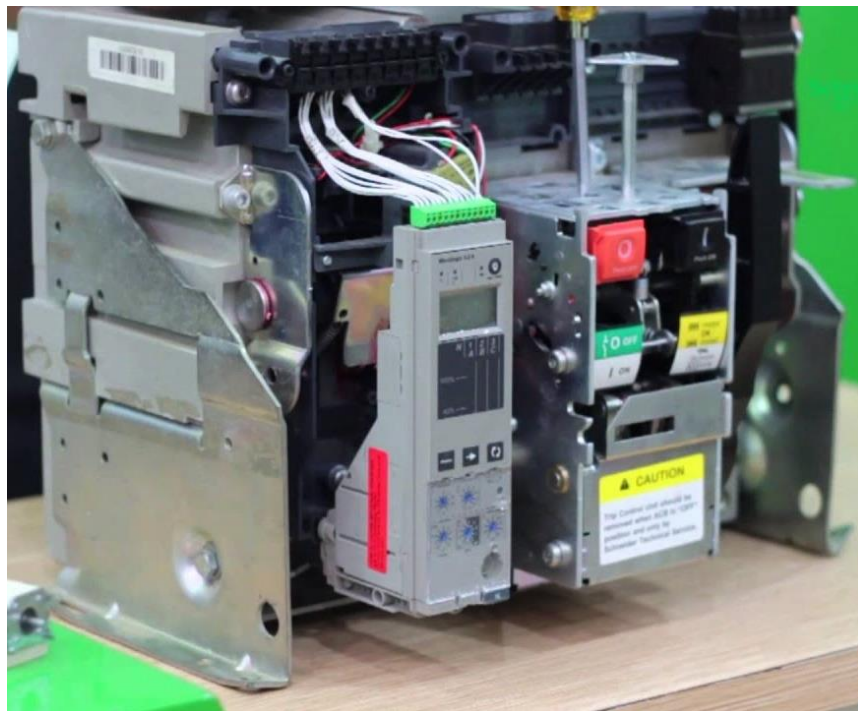

Figure 5.18: Air Power Circuit Breaker



## Low-Voltage Power Circuit Breakers

- 5-65 This circuit breaker can be equipped with accessories to provide electrical operation, remote operation, reverse-current tripping, shunt tripping, and under-voltage tripping. It may have auxiliary contacts for alarms or indicating lamps. Low-voltage power circuit breakers may have continuous-load ratings of 15 to 6000 A. Interrupting capacities range from 15,000 to 130,000 A at 240 V AC.
- 5-66 An overload-series tripping device is sometimes magnetic. In these devices, time delay is accomplished by using a dashpot or a ratchet device. Current in the trip coil attracts the armature. The dashpot slows the motion of the armature, producing a time-delayed tripping action. However, these magnetic devices have largely been replaced by electronic units.
- 5-67 Low-voltage circuit breakers are available with several kinds of resetting devices. One of these devices is the stored-energy mechanism. This mechanism has springs that are compressed either manually or electrically to provide quick reclosing of the breaker contacts. The high-speed closing extends contact life by reducing arcing during reclosing of the contacts.
- 5-68 The stored-energy mechanism of the air breaker shown in Figure 5.19 has a mechanism that compresses a spring. The spring stores enough energy to close and latch the breaker. The spring is held in its fully compressed position by a latch until the latch is released for the closing operation. The spring then drives the breaker contacts closed.

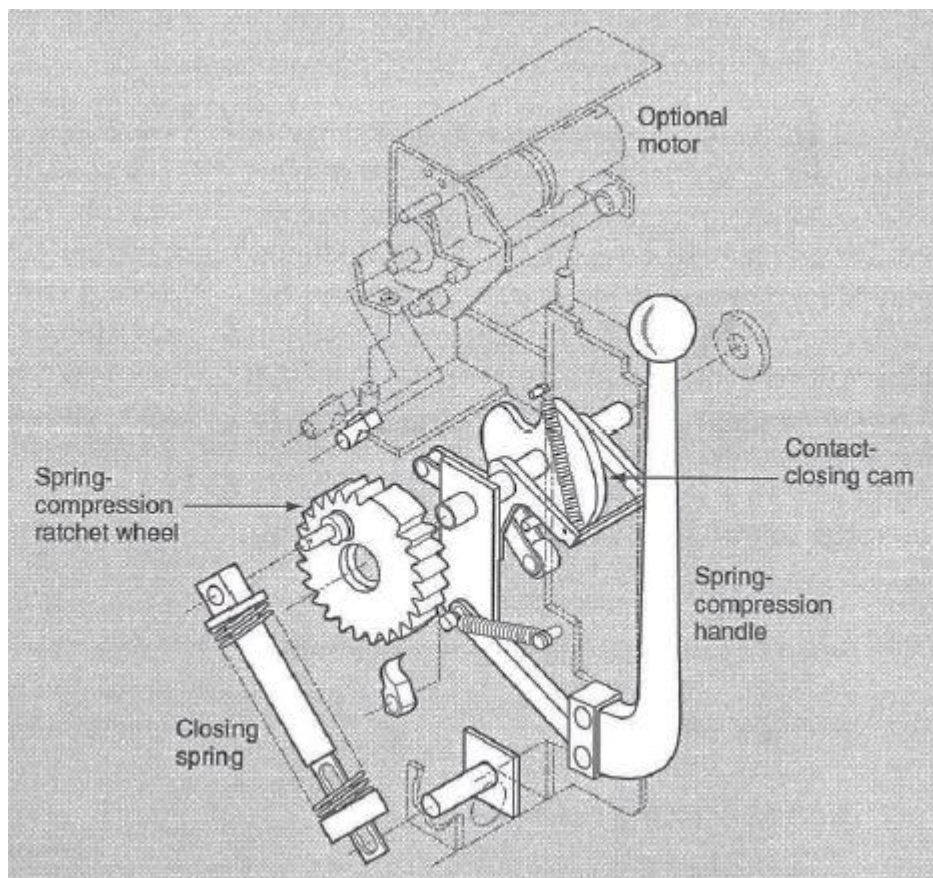

Figure 5.19: Stored-Energy Mechanism

## Low-Voltage Power Circuit Breakers (continued)

- 5-69 One of the support points of the closing mechanism is a roller that is held in place by a trip latch. Release of this latch allows the mechanism to collapse. The breaker contacts then open and cannot be reclosed except by the action of the compressed spring. The spring cannot expand and close the breaker contacts unless the operator has taken action to compress it.
- 5-70 A manual spring-driven circuit breaker has a handle on the front to compress the spring. An indicator on the circuit breaker indicates "Spring Charged" when the spring is compressed and able to close the breaker contacts. The breaker may then be manually closed by pushing a close button. It may be electrically closed by a remote contact which energizes a latch-release coil.
- 5-71 Some circuit breakers are equipped with a fractional-horsepower, high-speed universal motor and a ratchet mechanism to compress the springs. The compression takes about one second. The motor drives a gear-and-ratchet unit that delivers high torque to the spring-compressing mechanism. The contact-closing operation works only after the spring is fully compressed. The operation can be controlled electrically from a remote source or manually by a close button on the circuit breaker itself.

## Circuit Breaker Tripping

- 5-72 A series trip is a direct-acting tripping device. It actually carries the load current and normally uses the magnetic attraction of a plunger or armature to trip the circuit breaker. The magnetic attraction is slowed by a dashpot to achieve a time-delay operation. Series trip devices have largely been replaced by electronic trip devices.
- 5-73 circuit breaker tripping device can be equipped to provide three time-current characteristics, either singly or in combination. The three characteristics are listed below:
- **Long time delay.** This characteristic is designed to provide ordinary overload protection. The tripping time is measured in seconds or minutes.
  - **Short time delay.** This characteristic is designed for protecting against fault currents and short circuits. The tripping time is measured in numbers of ac cycles.
  - **Instantaneous trip.** This characteristic provides instantaneous short-circuit protection. There is no time delay.

## Circuit Breaker Tripping (continued)

5-74 Causes of malfunction of the circuit breaker time-delay components depend on time and severity of duty. Common causes of malfunction generally fall into the following three categories for series devices

- Loss of oil or air seal in the dashpot, physical damage, aging of seals, or physical wear
- Clogging of parts (orifices) by foreign matter or oil sludge that forms as a result of environmental conditions and aging of oil
- Freezing of components in the plunger assembly due to corrosive atmospheres and long periods of inoperation.

When electronic time-delay devices fail, it is usually the result of an electronic component failure.

5-75 Of all the possible faults, improper delay in opening when an overload occurs is the most dangerous. Normal operating procedures and careful maintenance inspections will reveal most of the conditions that are likely to interfere with circuit protection. However, the only way to know for sure whether the circuit breaker will recognize an abnormal circuit condition and operate properly is to test it. The test is done by creating an overload.

5-76 The following conditions may render a low-voltage circuit breaker unfit for service:

- Frozen or jammed contacts and/or mechanism
- Improper calibration
- Improperly set trip element
- High contact resistance
- Mechanical linkage problems
- Open contacts or damaged series relay
- High resistance or arcing fault, often caused by loose or improper fit between primary fingers and bus contacts
- Broken or cracked arc chutes
- Loose parts
- Accumulated dirt
- Contaminated dashpot oil
- electronic component failure

These can be caused by a variety of conditions, including moisture, corrosion, abuse, wear, vibration, and improper maintenance.

## Circuit Breaker Reset and Fuse Replacement

- 5-77 The proper selection of current-limiting fuses and circuit breakers is essential in electrical systems. If they are to function as designed, fuses must always be replaced with the type and size recommended by the equipment manufacturer.
- 5-78 When a fuse blows or a circuit breaker trips, something is wrong. Usually it is an overloaded circuit, a short circuit, or a ground fault. Never try to start the current in the circuit flowing again until the problem has been corrected. Many serious accidents have occurred because hidden damage to the electrical system was not corrected before the system was re-energized. Determine the source of the problem and remedy the situation. A brief procedure for following up the trip of a circuit breaker follows.
- 5-79 If the circuit breaker protecting a motor control circuit has tripped, a fault has occurred and the excess current might have damaged the motor controller. To ensure future safe operation, several steps should be taken by a qualified person before the system is returned to service. These steps are as follows:
1. Turn off and lock out all power supplying the equipment. There may be more than one power supply to be turned off.
  2. Examine the circuit breaker for external evidence of damage. (Most circuit breakers are sealed and cannot be examined internally.) Follow the circuit breaker manufacturer's instructions or the NEMA standards for circuit breakers.
  3. Inspect all terminals and conductors for discoloration, melting, or other signs of arcing, and replace all damaged parts.
  4. Inspect the motor starter for damage to its contacts, contact springs, insulation system, electrical connections, overload relay, and other parts. Replace the overload relay if burnout of the heater element has occurred.
  5. After replacing all damaged equipment, inspect the motor controller and manually check all moving parts for freedom of motion.

## Chapter 5 Exercise

Circle the appropriate letter next to the correct answer.

1. Which of the following should be used in removing or installing cartridge fuses?
  - a. Fingers
  - b. Non-conducting tongs
  - c. Padlock and hasp
  - d. Pliers
  
2. Dual-element cartridge fuses are designed mainly for \_\_\_\_\_.
  - a. High-voltage installations
  - b. Home-lighting circuits
  - c. Motor-circuit protection
  - d. Supplementary protection
  
3. Standard NEC one-time and renewable-cartridge fuses rated at up to 10,000 A are classified as \_\_\_\_\_.
  - a. Class G
  - b. Class H
  - c. Class J
  - d. Class K
  
4. According to the NEC, plug fuses may not be used in circuits exceeding \_\_\_\_\_ V between conductors.
  - a. 60
  - b. 125
  - c. 250
  - d. 600
  
5. Glass-tube fuses may not be used in \_\_\_\_\_.
  - a. Automotive circuits
  - b. High-voltage control circuits
  - c. Low-voltage control circuits
  - d. Test equipment

## Chapter 5 Exercise (continued)

Circle the appropriate letter next to the correct answer.

6. The action of an ambient-compensated circuit breaker depends only on the \_\_\_\_\_.
- a. Action of the magnetic coil
  - b. Bending of the compensating strip
  - c. Temperature increase due to current
  - d. Temperature of the surroundings
7. The interrupting ability of molded-case circuit breakers is \_\_\_\_\_.
- a. Determined by the size of the unit
  - b. Greater on AC than on DC
  - c. Less on AC than on DC
  - d. The same on AC and DC
8. The function of a dashpot is to \_\_\_\_\_ the motion of the armature in a circuit breaker.
- a. Amplify
  - b. Prevent
  - c. Slow down
  - d. Speed up
9. What kind of delay provides a tripping time measured in AC cycles?
- a. Instantaneous
  - b. Short time
  - c. Medium time
  - d. Long time
10. When a circuit breaker trips, what is the first step you should take?
- a. Inspect for terminal and conductor damage
  - b. Replace the circuit breaker
  - c. Reset the circuit breaker and try to restart
  - d. Turn off all power to the equipment

## Summary

A fuse is a kind of overcurrent protective device. It is designed to protect a circuit and surrounding materials and people from harm by excess current. It does so by opening and breaking the circuit if too much current flows through it.

Cartridge fuses today are one-time use devices. Dual-element cartridge fuses have two elements. One provides a time delay during overloads, the other allows the fuse to blow immediately in case of a short circuit. A current-limiting fuse acts faster than an ordinary fuse, thus limiting the amount of energy allowed into the circuit. A plug fuse screws into a socket. Standard plug fuses are usually limited to home use. The dual-element plug fuse is usually used in plant applications. Glass tube fuses provide supplementary protection for fixtures and equipment. They are available as single-element and dual-element fuses. Such fuses are rated lower than the fuses for the branch circuit supplying the equipment as a whole.

Circuit breakers are another type of protective device. They are designed to interrupt the current in a circuit automatically when conditions are abnormal.

A magnetic circuit breaker has both a thermal strip and a magnetic coil. The strip provides a time delay for small, brief overloads. The coil opens the contacts immediately on high overloads or short-circuit currents. The ambient-compensated circuit breaker has two bimetallic strips. Both bend in response to an increase in the ambient temperature, but the overload strip bends farther than the compensating strip in response to excessive current.

Molded-case circuit breakers provide both overload and short-circuit protection. Their interrupting ability is greater on ac than on dc. Low-voltage power circuit breakers can interrupt fault currents, provide overload protection, and open and close a circuit. Time delay is accomplished by using a dashpot or ratchet device or an electronic device.

If a fuse blows or a circuit breaker trips, you must find out why. Turn off and lock out all power supplying the equipment and inspect for damage. Always replace fuses with the recommended type and size.





# Chapter 6: Motor Protection

## In This Chapter:

The Importance of Motor Protection

Motor-Feeder Protection

Feeder Size

Branch Circuits

Motor Branch-Circuit Overcurrent Protection

Motor-Running Overcurrent Protection

Inherent Thermal Protection

Temperature-Sensing Devices

Current-Sensing Devices

Melting-Alloy Relays

Bimetallic Relays

Selecting Motor Protection

Ambient-Compensated Overload Relays

Single Phasing

Protecting Overload Relays

## Objectives

After completing this manual, you should be able to:

- List the steps in determining the correct rating of the motor feeder protection.
- Explain how to select a thermal overload relay.
- Explain how thermostatic, resistance, and thermocouple detectors work.
- Explain how various relays provide motor protection.
- Define single phasing.

## Terminology

**General-purpose branch circuit:** A circuit that supplies a number of outlets for lighting and appliances

**Individual branch circuit:** A circuit that supplies only one piece of equipment

**Multi-wire branch circuit:** A circuit with two or more ungrounded conductors with a potential difference between them plus an identified grounded conductor

**Thermostatic detector:** A bimetallic thermostat

**Resistance detector:** A loop of precisely calibrated resistance wire that fits between two coils in a stator slot

**Thermocouple detector:** A thermocouple that produces a small potential difference that increases with rising temperature

**Trip-free relay:** A relay that will trip even if the reset pusher is blocked

**Eutectic alloy:** An alloy that melts completely at a specific temperature

**Single-phasing:** A condition in which a three-phase motor continues running after one phase has been lost

**Motor failure is costly, especially if the motor is part of a production line. Motors that are maintained regularly and provided with the proper protective devices are less likely than others to fail.**

**An electrical maintenance worker must know how to select the proper protective devices for the system. This means being familiar with the use and operation of fuses, circuit breakers, relays, and temperature detectors, and understanding how to determine the correct sizes and electrical values from nameplate information, from tables issued by the motor manufacturer, or from the NEC.**

**This chapter begins by explaining the importance of motor protection and some of the ways of protecting motors. It then covers the operating characteristics of various motor-protection devices and selection of the proper devices for the equipment being used.**

## **The Importance of Motor Protection**

6-1 Many different kinds of motors have been developed for many different purposes. Their characteristics vary greatly.

- One kind of motor needs 56 seconds starting time under normal load.
- An oil-well pump motor will suffer serious damage if its rotor locks and the motor is not disconnected from the line within 20 seconds.
- A conveyor-drive motor in a potash processing plant can withstand 35% overload for 30 minutes.
- A hermetic compressor motor may burn up in 3 minutes at a 25% overload.

In each example, the motor requires overload protection. The protective device must allow for the starting-current requirements of each motor, but it must also meet the requirement for protection against excessive overload currents.

6-2 Many applications require special motors that in turn require special protective schemes. Even when familiar "standard" motors are used, it is important to select the proper means of protection.

## Motor Feeder Protection

6-3 Figure 6.1 is a simple diagram of a typical motor circuit. The first protective device is the motor feeder protection. The size of this protective device depends on the number of motors to be connected and their sizes.

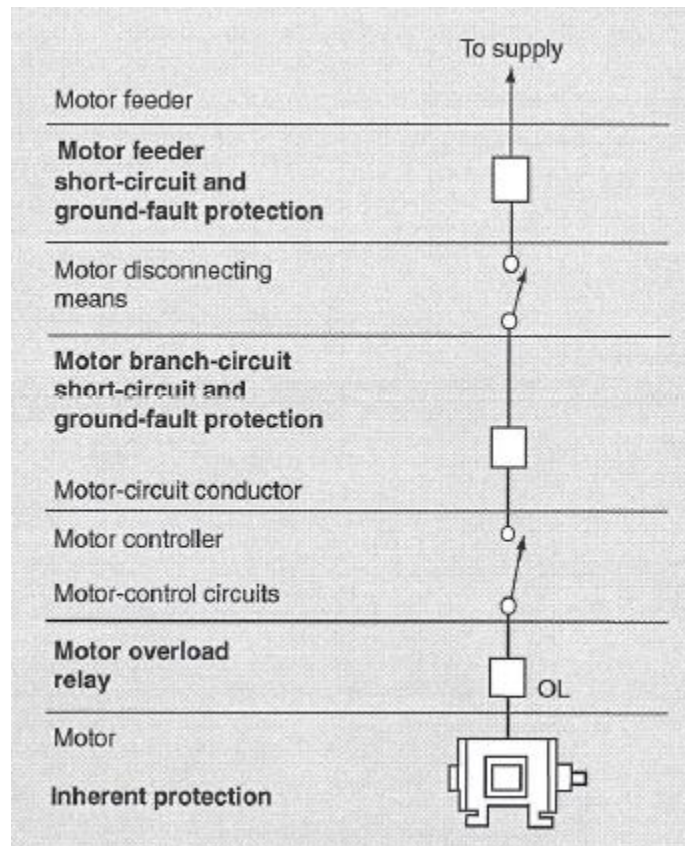

Figure 6.1: Motor Circuit Protective Devices

6-4 If only one motor is connected, the motor feeder protective device is rated the same as the branch-circuit protective device. However, if more than one motor is connected to the feeder, the rating of the feeder protection is determined as explained below.

- Find the highest permitted fuse capacity for all the motors in the circuit. To do this, multiply the full-load current rating of each motor by the percentage listed for that motor in Table 430-52 of the National Electrical Code. Notice that the multiplier depends on the kind of fuse to be installed.
- To the highest current requirement for one motor in the circuit, add the full-load current ratings for all the other motors in the circuit.

6-5 The resulting value is the current rating required for the feeder. If there is no standard-size fuse of that rating, Section 430-62 of the NEC requires using a fuse of the next lower rating. The NEC permits using a fuse with a higher rating in a motor branch circuit if two or more motors must be started at the same time. However, note that larger feeders must be installed to carry the higher current safely.

## Motor Feeder Protection (continued)

6-6 For example, suppose you have a feeder that supplies four 480 V three-phase motors of different sizes, as shown in Figure 6.2. What is the rating of the proper fuses to use in protecting the feeder circuit?

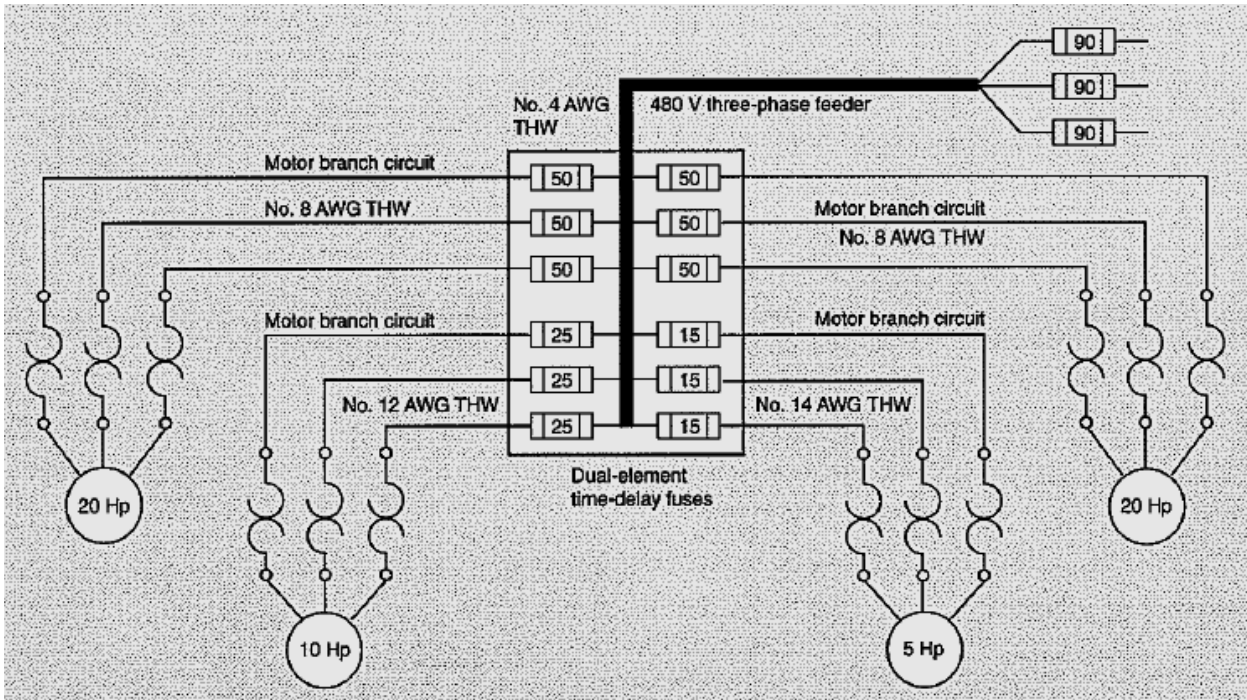

**Figure 6.2: Motor Branch-Circuit Conductors and Protective Devices**

6-7 The full-load current ratings for the motors are listed in Table 430-150 of the NEC. The values are as follows:

20 horse power, three-phase 480 Volt . . . . . 27 Amps

10 horse power, three-phase 480 Volt . . . . . 14 Amps

5 horse power, three-phase 180 Volt . . . . . 7.6 Amps

Both 20 horse power motors draw the same full-load current, but they are treated differently in this problem. For one, you add the fuse rating. For the other, you add the full-load current rating.

6-8 From Table 430-52 of the NEC, you can see that the multiplying factor for a squirrel-cage motor is 175%, if you use dual-element fuses. Therefore, the current requirement for the fuse is 47.25 A for starting this motor.

$$27 \text{ A} \times 175\% = 47.25 \text{ A}$$

Section 430-52 of the NEC permits using a 50 A fuse for this motor.

## Motor Feeder Protection (continued)

- 6-9 In order to calculate the correct current rating of the fuse, add this 50 A to the full-load current rating of all the other motors on the feeder.

$$\begin{array}{r} 20 \text{ hp} = 50.00 \text{ A} \\ 20 \text{ hp} = 27.00 \\ 10 \text{ hp} = 14.00 \\ \underline{5 \text{ hp} = 7.60} \\ \text{Total} = 98.60 \text{ A} \end{array}$$

There is no standard fuse rated at 98.6 A. The NEC requires using the next lower-rated standard fuse in this feeder circuit. The correct fuse is rated at 90 A.

- 6-10 Note that the full-load current of only one 20 hp motor was multiplied by 175%, not both. However, if both 20 hp motors were required to start at the same time, you would have multiplied both full-load currents by 175%. Then both motors would require 50 A fuses. The feeder circuit would then require a 110 A fuse ( $50 + 50 + 14 + 7.6 = 121.6$  A, reduced to the next lower standard fuse value).

## Feeder Size

- 6-11 Section 430-24 of the National Electrical Code requires a feeder rating of 125% of the full-load current of the motor with the highest current, plus the full-load current of the other motors. In the example shown in Figure 6.2, the feeder size is calculated in the following way:

$$\begin{array}{r} 20 \text{ hp} (1.25 \times 27) = 33.75 \text{ A} \\ 20 \text{ hp} = 27 \\ 10 \text{ hp} = 14 \\ \underline{5 \text{ hp} = 7.60} \\ \text{Total} = 82.35 \text{ A} \end{array}$$

- 6-12 The correct feeder conductor size is No. 4 AWG copper, if the wire is covered with insulation coded THW (thermoplastic insulation, resistant to heat and water). Table 310-16 of the NEC lists the allowable current for this conductor as 85 A.
- 6-13 If both 20 hp motors must be able to be started together, the required capacity of the feeder would be 89.1 A. In this case, the next size conductor would be required—No. 3 AWG copper, covered with THW insulation. The allowable current for this conductor, listed in Table 310-16, is 100 A.
- 6-14 The NEC provides for determining the current requirements of motors of various sizes. Whenever the full-load current rating of a motor is used for determining the current capacity of overcurrent devices, conductors, and switches, you should use the values listed in NEC Tables 430-147, 430-148, 430-149, and 430-150.

## Branch Circuits

6-15 A *branch circuit* is the portion of a wiring system that extends from the final overcurrent device to the outlet. A device not approved for branch-circuit protection, a thermal cutout or a motor overload protective device, for example, is not considered to be an overcurrent device protecting the circuit. Figure 6.3 is a simple diagram of a branch circuit. The circuit breakers are the final overcurrent devices protecting the circuit. The motor control box has overload relays for motor protection, but they are not overload protective devices for the branch circuit. The overload relays protect the motor only.

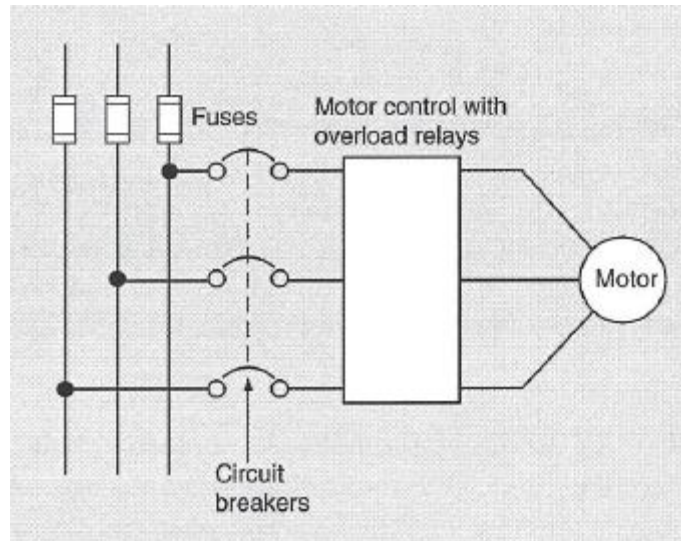

**Figure 6.3: Branch-Circuit Protection**

- 6-16 A *general-purpose branch circuit* is a circuit that supplies a number of outlets for lighting and appliances. This circuit is typical of the branch circuits found in homes and offices for general lighting and for wall outlets.
- 6-17 An *individual branch circuit* is a circuit that supplies only one piece of equipment. For example, an individual branch circuit might supply a bench grinder or a single outlet. A duplex receptacle actually consists of two outlets on a single frame, and is therefore not intended for use on an individual branch circuit.
- 6-18 A *multi-wire branch circuit* is a circuit having two or more ungrounded conductors with a potential difference between them, plus an identified grounded conductor. The potential differences between the grounded conductor and each ungrounded conductor must be equal. In addition, the grounded conductor must be connected to the neutral conductor of the system.

## Branch Circuits (continued)

6-19 An example of a multi-wire branch circuit is the familiar 120/240 V single-phase system shown in the upper diagram in Figure 6.4. The potential difference between the two ungrounded conductors is 240 V. The potential difference between the grounded conductor and each ungrounded conductor is 120 V. The three-phase four-wire circuit is another example of a multi-wire branch circuit. It is shown in the lower diagram in Figure 6.4. It meets the same basic requirements as the single-phase circuit.

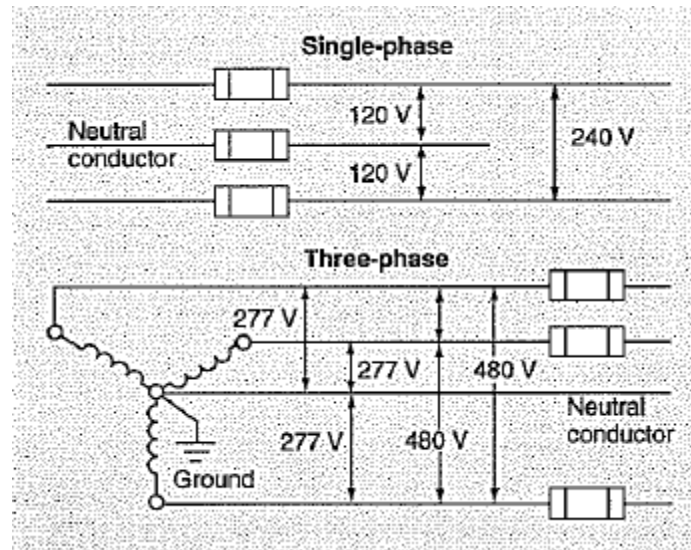

Figure 6.4: Multi-Wire Branch Circuits

- 6-20 Section 210-3 of the NEC states that branch circuits must be rated in accordance with the maximum permitted ampere rating or setting of the overcurrent device. The rating for other than individual branch circuits must be: 15, 20, 30, 40, and 50 A. If conductors of higher ampacity are used for any reason, the ampere rating or setting of the specified overcurrent device determines the circuit rating.
- 6-21 This Section means that the conductor must have a current-carrying capacity that is not less than the rating or setting of the overcurrent device. However, the size of the conductor does not determine the circuit rating. For example, a circuit wired with No. 10 AWG copper wire is considered a 15 A circuit, even though the wire can carry 30 A safely.

## Motor Branch-Circuit Overcurrent Protection

- 6-22 Looking back to Figure 6.1, you can see that the next overcurrent protective device is the motor branch-circuit overcurrent protection. This overcurrent protective device may be either a circuit breaker or a fuse. The maximum allowable fuse rating is determined from Table 430-52 in the NEC. The motor's full-load current is multiplied by the percentage listed in the table. The percentage is based on the type of motor and its code letter, and on the kind of fuse to be installed.
- 6-23 For example, a 20 hp motor with code letter H, operating on 480 V, has a full-load current rating of 27 A. The rating of the overload protection depends on what kind of device is installed. The four possibilities are listed in Table 6-1. Notice that the size of the wire does not depend on the kind of overcurrent protection installed. The wire size is based on 125% of the motor's full-load current.

**Table 6-1: Circuit Protection and Conductors for a Motor Rated at 27 A Full-Load**

Kind of Circuit Protection	Percentage x 27 = (Table 430-52)	Maximum Current Allowable (A)	Maximum Rating Allowable (A) (Section 240-6)	Maximum Current (Copper, THW) (Table 310-16)
Nontime-delay fuse	300	81.00	90	No. 8 AWG
Dual-element fuse	175	47.25	50	No. 8 AWG
Instantaneous-trip breaker	700	189.00	200	No. 8 AWG
Inverse-time circuit breaker	250	67.50	70	No. 8 AWG

## Motor-Running Overcurrent Protection

- 6-24 Whenever the current rating of a motor is used in determining the ampacity of conductors, switches, or branch-circuit overcurrent devices, the values in NEC Tables 430-147, 430-148, 430-149, and 430-150 are used instead of the actual current rating marked on the motor nameplate. The selection of motor-running overcurrent protection, however, must be based on the current rating listed on the nameplate.
- 6-25 The motor-running overcurrent protective device is usually an overload relay. This device is shown just above the motor in Figure 6.1. The motor overload relay (OL) opens the motor circuit on overloads. Some overload relays do not protect the motor against short circuits. Section 430-40 of the NEC requires branch-circuit fuses or circuit breakers in such cases.
- 6-26 To select overload units for most applications, you must determine the rated full-load current from the motor nameplate. Then you must locate the proper selection tables, based on the class, type, and size of the equipment involved. The proper overload unit number will be found adjacent to the range of full load currents in which the rated current falls.



- 6-27 The table for the selection of overload relay units is found on the inside of the motor starter enclosure cover. Tables are also given in the manufacturer's catalog for a particular starter. Always refer to the tables from the manufacturer of the motor starter when selecting overload relay units.
- 6-28 Thermal overload relays selected from the tables will provide a trip current of 101 to 125% of motor full-load current for many single-speed, normal-torque, 60 Hz motors. Since full-load current ratings of different makes and types of motors vary so much, these selections may not always be suitable. Whenever possible, thermal units should be selected from standard tables on the basis of the fullload currents and service factors listed on the nameplates.

### **Inherent Thermal Protection**

- 6-29 The last of the protective devices shown in Figure 6.1 is the *inherent thermal protection*, which senses motor temperature. It is part of the motor's *control* circuit rather than the *power* circuit. Motor current does not flow through this device.
- 6-30 Motors can fail in many ways. Usually, high temperature does the damage. The life of the insulation on electrical machinery is related directly to temperature. Even with an operator in constant attendance, sudden and dangerous rises in motor temperature may go undetected.
- 6-31 There are many causes of overheating in motor windings. Some of these include overloading, loss of ventilation, low motor voltage, and too frequent starting. The amount and the rate of temperature rise vary considerably. Proper protective devices respond to the first sudden rise caused by real trouble.
- 6-32 A reliable way to guard against damaging heat is to provide each motor with built-in temperature-sensing devices. These devices can trigger an alarm or take the motor off the line if the temperature rises too high. Specific kinds of devices will be covered in the next section.
- 6-33 Temperature-monitoring devices are easy to add to existing motors. They are sealed to protect them against dirt and moisture. Whether the device is direct-acting or operates through a remote device, this is the most foolproof way to protect a motor.

## Temperature-Sensing Devices

- 6-34 Protection against overcurrent heating of a motor can be provided either by a *temperature-sensing device* or by a *current-sensing device*. The temperature-sensing device offers better protection than the current-sensing device, because it actually monitors the motor's temperature. Current-sensing devices, including fuses, circuit breakers, relays, and other remote control equipment, protect the power system rather than the motor itself. The motor may overheat because of conditions not detectable by a device installed outside the motor.
- 6-35 Three kinds of temperature detectors are used in motor windings—*thermostatic*, *resistance*, and *thermocouple*.
- 6-36 **Thermostatic detectors.** Thermostatic detectors are sealed bimetallic thermostats that are tied securely against the end turns of the motor winding, as close as possible to the "hot spot." This kind of detector has three key characteristics:
- The setting at which the thermostat operates is built in and cannot be adjusted.
  - There is only one possible contact arrangement. A single contact that either opens or closes upon a rise in temperature.
  - The thermostatic detector gives no indication of the actual temperature or of the rate of rise. All the device tells you is that the winding temperature is somewhere above or below the thermostat's operating point. The control circuit consists only of the thermostat contact in series with a relay that trips the motor breaker.
- 6-37 One version of the winding thermostat is shown in Figure 6.5. Notice the action of the bimetallic strip, shown in the internal views. The photograph shows a typical thermostat that would be installed in a motor winding. The circuit diagram shows how the thermostat is connected in the motor-control circuit.

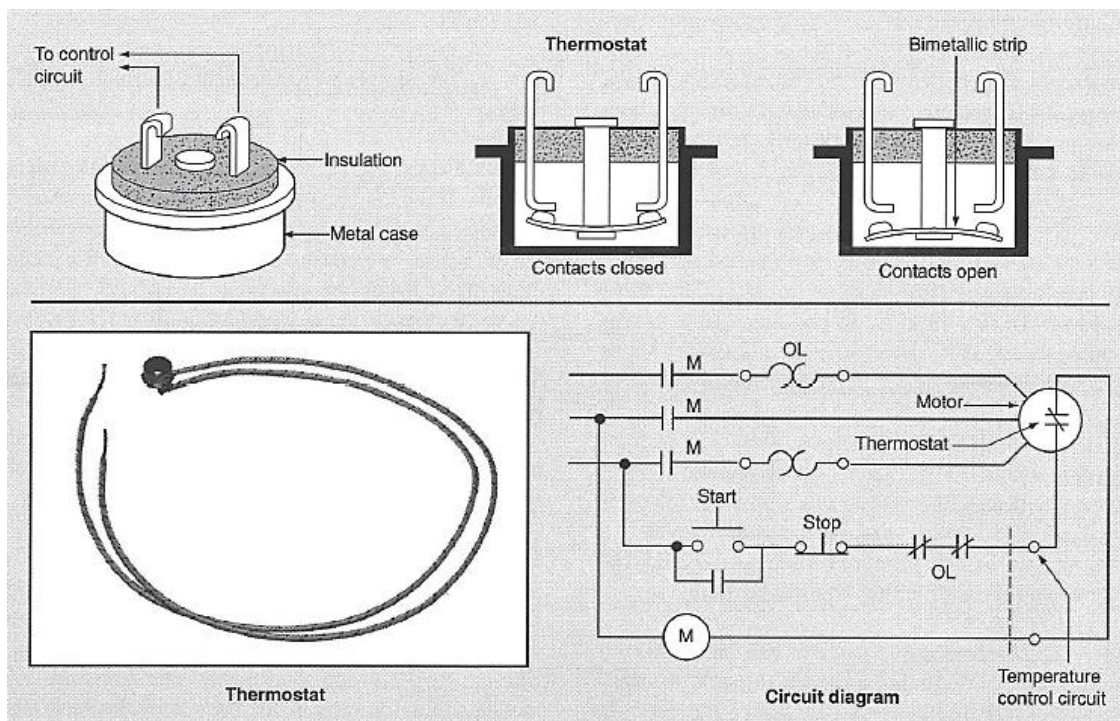
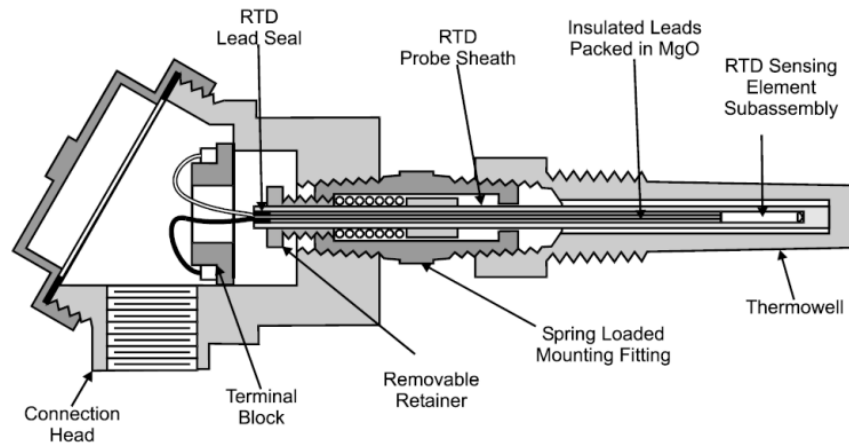

Figure 6.5: Motor-Winding Thermostat

## Temperature-Sensing Devices (continued)

6-38 **Resistance detectors.** For large motor windings, the resistance temperature detector, shown in Figure 6.6, is the most common thermal protective device. The instrument used with this detector is a temperature indicator, not just a switch. It can therefore inform an operator of the actual winding temperature at any time. The probe of the resistance detector is a length of precisely calibrated resistance wire enclosed in a protective shield. It fits through a hole in the motor case, so that it measures the temperature of the motor windings.



**Figure 6.6: Resistance Temperature Detector**

- 6-39 Several resistance detectors are usually provided in a single motor. They are spaced to ensure response to temperature changes in each of the three phases of the winding. Such changes cause corresponding changes in detector wire resistance. These in turn are transmitted to a metering circuit.
- 6-40 **Thermocouple detectors.** This kind of temperature detector is similar to the resistance type in appearance and in its location in the motor. However, instead of a resistance wire, its sensing element is a thermocouple, which produces a small potential difference that increases with rising temperature.
- 6-41 The thermocouple detector can be wired to a remote indicating circuit. However, to avoid extraneous potential differences and incorrect indications, you must use special thermocouple lead wire to connect the detectors into the circuit.

## Current-Sensing Devices

- 6-42 The second kind of device for protection against motor overheating is the current-sensing device. The simplest are fuses and thermal overload relays.
- 6-43 **Fuses.** Line fuses provide basic protection for motors. However, line fuses have a disadvantage in that they act only under conditions of excess current. An increase in winding temperature from a cause other than current can result in the windings overheating without receiving any protection from the fuse.
- 6-44 Motors require much more current for starting than for running. In many cases, the starting-current surge may be three to six times the normal running current. An ordinary line fuse blows very quickly if the current exceeds the rating of the fuse.
- 6-45 You could install a line fuse having a rating high enough to permit the necessary starting current. But such a fuse would give little or no protection against overheating of the windings under normal running-load current conditions. Line fuses are also inadequate as protection for the motor, because they are easily replaceable with a fuse of a higher rating. For example, if the load current becomes high enough to blow the fuse, it is a simple matter to substitute a fuse with a higher rating. However, the motor windings can be damaged if the overload continues.
- 6-46 Thermal time-delay fuses are now widely used. One kind, known as the *dual-element fuse*, has a time delay that holds the current-carrying element while the motor starts. Yet, the fuse provides the same overcurrent protection as an ordinary fuse.
- 6-47 **Thermal overload relays.** Most motor burnouts are caused by currents that exceed the motor's rating. In the thermal OL relay, excessive current raises the temperature of a heater element. The increased temperature actuates the relay, which trips a latch and opens the motor-control circuit to disconnect the motor from the line. A simple diagram of a protected motor circuit is shown in Figure 6.7 on the following page. The schematic diagram shows how the parts function together.
- 6-48 For reliable operation, the overload relay must be located in the same temperature environment as the motor. The safety factor that represents the motor's protection is the difference between the overload trip temperature and the motor insulating rating.
- 6-49 As the ambient temperature rises, less load current is needed to trip the relay. In cool surroundings, the opposite effect occurs —the motor runs cooler and is capable of carrying a higher load current without overheating. At the same time, the overload relay will handle a higher current without tripping. Under these conditions, the maximum load a motor can safely carry closely parallels the maximum current the overload relay will allow it to carry. This is an ideal match for open-type motors operating at the same ambient temperature as the overload relay.

## Current-Sensing Devices (continued)

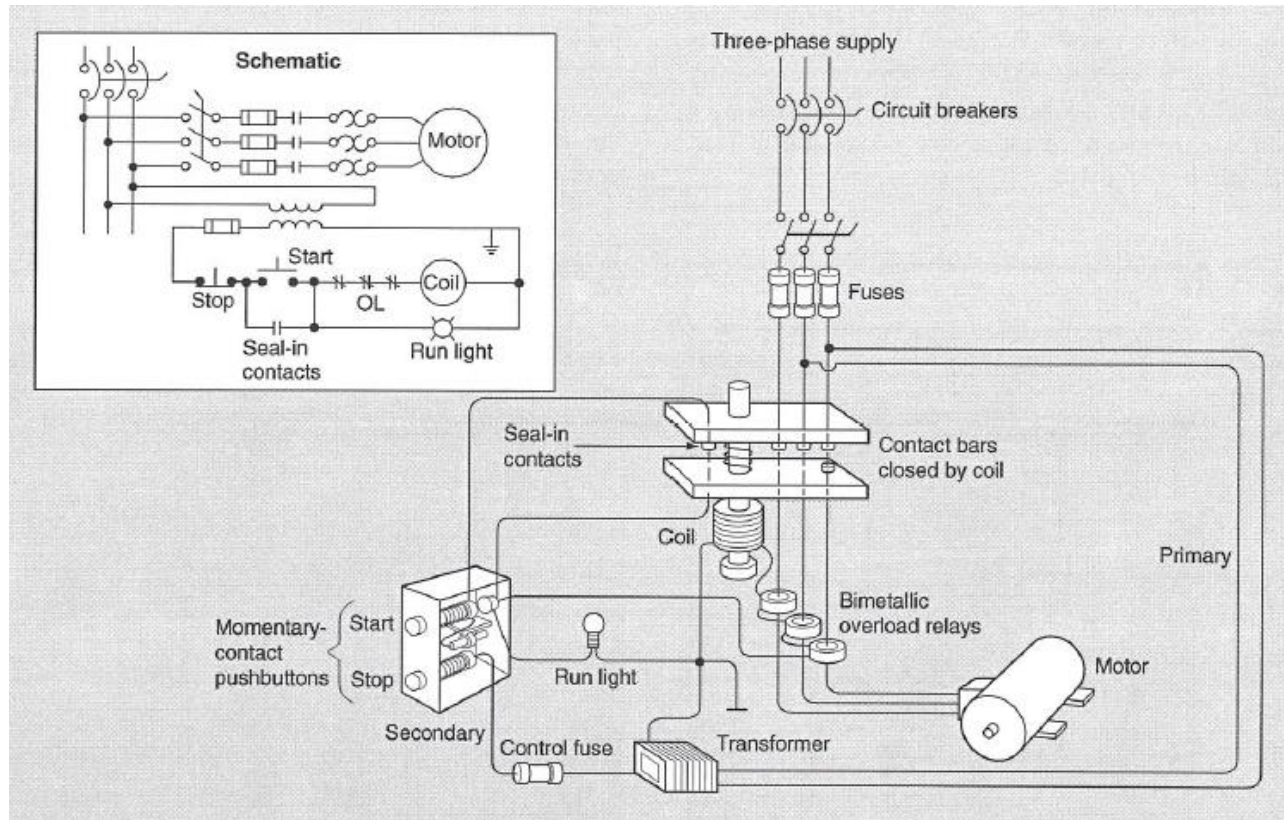

**Figure 6.7: Protected Three-Phase Motor Circuit**

- 6-50 Overload tripping may occur under high ambient-temperature conditions. It is then tempting to conclude that this is a nuisance trip, and to make an effort to prevent the relay from operating. Replacing the correct heater element with a larger one is poor practice. It reduces the motor protection at all temperatures. Trip-free relays are available and should be specified on all motor controls. A *trip-free relay* will trip even if the reset pusher is blocked or held in.
- 6-51 A heater element in the relay is connected in series with the motor circuit. Tripping is accomplished by the relay, which opens the motor-control circuit. The trip point (measured in amperes) is determined by the heater rating. Figure 6.8 on the following page shows an example of a motor starter with three thermal overload relays attached.
- 6-52 Heaters of various current ratings are interchangeable within the specific product lines of any given manufacturer. The appearances of heaters vary greatly from one manufacturer to another, and even among different lines offered by the same manufacturer. However, all heaters translate an increase in motor current to an increase in temperature in the overload relay. An example of a heater is shown in Figure 6.9 on the following page.



## Current-Sensing Devices (continued)



Figure 6.8: Overload relays on a Motor Starter



Figure 6.9: Overload Relay and Heater

## Melting-Alloy Relays

6-53 In a melting-alloy overload relay, the heating element melts a metal alloy inside the relay. The alloy is selected to melt at a precise temperature, usually near  $100^{\circ}\text{C}$  ( $212^{\circ}\text{F}$ ). When the alloy melts, it allows a plunger to rotate, releasing a spring-loaded trip slide as shown in Figure 6.10.

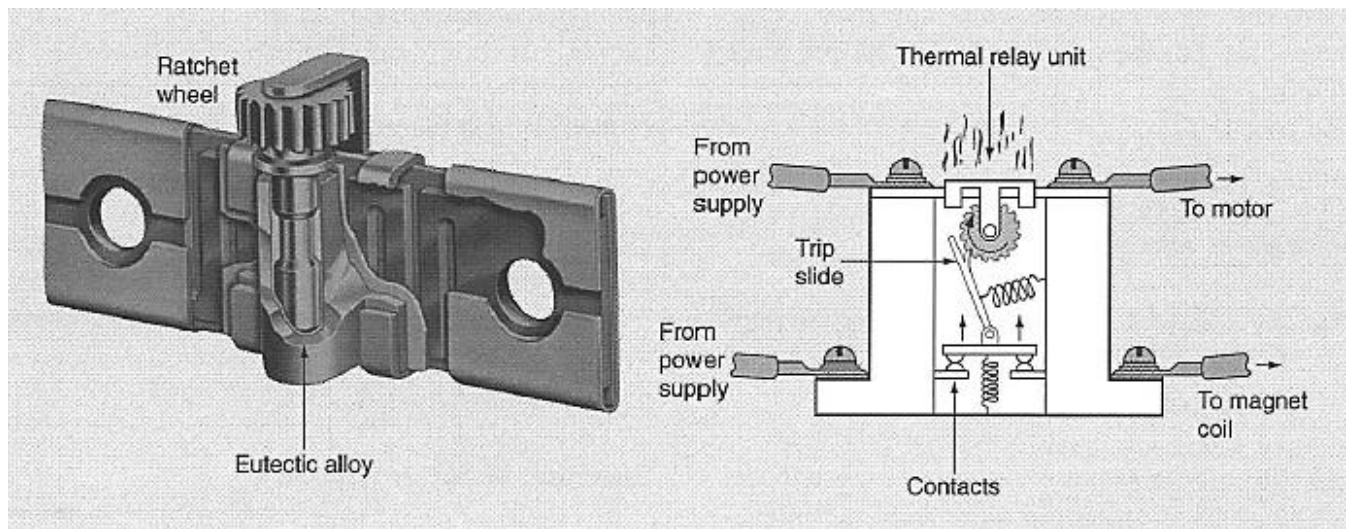

Figure 6.10: Melting-Alloy Relay

## Melting-Alloy Relays (continued)

- 6-54 A *eutectic alloy* melts at a precise temperature, and goes directly from solid to liquid stage. There is no "soft" stage between the liquid and solid stages. The temperature at which the alloy melts is not affected by time or use. When the alloy refreezes after tripping, the plunger can no longer rotate, and you can reset the spring-loaded relay contacts.
- 6-55 Generally, this kind of overload relay has high contact forces and is shock-resistant. Its contacts can withstand high inrush and continuous currents, and the unit is practically waterproof. These relays are considered to be the most reliable of all thermal overload protective devices.
- 6-56 Melting-alloy relays are also called *solder-pot relays*. This name comes from the fact that solder is an alloy (of tin and lead). However, ordinary solder is never used in melting-alloy relays. The melting point of the alloy is fixed by the alloy's composition, and it cannot be adjusted. These relays have trip indicators to provide visible evidence of tripping. Melting-alloy relays require no calibration.

## Bimetallic Relays

6-57 Bimetallic overload relays work on another principle. Figure 6.11 is a diagram of this kind of relay. Heat causes the bimetallic strip to bend, because the two metals expand at different rates. As the heater current increases, the bimetallic strip bends until it actuates a switch.

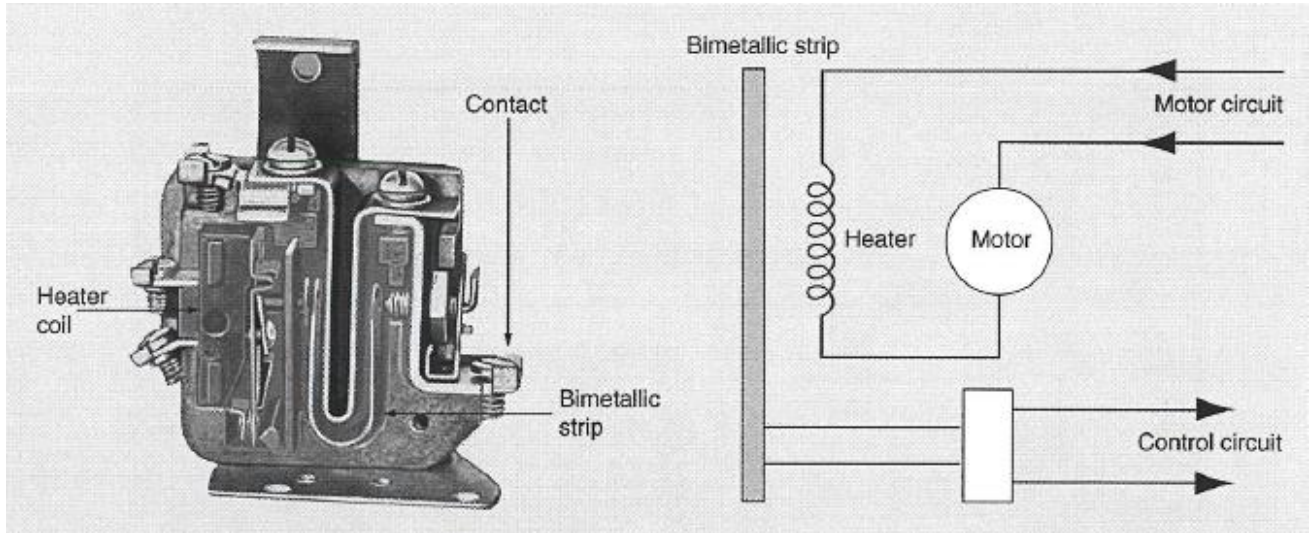

Figure 6.11: Bimetallic relay

- 6-58 Often, bimetallic relays can be adjusted for either automatic or manual reset. The bimetallic strip is able to trip the switch during heating, and is strong enough to trip the switch back again during cooling. Thus, the relay can reset automatically.
- 6-59 Variations in individual bimetallic relays make it necessary for them to be calibrated during manufacture. This is done by means of an adjustment screw that sets the relay to trip at a precise temperature, generally near 200°F (approximately 100°C). After adjustment, the screw is sealed to prevent tampering.
- 6-60 All the overload relays discussed so far have one major limitation. They do not directly sense the motor temperature. Most relays are designed to operate by paralleling the motor temperature, and they do a fairly accurate job under both steady running conditions and widely fluctuating conditions.



## Bimetallic Relays (continued)

6-61 If a motor starts and stops often, however, it may not be completely protected by the bimetallic relay. The graph in Figure 6.12, on the following page, shows why. As the motor is loaded, the relay temperature parallels the motor temperature closely. However, when the motor is off, the relay cools faster than the motor because it has less mass. After operating through several cycles, the temperature of the relay may be much lower than that of the motor. Thus, the motor may become too hot, but the overload relay will not have reached its trip point.

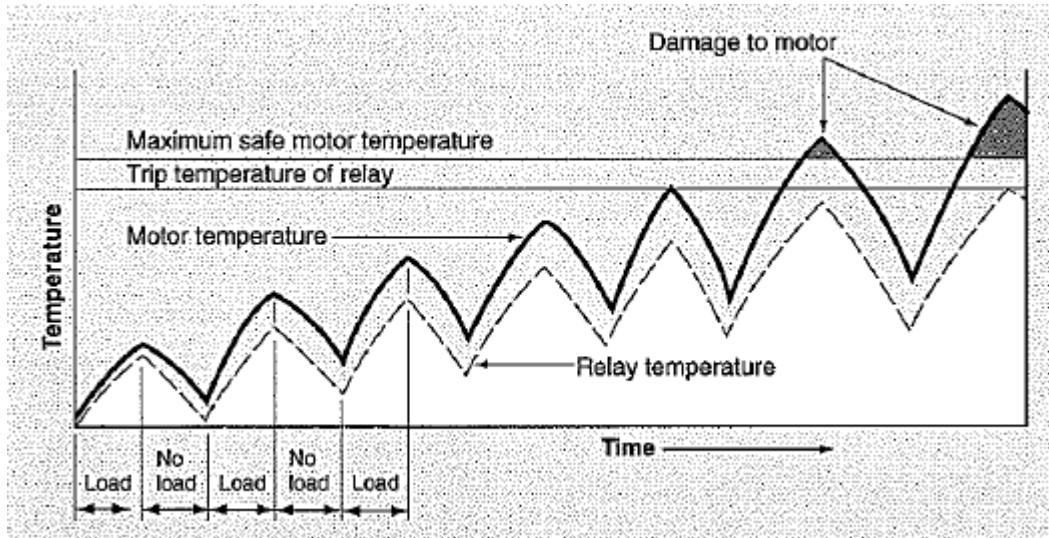

Figure 6.12: Temperatures from Intermittent Load

6-62 The relay and the motor will again operate at corresponding temperatures if the operating cycle changes in one of two ways.

- If the motor remains off for a long-enough time, both the motor and the relay will cool to the surrounding temperature.
- If the motor remains on for a long-enough time, both the motor and the relay will rise to the same temperature.

6-63 The National Electrical Code defines the upper limit on the rating of a motor overload protector. The protective device must trip at no more than 125% of the motor's full-load current rating, depending on the kind of motor.

6-64 In determining how heaters will be rated in their respective lines, manufacturers use different methods for ensuring that NEC requirements are met for all motors. Although the methods of rating heaters differ among manufacturers, the results are the same.

6-65 Overload heaters are rated in current increments of about 10%. About 50 heaters are required to span the range from 0.5 to 50 A. Each heater can be applied over a 10% range of current. The manufacturer supplies heater-selection tables indicating the range for various conditions. The heater's "must-trip" rating (specified in amperes) is 125% of the minimum value of the full-load current range.

## Bimetallic Relays (continued)

6-66 Among the most important factors to be considered in selecting the proper heater are the ambient temperatures at the location of the motor and at the location of the protective device. Heater trip ratings, as well as ratings of today's motors, are based on an ambient temperature of 105°F (40°F).

## Selecting Motor Protection

6-67 Paragraph 430-6(a) of the National Electrical Code states that "Separate motor overload protection shall be based on the motor nameplate current rating." In the same Article (430) of the Code, however, tables give nominal full-load current for motors of various horsepower ratings. In the past, it was a common practice to select overload protection entirely on the basis of current ratings given in these tables. Unfortunately, this practice is still followed in many plants today.

6-68 Good practice calls for a policy of specifying motor protection on the basis of actual motor characteristics. Such a policy means that protection will be selected on the basis of motor nameplate information, rather than on a table that gives nominal characteristics for a broad class of motors.

6-69 Because of differences in basic design, speed, efficiency, and power factor, motors having identical horsepower ratings can have quite different current ratings. A heater selected on the basis of the NEC tables, rather than on the basis of the motor's nameplate rating, can trip the relay at a current that is significantly too high or too low. Using nominal standards to select the heater for a specific motor always involves a certain amount of unnecessary risk.

6-70 Selection of proper overload heaters is essential to providing proper protection. It is because of improper heater selection that most thermal OL relays are used improperly. There are two ways to select the right heater.

- The motor manufacturer provides a list of the approved heaters to be used with the motor under various environmental conditions.
- The heater is selected at the job site, where the nameplate information is read firsthand.

6-71 In addition to the full-load current rating, motor nameplate information is helpful in selecting the proper heater. Paragraph 430-32(a)(I) of the NEC states that motors with a service factor lower than 1.15 must be protected by an overcurrent device rated to trip at not more than 115% of the motor's rated full-load current. A service factor of 1.15 means that the manufacturer guarantees successful operation at 1.15 times the rated full-load current without damage due to heating.

6-72 However, the service factor can be other than 1.15. Motor manufacturers list the value on the motor nameplate. Because OL relay heater elements are rated in 10% increments, it is important to select a heater only one size smaller. This reduction decreases the protection margin from the standard 125% of motor rating to the required 115%.

## Selecting Motor Protection (continued)

- 6-73 Nearly all motors classified by the National Electrical Manufacturers Association (NEMA) as TEFC (totally enclosed, fan cooled) motors, with Class B insulation, have a service factor of 1.0. These motors must be protected according to the 115% standard.
- 6-74 Paragraph 430-32(a)(1) of the NEC also states that motors rated for a temperature rise in excess of 40°C must also be protected at a maximum of 115% of full load rating. For such motors, the next smaller heater must also be selected from the relay manufacturer's heater selection table.
- 6-75 It is good practice to follow the 115% rule any time the service factor cannot be identified as being 1.15 or higher. Use the same rule if you cannot identify the temperature rise as being a maximum of 40°C.

## Ambient-Compensated Overload Relays

- 6-76 Where the ambient temperature at the relay requires a heater rated two sizes larger than the one specified by the manufacturer's tables, you should use an ambient-compensated OL relay. An increase in heater size alters the overall trip characteristics of the relay. If heaters two or more sizes over the basic recommendation are installed, the change in trip characteristics can become significant. Using compensating-type relays eliminates the need for heater de-rating.
- 6-77 Melting-alloy and bimetallic thermal overload relays are not completely reliable when the motor is operating in a constant temperature and the relay is operating in varying temperatures. Ambient temperature affects both kinds of relays, but not the motor. Therefore, it is best to use an overload relay that reacts only to the motor current and not to changes in ambient temperature. Figure 6.13, on the following page, shows the effect of ambient temperature on the ultimate trip current of both compensated and non-compensated relays.

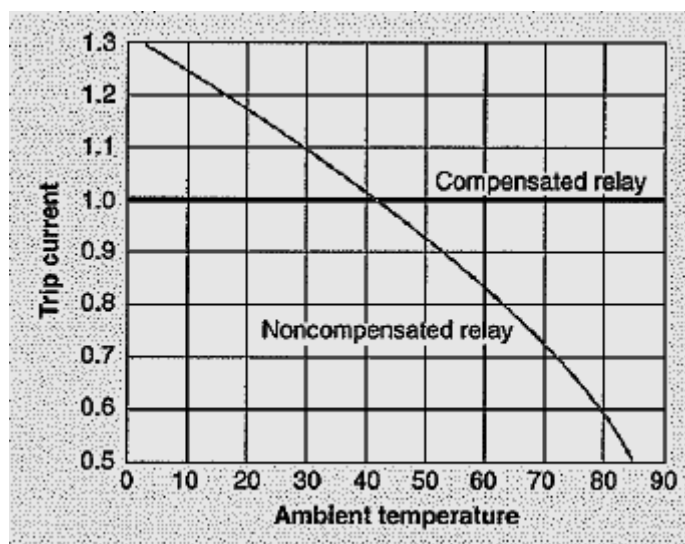

Figure 6.13: Temperatures from Intermittent Load

- 6-78 The diagram in Figure 6.14, on the following page, shows how a compensated relay works. The main bimetallic strip is fixed at one end and receives the heat from the heater above it. The compensating bimetallic strip is riveted to a trip lever. A flat spring acts as a pivot and forces both bimetallic strips to bear against the spacer at points A and B. This force also holds the lever properly against the toggle switch, which is fixed in position.

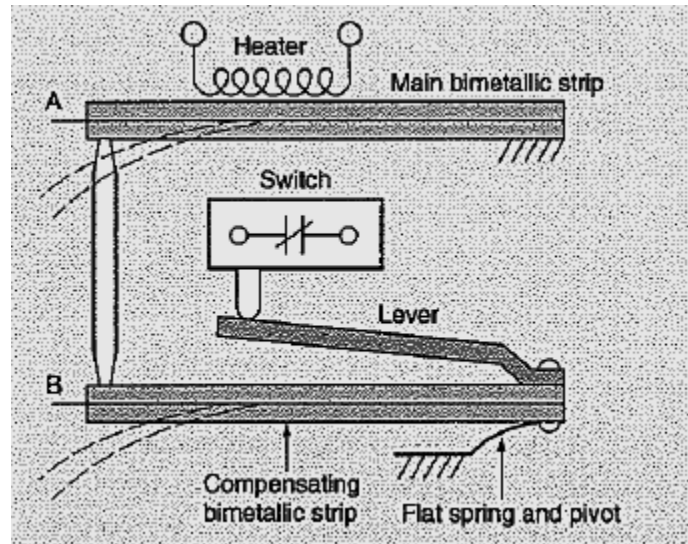

Figure 6.14: Temperature-Compensated Relay

- 6-79 An increase in ambient temperature causes both bimetallic strips to bend downward equally. Thus, the lever does not change position, and the toggle switch does not operate. However, an increase in current in the heater element bends the main bimetallic strip without affecting the compensating strip. The spacer pushes the lower bimetallic strip downward. The lower strip pivots on the flat spring. At this point, the lever operates the toggle switch.
- 6-80 Ambient-compensated bimetallic overload relays are available for either automatic or manual reset. Their tripping currents and times are independent of ambient temperatures within a range of -20 to 170°F (-29 to 77°C). Most of these relays are designed to be trip-free. Like the non-compensated relays, a well-designed compensated relay has contacts that are self-cleaning. They wipe as the bimetallic strips deflect.

## Single Phasing

6-81 It is not unusual for three-phase motors to continue running after one phase has been lost. This condition is commonly called *single phasing*. An open phase in the primary of a Y-delta or delta-Y transformer serving a motor causes approximately twice the rated current to appear in one phase of the motor if the motor continues to run. If the phase carrying the high current lacks overcurrent protection, as shown in Fig. 6-15, the single-phasing motor can be seriously damaged.

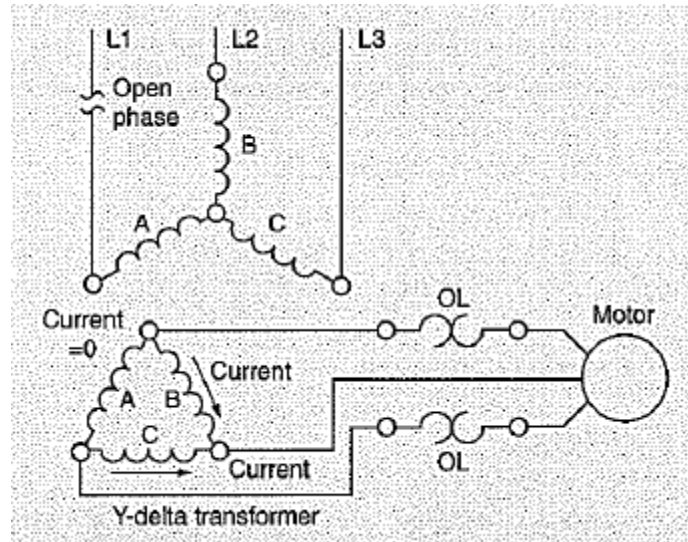

Figure 6.15: Unprotected Phase in a Motor

6-82 It was previously thought that protection in only two phases was adequate, because it is unlikely that all factors leading to this unprotected condition will be present. However, Table 430-37 of the National Electrical Code requires OL protection in all three phases of a three-phase system. Manufacturers now include protection in the third phase.

## Protecting Overload Relays

- 6-83 No discussion of the application of thermal overload relays for motor protection is complete without considering protection for the relay itself. Overload relays and their heater elements are designed to withstand current somewhat in excess of the locked rotor currents of the motors they are intended to protect. However, if fault currents exceeding 13 times the motor's full-load current rating occur, and proper motor branch circuit protection has not been provided, the heater will be damaged.
- 6-84 Fault currents exceeding 100 times a motor's full-load current rating are not unusual. If such a condition occurs, the heater can act as a fuse. With the heater not conducting—and therefore not heating—the relay itself, as well as the motor it is intended to protect, can be seriously damaged.
- 6-85 Table 430-7(b) in the NEC defines letter codes based on the electrical power (measured in kilovolt-amperes) drawn by a motor, per horsepower of rated mechanical power, when the rotor is locked. The maximum size of a motor branch circuit protector is then defined in Table 430-52, as a multiple of the motor's full-load current based on these code letters.
- 6-86 The maximum allowed rating of any protective device depends on the particular kind of device it is. For example, the allowed rating of an instantaneous-trip circuit breaker is generally four to five times the rating allowed for a dual-element fuse. The branch-circuit protector must be capable of operating at a current greater than the locked-rotor current and less than 13 times the motor's full-load current.
- 6-87 The wide use of thermal overload relays indicates their acceptance as the most practical means of providing overload protection for motors. Proper heater selection is the key to proper application of thermal overload relays. Therefore, you must pay careful attention to the factors that affect heater performance. Most significant among these factors are the following:
- full-load current
  - temperature-rise rating
  - service factor
  - ambient temperature, at the motor and at the protector
  - locked-rotor current ratio
  - starting time
  - duty cycle
  - locked-rotor endurance time.

If these factors are not considered, the result is poor relay performance.

## Chapter 6 Exercise

Circle the appropriate letter next to the correct answer.

1. A circle that supplies a number of outlets for lighting and appliances is called a(n) \_\_\_\_\_.
  - a. General-purpose branch
  - b. Individual branch
  - c. Multi-wire branch
  - d. Three-phase, four-wire
  
2. An example of motor branch-circuit overcurrent protection is a(n) \_\_\_\_\_.
  - a. Circuit breaker
  - b. Feeder
  - c. Overload relay
  - d. Temperature detector
  
3. A thermostatic detector consists of a \_\_\_\_\_.
  - a. Loop of resistance wire
  - b. Relay
  - c. Sealed bimetallic thermostat
  - d. Thermocouple
  
4. What kind of temperature detector should be used if you need to know the actual temperature of the winding at any time?
  - a. Resistance
  - b. Thermocouple
  - c. Thermometer
  - d. Thermostatic
  
5. A dual-element fuse \_\_\_\_\_.
  - a. Allows a temporary overcurrent
  - b. Can blow twice
  - c. Can carry double current
  - d. Can protect two motors

## Chapter 6 Exercise (continued)

Circle the appropriate letter next to the correct answer.

6. A trip-free relay trips \_\_\_\_\_.
- a. At high ambient temperature
  - b. At low ambient temperatures
  - c. Even if the reset pusher is held in
  - d. Only rarely
7. Which of the following is considered the most reliable of all thermal overload protective devices?
- a. Ambient-compensated relay
  - b. Bimetallic relay
  - c. Melting-alloy relay
  - d. Trip-free relay
8. A motor overload protector must trip at not more than \_\_\_\_\_% of the motor's full-load current rating.
- a. 100
  - b. 125
  - c. 150
  - d. 175
9. Motors with service factor of less than 1.15 must be protected by an overcurrent device rated to trip at no more than \_\_\_\_\_% of the motor's rated full-load current.
- a. 100
  - b. 115
  - c. 125
  - d. 145
10. What kind of overload relay should you use if the ambient temperature requires a heater rated two sizes larger than the one specified by the manufacturer?
- a. Ambient compensated
  - b. Bimetallic
  - c. Melting alloy
  - d. Trip free



## Summary

The use of protective devices is necessary to prevent motor damage and costly downtime. The electrical maintenance worker must know how to select the proper device for the application.

Fuses protect the motor feeder. If only one motor is connected to the feeder, the protective device is of the same rating as the branch-circuit protective device. If more than one motor is connected, you must use Table 430-52 if the NEC to find the current rating required for the feeder. Motor branch-circuit overcurrent protection is provided by a circuit breaker or by a fuse. By using the same table and the motor's full-load current, you can determine the maximum allowable fuse rating.

An overload relay is usually used to provide motor- running overcurrent protection. The information needed to select a relay is found on the nameplate and on the inside of the motor-starter enclosure. Inherent thermal protection is provided by temperature detectors built into the motor windings. Detectors can trigger an alarm or take the motor off line if the temperature rises too high.

Overheating caused by excessive current is a common cause of motor trouble. Motor protection can be provided either by a temperature-monitoring protector or by a current-sensing device. The most effective is the temperature-monitoring protector, a sealed bimetallic thermostat that actually monitors the motor temperature. Current-sensing devices, including fuses, circuit breakers, relays, and other remote control equipment, protect the power system rather than the motor itself. Melting-alloy relays, bimetallic relays, and ambient-compensated relays are types of overload relays commonly used as current-sensing devices.

Most thermal overload relays have a heater. Proper heater selection is essential to relay operation. In choosing a heater, you must consider the factors that affect heater performance. These include the motor's full-load current, temperature-rise rating, service factor, ambient temperature, locked-rotor current ratio, starting time, duty cycle, and the locked-rotor endurance time.



## Answers to Chapter 1 Exercise

1. b. Green (Paragraph 1-6)
2. d. Resistance of the conductor (Paragraph 1-8)
3. c. 75 (Paragraph 1-16)
4. b. Greater resistance when wet (Paragraph 1-24)
5. a. Gas (Paragraph 1-26)
6. d. Is familiar with equipment operation and hazards (Paragraph 1-30)
7. a. Cotton (Paragraph 1-31)
8. a. Replaced (Paragraph 1-35)
9. c. A Class C extinguisher (Paragraph 1-36)
10. c. Lock out the power (Paragraph 1-37)

## Answers to Chapter 2 Exercise

1. d. Two lines meet (Paragraph 2-4)
2. b. 60° (Paragraph 2-9)
3. b. Right triangle (Paragraph 2-10)
4. b. Horizontal; toward the right (Paragraph 2-19)
5. b. Impedance (Paragraph 2-20)
6. d. Right (Paragraph 2-32)
7. d. Leads (Paragraph 2-39)
8. c. Phase angle (Paragraph 2-54)
9. b. Peak value (Paragraph 2-56)
10. a. Divided by 0.707 (Paragraph 2-57)

## Answers to Chapter 3 Exercise

1. d. Resistance (Paragraph 3-2)
2. b. Length of the coil increases (Paragraph 3-18)
3. a. AC circuit (Paragraph 3-25)
4. c. Radian (Paragraph 3-32)
5. d. 377 (Paragraph 3-33)
6. b. Delays the rise and fall of current (Paragraph 3-39)
7. d. Resistance (Paragraph 3-53)
8. b. Add vectors (Paragraph 3-58)
9. d. Sum of all values (Paragraph 3-68)
10. a. Decreases it (Paragraph 3-74)

## Answers to Chapter 4 Exercise

- d. Retains (Paragraph 4-4)
- b. DC (Paragraph 4-8)
- a. Ambient temperature (Paragraph 4-14)
- a. Air (Paragraph 4-26)
- b. Across the AC line (Paragraph 4-35)
- b. 500 (Paragraph 4-37)
- c. Resistor (Paragraph 4-40)
- d. Lower than the lowest capacitance (Paragraph 4-43)
- d. Size of the plates (Paragraph 4-48)
- c. Frequency and capacitance (Paragraph 4-62)

## Answers to Chapter 5 Exercise

- c. Resistors (Paragraph 5-1)
- c.  $X_L$  (Paragraph 5-2)
- d. Vector sum of the two reactances (Paragraph 5-3, 5-4)
- a. 2000  $\Omega$  (Paragraph 5-7)
- c. Lags (Paragraph 5-12)
- d. Total reactance (Paragraph 5-15)
- c.  $X_L$  and  $X_C$  are equal (Paragraph 5-21)
- b. Current (Paragraph 5-28)
- b. Horizontally (Paragraph 5-32)
- a. Capacitor (Paragraph 5-37)

## Answers to Chapter 6 Exercise

- d. 3600 lb-ft (Paragraph 6-2)
- b. Power (Paragraph 6-14)
- a. Negative power value (Paragraph 6-22)
- d. Reactance (Paragraph 6-24)
- d. Resistor (Paragraph 6-36)
- b. Phase angle will decrease (Paragraph 6-46)
- a. Add capacitors to the circuits (Paragraph 6-51)
- a. Across any two lines (Paragraph 6-65)
- c. Proper installation (Paragraph 6-67)
- c. 165 to 250 (Paragraph 6-71)